

Technical Instructions

Description ■

Powers' HydroGuard® XP Series SH1430 & LFSH1430 Hi/Lo systems are fully assembled factory tested systems, designed to provide safe water throughout commercial and institutional facilities. HydroGuard® XP Series SH1430 & LFSH1430 Hi/Lo systems consist of MM434 or LFMM430 and Series SH1430 or LFSH1430 thermostatic valves which utilize paraffin-based actuation technology to sense and adjust outlet temperature.

Each system includes ball valves, pressure/temperature gauges and Powers' triple-duty checkstops. Hi/Lo systems also include a PRV. Optional equipment include cabinets and/or Powers' AquaSentry® 2 high-temperature alarm system. (Not available with LFSH1430 Series).

Operation ■

Two-valve supply fixtures feature a low capacity valve that works in parallel with a high capacity valve. During low demand, the low capacity valve handles the load requirements. As the load demand is increased, the pressure reducing valve, which is set at a certain pressure differential, will open and allow flow through the high capacity valve to assist the low capacity valve in meeting the increased load requirements.

Specifications ■

Maximum Operating Pressure	125psi (861 kPa)
Maximum Hot Water Temperature	200°F (93°C)
Minimum Hot Water Supply Temp.*	5°F (3°C) Above Set Point
Hot Water Inlet Temperature Range	120 - 180°F (49 - 82°C)
Cold Water Inlet Temperature Range	40 - 80°F (4 - 27°C)
Minimum Flow**	0.5 gpm (1.89 lpm)
Temperature Adjustment Range ***	90 - 160°F (32 - 71°C)
Listing/Compliance (Valve only).....	ASSE 1017, CSA B125

* With Equal Pressure

** Minimum flow when Hi/Lo valve is installed at or near hot water source recirculating tempered water with a properly sized continuously operating recirculating pump.

*** Note: Low limit cannot be less than the cold water temperature. For best operation, hot water should be at least 5°F (3°C) above desired set point.

Capacity ■

Flow Capacity at 50-50 Mixed Ratio								
		Pressure Drop Across Valve						
Model	Min. Flow to ASSE 1017	C _v	5psi (34 kPa)	10psi (69 kPa)	20psi (138 kPa)	30psi (207 kPa)	45psi (310 kPa)	60psi (414 kPa)
SH1432DV and LFSH1432DV	2 gpm 8 lpm	27.4	61 gpm 231 lpm	87 gpm 329 lpm	123 gpm 466 lpm	150 gpm 568 lpm	184 gpm 697 lpm	213 gpm 806 lpm
SH1432HL and LFSH1432HL	1 gpm 4 lpm	30.0	67 gpm 254 lpm	95 gpm 360 lpm	134 gpm 507 lpm	164 gpm 621 lpm	201 gpm 761 lpm	232 gpm 878 lpm
SH1434DV and LFSH1434DV	2 gpm 8 lpm	37.4	84 gpm 318 lpm	118 gpm 447 lpm	167 gpm 632 lpm	205 gpm 776 lpm	251 gpm 950 lpm	290 gpm 1098 lpm
SH1434HL and LFSH1434HL	1 gpm 4 lpm	40.4	90 gpm 341 lpm	128 gpm 485 lpm	181 gpm 685 lpm	221 gpm 837 lpm	271 gpm 1026 lpm	313 gpm 1185 lpm

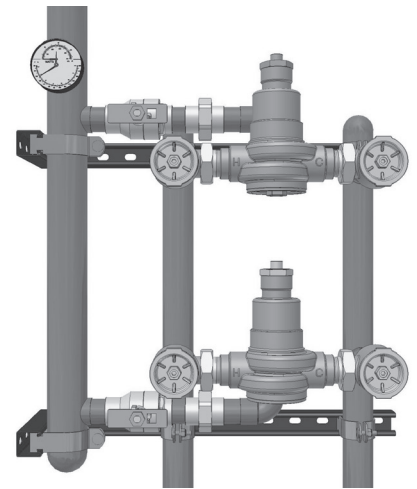

Advanced Thermal Activation



WARNING: TO ENSURE THE ACCURATE AND RELIABLE OPERATION OF THIS PRODUCT, IT IS ESSENTIAL TO:

- Properly size each valve based on the individual application.
- Properly design the recirculation system to minimize pressure and temperature variations.
- Conduct an annual maintenance program to ensure proper operation of all critical components.

THIS VALVE MUST BE USED IN CONJUNCTION WITH TEMPERATURE ACTUATED POINT-OF-USE DEVICES THAT COMPLY WITH ASSE 1016, 1069, OR 1070. FAILURE TO COMPLY WITH PROPER INSTALLATION INSTRUCTIONS COULD CONTRIBUTE TO VALVE FAILURE, RESULTING IN INJURY OR DEATH.

Installation Instructions ■

Prior to Installation

1. Flush all piping thoroughly before installing.
2. Make sure all ball valve handles are in "OFF" position.
3. In order to make any temperature adjustment to the valves, you must open end-of-line fixtures to ensure you have adequate flow across the valve.
4. Use a thermometer at the showerhead or install an in-line thermometer at the point-of-use.

Set Up Procedure ■

You must follow these procedures in order to properly adjust your Hi/Lo System. You need flow greater than the minimum shown in capacity table across the valve in order to set a maximum temperature.

1. Close the low flow valve on the outlet of the low flow valve.
2. Open the ball valve at the discharge of the high flow valve.
3. Open enough fixtures to meet the minimum flow requirement as per capacity table.
4. Set valve temperature. Refer to IS-P-MM430 & IS-P-SH1430.
5. For "DV" skip to #6. For "HL" set the PRV as follows for a 15psi differential.
 - a) Loosen the locknut at the top of the PRV. This must be all the way out or you will be limiting the range of the adjustment.
 - b) Adjust the PRV so the outlet pressure gauge reads 15psi less than the supply pressure gauge. Turning the adjustment screw counterclockwise will increase the differential across the PRV (allowing the PRV to open later).
6. Close the ball valve at the discharge of the high flow valve and open the low flow side ball valve by rotating the handle fully counterclockwise.
7. Open enough fixtures to meet the minimum flow requirement as per capacity table.
8. Set the temperature for the low flow valve. Refer to IS-P-MM430 & IS-P-SH1430.
9. Open the ball valve at the discharge of high flow valve.

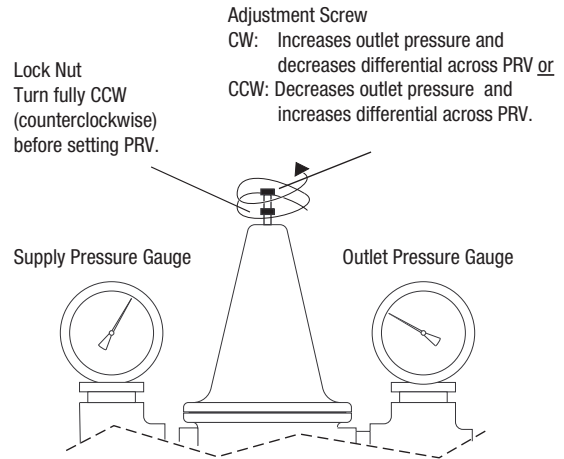

10. Open additional fixtures to create a 20psi differential between supply and outlet pressure gauge.
11. When water is at desired outlet temperature, verify temperature remains at set point.
12. Gradually start to close fixtures to verify that the temperature remains constant through the full range of flow.
13. For any problem, refer to Troubleshooting section of the document or contact Powers' Technical Support Department at 1.800.669.5430 or info@powerscontrols.com.

Adjusting Individual High Flow and Low Flow Valves ■

See enclosed IS-P-MM430 and IS-P-SH1430.

Troubleshooting ■

What to look for if:

• Outlet temperature is too hot with low flow:

1. The maximum temperature of the low flow valve was not properly set. Refer to Setup Procedure and reset the maximum temperature of the low flow valve.
2. The thermal actuator of the low flow valve is not working properly. Replace accordingly to the appropriate technical instructions (IS-P-SH1430 enclosed).

• Outlet temperature is too hot with a high flow:

1. The maximum temperature of a high flow valve was not properly set. Refer to Setup Procedure and reset the maximum temperature of the high flow valve.
2. The thermal actuator of the high flow valve is not working properly. Replace accordingly, IS-P-MM430 enclosed.

• Outlet temperature too low on low and high flow:

1. The hot water temperature is too low. You must have a supply temperature of at least 5°F (3°C) higher than the set temperature. Re-adjust the hot water supply.
2. The checkstops on the hot side of the valve are not fully open, or may be stuck due to liming. Open and clean checkstops.
3. The temperature has not been set properly on the small and/or large valve. Refer to the Setup Procedure and reset the valves.

• Outlet flow drops off:

1. The differential across the PRV is set too high, so the high flow valve begins controlling the system too late and starves the system. Refer to the Setup Procedure and decrease the differential across PRV.
2. The checkstops on the high flow valves are not fully open or are stuck due to liming. Open and clean checkstops.
3. The system pressure varies by more than 50% of the inlet supply pressure.

• Outlet temperature cycles between hot and cold:

1. The differential across the PRV is set too low, so the high flow valve begins controlling the system too early, and therefore cycles (hunt for the set point). Refer to the Setup Procedure and increase the differential across PRV.
2. The system pressure varies by more than 50% of the inlet supply pressure.

Preventative Maintenance ■

Thermostatic water mixing valves are control devices which must be cleaned and maintained on a regular basis.

1. Before servicing checkstops or piping, turn off the water upstream. At least every twelve (12) months open up the checkstops and check for the free movement of the poppet.
2. Before servicing the valve, turn off the water supply upstream or close the checkstops. To close the checkstops, turn the adjusting screw clockwise.
3. When opening checkstops after servicing, turn adjusting screw counterclockwise to fully open position then turn adjusting screw 1/2 turn clockwise for final setting.
4. Every three (3) months, check the maximum temperature adjustments.
5. Every twelve (12) months, remove the valve bonnets and check the internal components for freedom of movement.

CAUTION:

Any changes in supply condition could effect the outlet water temperature. Check and adjust the valves accordingly to prevent injury to the users.

Parts Kits ■

See enclosed IS-P-MM430 and IS-P-SH1430.

CALIFORNIA PROPOSITION 65 WARNING

WARNING: This product contains chemicals known to the State of California to cause cancer and birth defects or other reproductive harm. (California law requires this warning to be given to customers in the State of California.)

For more information: www.watts.com/prop65



NOTE: AFTER COMPLETING REPAIRS, CHECK DISCHARGE TEMPERATURE. RESET IF NECESSARY.

WARNING: FAILURE TO PERFORM THIS OPERATION COULD RESULT IN UNSAFE DISCHARGE TEMPERATURE, WHICH MAY CAUSE INJURY OR DEATH.

Warranty ■

The Seller warrants that the equipment manufactured by it and covered by this order or contract is free from defects in material and workmanship and, without charge, equipment found to be defective in material or workmanship will be repaired, or at Seller's option replaced F.O.B. original point of shipment, if written notice of failure is received by Seller within one (1) year after date of shipment (unless specifically noted elsewhere), provided said equipment has been properly installed, operated in accordance with the Seller's instructions, and provided such defects are not due to abuse or decomposition by chemical or galvanic action. THIS EXPRESS WARRANTY IS IN LIEU OF AND EXCLUDES ALL OTHER WARRANTIES, GUARANTEES, OR REPRESENTATIONS, EXPRESS OR IMPLIED. THERE ARE NO IMPLIED WARRANTIES OF MERCHANTABILITY OR OF FITNESS FOR A PARTICULAR PURPOSE. The Seller assumes no responsibility for repairs made on the Seller's equipment unless done by the Seller's authorized personnel, or by written authority from the Seller. The Seller makes no guarantee with respect to material not manufactured by it.

POWERS™

A Watts Water Technologies Company



USA: Phone: 1.800.669.5430 • Fax 1.847.229.0526 • www.powerscontrols.com

Canada: Phone: 1.888.208.8927 • Fax 1.888.479.2887 • www.powerscontrols.ca