

Standard Materials

Body & Cover: Ductile Iron ASTM A536
 Coating: NSF Listed Fusion Bonded Epoxy Lined and Coated
 Trim: 316 Stainless Steel
 Elastomers: Buna-N (standard)
 EPDM
 Viton
 Stem, Nut & Spring: Stainless Steel

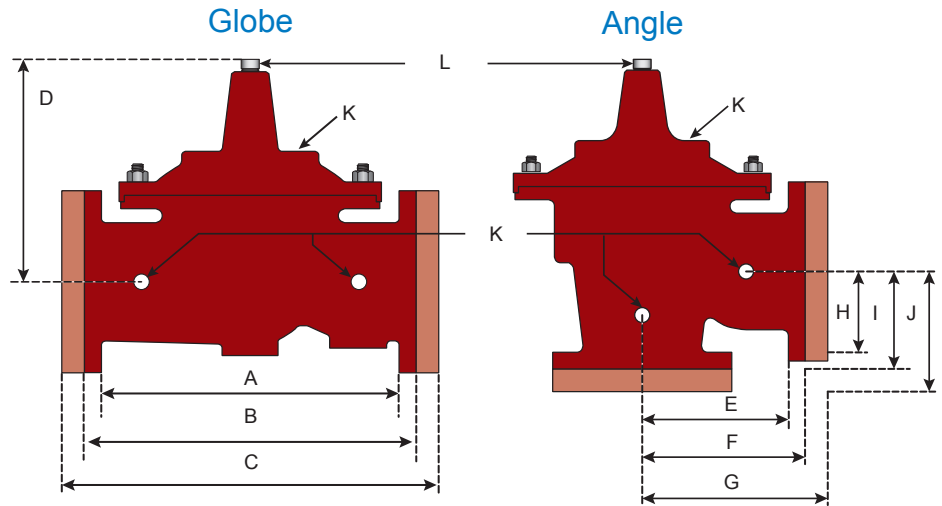

Dimensions

	A	B	C	D	E	F	G	H	I	J	K	L	
VALVE SIZE	GLOBE THRD.	GLOBE 150#	GLOBE 300#	COVER TO CENTER	ANGLE THRD.	ANGLE 150#	ANGLE 300#	ANGLE THRD.	ANGLE 150#	ANGLE 300#	PORT SIZE	PORT SIZE	SHIPPING WEIGHTS*
1-1/4	7-1/4			5-1/2	3-1/4			1-7/8			3/8	1/4	20
1-1/2	7-1/4	8-1/2	9	5-1/2	3-1/4	4	4-1/4	1-7/8	4	4-1/4	3/8	1/4	25
2	9-3/8	9-3/8	10	6-1/2	4-3/4	4-3/4	5	3-1/4	3-1/4	3-1/2	3/8	1/2	40
2-1/2	11	11	11-5/8	7-1/2	5-1/2	5-1/2	5-7/8	4	4	4-5/16	1/2	1/2	65
3	12-1/2	12	13-1/4	8-1/4	6-1/4	6	6-3/8	4-1/2	4	4-3/8	1/2	1/2	95
4		15	15-5/8	10-5/8		7-1/2	7-7/8		5	5-5/16	3/4	3/4	190
6		20	21	13-3/8		10	10-1/2		6	6-1/2	3/4	3/4	320
8		25-3/8	26-3/8	16		12-3/4	13-1/4		8	8-1/2	1	1	650
10		29-3/4	31-1/8	17-1/8		14-7/8	15-9/16		8-5/8	9-5/16	1	1	940
12		34	35-1/2	20-7/8		17	17-3/4		13-3/4	14-1/2	1	1-1/4	1500
14		39	40-1/2	24-1/4		19-1/2	20-1/4		14-7/8	15-5/8	1	1-1/2	1675
16		41-3/8	43-1/2	25		20-13/16	21-5/8		15-11/16	16-1/2	1	2	3100

*Estimated in lbs.

Description

The AMES Models 905GD and 905AD are full port, single chamber basic valves that incorporate a one-piece disc and diaphragm assembly. This assembly is the only moving part within the valve allowing it to open, close, or modulate as commanded by the pilot control system.

Model 905GD: Globe Pattern Single Chamber Basic Valve

Model 905AD: Angle Pattern Single Chamber Basic Valve

Operating Pressure

Threaded = 400 psi / 150 Flanged = 250 psi / 300 Flanged = 400 psi

Operating Temperature

Buna-N: 160°F Maximum

EPDM: 300°F Maximum

Viton: 250°F Maximum

Flow Data - 905GD (Globe) / 905AD (Angle)

Valve Size - Inches	1-1/4	1-1/2	2	2-1/2	3	4	6	8	10	12	14	16
Maximum Continuous Flow Rate Gpm (Water)	95	130	210	300	485	800	1850	3100	5000	7000	8500	11100
Maximum Intermittent Flow Rate Gpm (Water)	119	161	265	390	590	1000	2300	4000	6250	8900	10800	14100
CV Factor GPM (Globe)	25	30	45	75	100	175	490	770	1200	1750	2125	2890
CV Factor GPM (Angle)	26	27	57	91	125	215	571	990	1530	2525	2885	3575

Estimated

Maximum continuous flow based on velocity of 20 ft. per second.

Maximum intermittent flow based on velocity of 25 ft. per second.

The C_v Factor of a valve is the flow rate in US GPM at 60° F that will cause a 1 psi drop in pressure.

The factors stated are based upon a fully open valve.

Cv factor can be used in the following equations to determine Flow (Q) and Pressure Drop (Δ P):

$$Q (\text{Flow}) = C_v \sqrt{\Delta P} \quad \Delta P (\text{Pressure Drop}) = (Q/C_v)^2$$

Headloss

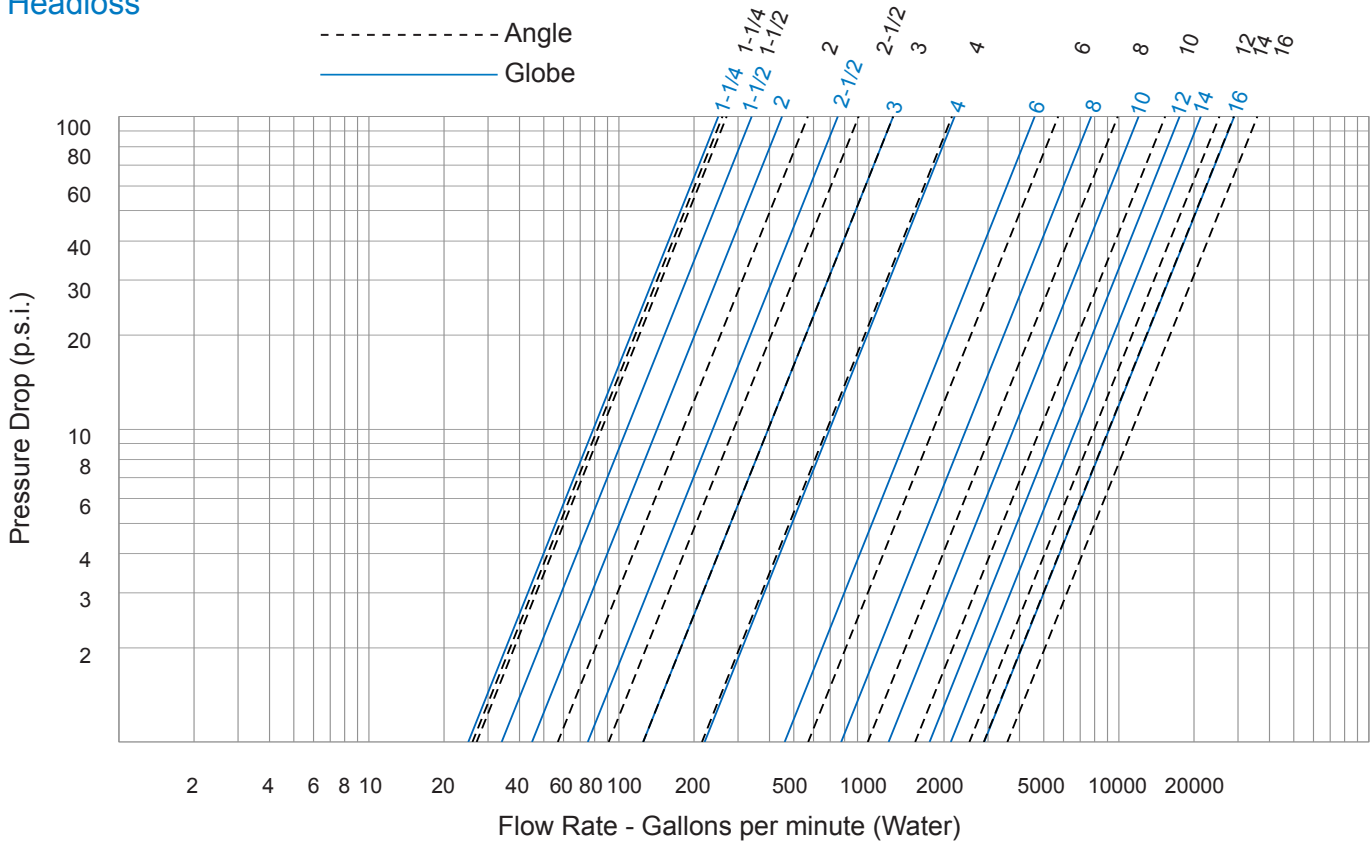

Valve Cover Chamber Capacity

Valve Size (in)	1-1/4	1-1/2	2	2-1/2	3	4	6	8	10	12	14	16
fl.oz.	4	4	4	10	10	22	70					
U.S. Gal								1-1/4	2-1/2	4	6-1/2	9-1/2

Valve Travel

Valve Size (in)	1-1/4	1-1/2	2	2-1/2	3	4	6	8	10	12	14	16
Travel (in)	3/8	3/8	1/2	5/8	3/4	1	1-1/2	2	2-1/2	3	3-1/2	4