



# Series 1000DCV

## Single Detector Check Valves

Sizes: 1 1/2" – 2" (40 – 50mm)

### Features

- Horizontal or vertical installation
- Replaceable bronze seats
- Cast iron body and cover
- Valve is shipped fully assembled with optional bypass line including shutoff valve, meter and single check valve
- Low head loss



### Models

- FLG – Flanged end connections
- THD – Threaded end connections
- CFM – cubic feet per minute meter
- GPM – gallons per minute meter

Series 1000DCV Single Detector Check Valves detect any leakage or unauthorized use of water from fire or automatic sprinkler systems. The valve also prevents the reverse flow of non-potable water from entering into the public mainline.

### Pressure – Temperature

Maximum Working Pressure: 175psi (12 bars)  
 Temperature Range: 33°F – 110°F (5°C – 43°C)  
 Hydrostatic Test Range: 350psi (24 bars)

### Specifications

A Detector Check Valve shall be installed where indicated on the plans to detect any leakage or unauthorized use of water from fire or automatic sprinkler lines. The valve shall also prevent the reverse flow of non-potable water from entering the public mainline. Valve shall have a cast iron body and cover and replaceable bronze seats. The valves shall be an Ames Company Series 1000DCV.

### Materials

Body: Cast iron  
 Cover: Cast iron  
 Seats: Replaceable bronze

---

Job Name \_\_\_\_\_ Contractor \_\_\_\_\_

Job Location \_\_\_\_\_ Approval \_\_\_\_\_

Engineer \_\_\_\_\_ Contractor's P.O. No. \_\_\_\_\_

Approval \_\_\_\_\_ Representative \_\_\_\_\_

Ames product specifications in U.S. customary units and metric are approximate and are provided for reference only. For precise measurements, please contact Ames Technical Service. Ames reserves the right to change or modify product design, construction, specifications, or materials without prior notice and without incurring any obligation to make such changes and modifications on Ames products previously or subsequently sold.

# Dimensions – Weights

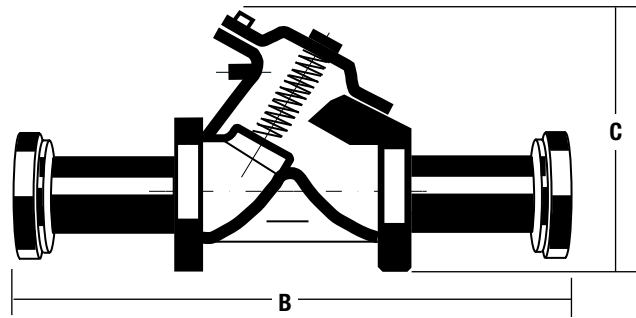
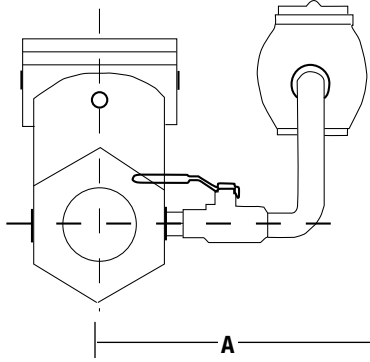

Size	Dimensions								With bypass Weight		Less bypass Weight		
	in.	mm	A		B (threaded)		B (flanged)		C		lbs.	kg	lbs.
1½	40	10	254	17	432	17	432	7½	191	43	19.5	30	13.6
2	50	10	254	17	432	17	432	7½	191	43	19.5	30	13.6

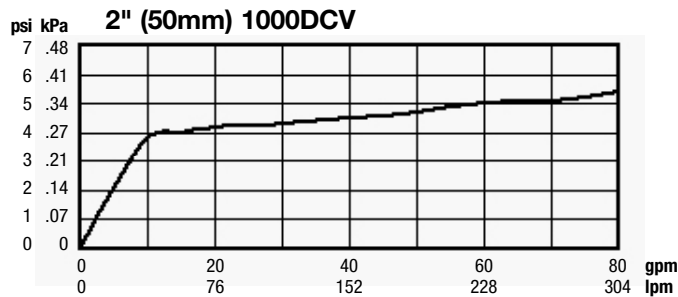
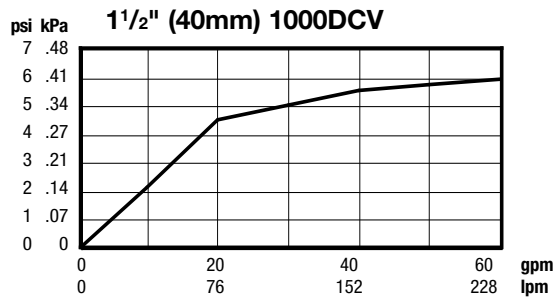

**IMPORTANT: Inquire with governing authorities for local installation requirements.**



www.amesfirewater.com



**ISO 9001-2008 CERTIFIED**

A Watts Water Technologies Company

USA: **Backflow-** Sacramento, CA • Tel: (916) 928-0123 • Fax: (916) 928-9333  
**Control Valves-** Houston, TX • Tel: (713) 943-0688 • Fax: (713) 944-9445  
**Canada:** Burlington, ON • Tel: (905) 332-4090 • Fax: (905) 332-7068

ES-A-1000DCV-S 0314

© 2011 Ames Fire & Waterworks