



# Series 200B

## Double Check Valve Assemblies

Sizes: 1/2" – 2" (15 – 50mm)



### Features

- Cast bronze construction
- Separate access, top entry check valve design
- Reversible seat disc rubber, extends check valve life
- Chloramine resistant elastomers
- Replaceable seats and seat discs
- Compact design
- Top mounted screwdriver slotted ball valve test cocks
- Low pressure drop
- 1/2" – 1" (15 – 25mm) have Tee handles
- No special tools required for servicing
- Plastic on plastic check guiding reduces potential binding due to mineral deposits

Series 200B Double Check Valve Assemblies are designed to protect drinking water supplies from dangerous cross-connections in accordance with national plumbing codes and water authority requirements.

This series may be used in only those cross-connections identified by local inspection authorities as non-health hazard applications. Check with the local authority having jurisdiction regarding vertical orientation, frequency of testing or other installation requirements. Series 200B meets the requirements of ASSE Std. 1015 and AWWA Std. C510.

### Specifications

Double Check Valve Assembly shall be installed at each noted location. Provide assembly with integral shutoff valves that conform to ASSE 1015 and AWWA C510. The assembly shall have top entry access points for each check assembly, screw driver slotted test cocks and require the use of no special tools for servicing. All wetted rubber parts shall be manufactured from silicone or chloramine resistant EPDM rubber. All valve seats and seat discs shall be replaceable. Seat discs shall be reversible to extend check valve life. Check valve guiding shall be plastic to plastic. The assembly shall be an Ames Company Series 200B.

---

Job Name \_\_\_\_\_ Contractor \_\_\_\_\_

Job Location \_\_\_\_\_ Approval \_\_\_\_\_

Engineer \_\_\_\_\_ Contractor's P.O. No. \_\_\_\_\_

Approval \_\_\_\_\_ Representative \_\_\_\_\_

Ames product specifications in U.S. customary units and metric are approximate and are provided for reference only. For precise measurements, please contact Ames Technical Service. Ames reserves the right to change or modify product design, construction, specifications, or materials without prior notice and without incurring any obligation to make such changes and modifications on Ames products previously or subsequently sold.

## Available Models

Suffix:

- S – bronze strainer
- LH – locking handle ball valves
- HC – 2 1/2" inlet/outlet fire hydrant fittings (2" valve)
- B – quarter-turn ball valves
- PC – internal polymer coating
- C&T – test cock cap & tether
- LBV – less ball valves
- A – street elbows with quarter-turn ball valves

Prefix:

- U – union connections

## Materials

Body: Bronze

Elastomers: Chloramine resistant silicone and EPDM

Check Seats and Disc Holders: PPO

## Standards

AWWA Std C510 compliant

## Approvals



## Pressure-Temperature

Operating Pressure: 175psi (12.07 bar)

Operating Temperature Range: 33°F – 180°F (5°C – 82°C)

**IMPORTANT: Inquire with governing authorities for local installation requirements.**

## Dimensions — Weights

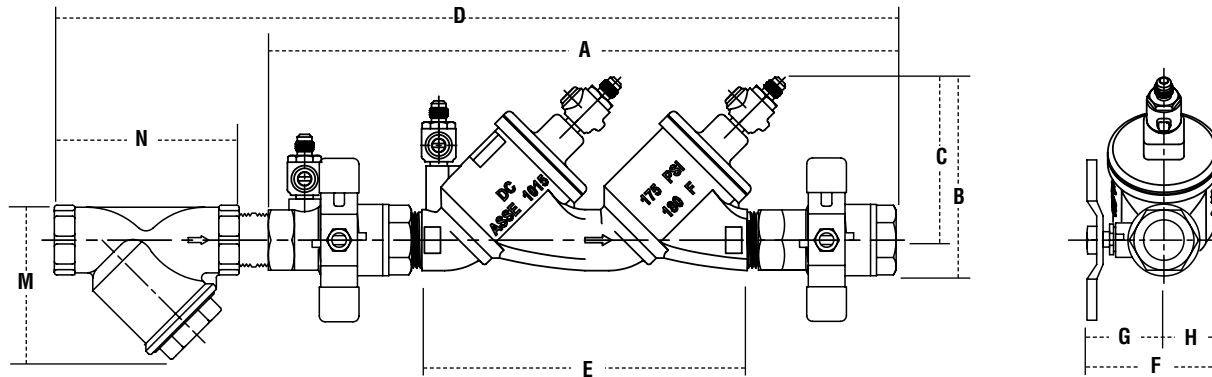

### 200B, 200B-S

SIZE (DN)		DIMENSIONS										STRAINER DIMENSIONS				WEIGHT									
		A		B		C		D		E(LF)		F		G		H		M		N		200B		200B-S	
in.	mm	in.	mm	in.	mm	in.	mm	in.	mm	in.	mm	in.	mm	in.	mm	in.	mm	in.	mm	in.	mm	lbs.	kgs.	lbs.	kgs.
1/2	15	9 <sup>9</sup> / <sub>16</sub>	242	3 <sup>11</sup> / <sub>16</sub>	94	2 <sup>15</sup> / <sub>16</sub>	73	12 <sup>9</sup> / <sub>16</sub>	318	5 <sup>13</sup> / <sub>16</sub>	147	2 <sup>7</sup> / <sub>16</sub>	62	1 <sup>11</sup> / <sub>16</sub>	43	3/4	19	1 <sup>3</sup> / <sub>8</sub>	35	2 <sup>3</sup> / <sub>4</sub>	70	2.8	1.3	3.8	1.7
3/4	20	12 <sup>7</sup> / <sub>8</sub>	307	4 <sup>1</sup> / <sub>4</sub>	108	3 <sup>1</sup> / <sub>2</sub>	88	15 <sup>7</sup> / <sub>16</sub>	393	7 <sup>11</sup> / <sub>16</sub>	195	3 <sup>1</sup> / <sub>8</sub>	79	2 <sup>1</sup> / <sub>16</sub>	52	1 <sup>1</sup> / <sub>16</sub>	27	1 <sup>5</sup> / <sub>8</sub>	41	3 <sup>3</sup> / <sub>16</sub>	81	4.7	2.1	6.4	2.9
1	25	14 <sup>13</sup> / <sub>16</sub>	376	4 <sup>9</sup> / <sub>16</sub>	116	3 <sup>7</sup> / <sub>8</sub>	98	19 <sup>1</sup> / <sub>2</sub>	495	9 <sup>5</sup> / <sub>8</sub>	244	3 <sup>3</sup> / <sub>4</sub>	95	2 <sup>7</sup> / <sub>16</sub>	62	1 <sup>5</sup> / <sub>16</sub>	33	2 <sup>1</sup> / <sub>8</sub>	54	3 <sup>3</sup> / <sub>4</sub>	95	7.4	3.4	9.4	4.3
1 1/4	32	18 <sup>15</sup> / <sub>16</sub>	480	6 <sup>1</sup> / <sub>8</sub>	156	5 <sup>1</sup> / <sub>8</sub>	129	24 <sup>1</sup> / <sub>16</sub>	610	11 <sup>11</sup> / <sub>16</sub>	297	4 <sup>1</sup> / <sub>4</sub>	108	2 <sup>5</sup> / <sub>8</sub>	67	1 <sup>5</sup> / <sub>8</sub>	41	2 <sup>1</sup> / <sub>2</sub>	64	4 <sup>7</sup> / <sub>16</sub>	113	14.0	6.3	18.0	8.1
1 1/2	40	18 <sup>15</sup> / <sub>16</sub>	480	6 <sup>1</sup> / <sub>8</sub>	156	5 <sup>1</sup> / <sub>8</sub>	129	25 <sup>1</sup> / <sub>4</sub>	640	11 <sup>11</sup> / <sub>16</sub>	297	4 <sup>3</sup> / <sub>4</sub>	121	3 <sup>3</sup> / <sub>8</sub>	79	1 <sup>5</sup> / <sub>8</sub>	41	3	76	4 <sup>7</sup> / <sub>8</sub>	124	16.1	7.3	19.9	9.0
2	50	21 <sup>3</sup> / <sub>16</sub>	538	7 <sup>1</sup> / <sub>16</sub>	179	5 <sup>5</sup> / <sub>8</sub>	142	28 <sup>15</sup> / <sub>16</sub>	735	13 <sup>3</sup> / <sub>8</sub>	340	5 <sup>3</sup> / <sub>8</sub>	137	3 <sup>7</sup> / <sub>16</sub>	87	1 <sup>15</sup> / <sub>16</sub>	49	3 <sup>9</sup> / <sub>16</sub>	90	5 <sup>15</sup> / <sub>16</sub>	151	25.7	11.6	33.4	15.2

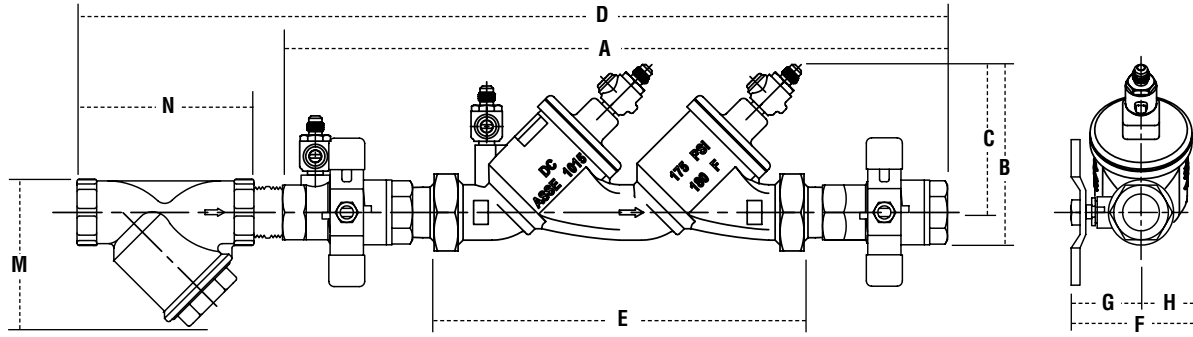

### U200B, U200B-S

SIZE (DN)		DIMENSIONS										STRAINER DIMENSIONS		WEIGHT											
in.	mm	A	B	C	D	E (LF)		F	G	H	M	N	U200B		U200B-S										
		in.	mm	in.	mm	in.	mm	in.	mm	in.	mm	in.	mm	lbs.	kgs.	lbs.	kgs.								
1/2	15	15 <sup>3</sup> / <sub>16</sub>	402	4 <sup>9</sup> / <sub>16</sub>	116	3 <sup>7</sup> / <sub>8</sub>	98	18 <sup>13</sup> / <sub>16</sub>	478	11 <sup>3</sup> / <sub>8</sub>	289	3	76	1 <sup>11</sup> / <sub>16</sub>	43	1 <sup>5</sup> / <sub>16</sub>	33	1 <sup>3</sup> / <sub>8</sub>	35	2 <sup>3</sup> / <sub>4</sub>	70	7.4	3.4	8.4	3.8
3/4	20	16 <sup>1</sup> / <sub>4</sub>	412	4 <sup>9</sup> / <sub>16</sub>	116	3 <sup>7</sup> / <sub>8</sub>	98	19 <sup>9</sup> / <sub>8</sub>	498	11 <sup>5</sup> / <sub>16</sub>	287	3 <sup>3</sup> / <sub>8</sub>	86	2 <sup>1</sup> / <sub>16</sub>	52	1 <sup>5</sup> / <sub>16</sub>	33	1 <sup>5</sup> / <sub>8</sub>	41	3 <sup>3</sup> / <sub>16</sub>	81	7.9	3.6	9.7	4.4
1	25	17 <sup>5</sup> / <sub>16</sub>	439	4 <sup>9</sup> / <sub>16</sub>	116	3 <sup>7</sup> / <sub>8</sub>	98	22	558	11 <sup>3</sup> / <sub>4</sub>	297	3 <sup>3</sup> / <sub>4</sub>	95	2 <sup>7</sup> / <sub>16</sub>	62	1 <sup>5</sup> / <sub>16</sub>	33	2 <sup>1</sup> / <sub>8</sub>	54	3 <sup>3</sup> / <sub>4</sub>	95	8.9	4.0	10.9	5.0
1 1/4	32	20 <sup>7</sup> / <sub>8</sub>	530	6 <sup>1</sup> / <sub>8</sub>	156	5 <sup>1</sup> / <sub>8</sub>	129	26	660	15 <sup>3</sup> / <sub>8</sub>	390	4 <sup>1</sup> / <sub>4</sub>	108	2 <sup>5</sup> / <sub>8</sub>	67	1 <sup>5</sup> / <sub>8</sub>	41	2 <sup>1</sup> / <sub>2</sub>	64	4 <sup>7</sup> / <sub>16</sub>	113	17.6	8.0	21.6	9.8
1 1/2	40	21 <sup>9</sup> / <sub>16</sub>	547	6 <sup>1</sup> / <sub>8</sub>	156	5 <sup>1</sup> / <sub>8</sub>	129	27 <sup>7</sup> / <sub>8</sub>	708	15 <sup>3</sup> / <sub>8</sub>	390	4 <sup>3</sup> / <sub>4</sub>	121	3 <sup>1</sup> / <sub>8</sub>	79	1 <sup>5</sup> / <sub>8</sub>	41	3	76	4 <sup>7</sup> / <sub>8</sub>	124	19.8	9.0	23.5	10.7
2	50	24 <sup>7</sup> / <sub>16</sub>	621	7 <sup>1</sup> / <sub>16</sub>	179	5 <sup>5</sup> / <sub>8</sub>	142	32 <sup>3</sup> / <sub>16</sub>	817	16 <sup>3</sup> / <sub>4</sub>	425	5 <sup>3</sup> / <sub>8</sub>	137	3 <sup>7</sup> / <sub>16</sub>	87	1 <sup>15</sup> / <sub>16</sub>	49	3 <sup>9</sup> / <sub>16</sub>	90	5 <sup>15</sup> / <sub>16</sub>	151	30.0	13.6	37.7	17.1

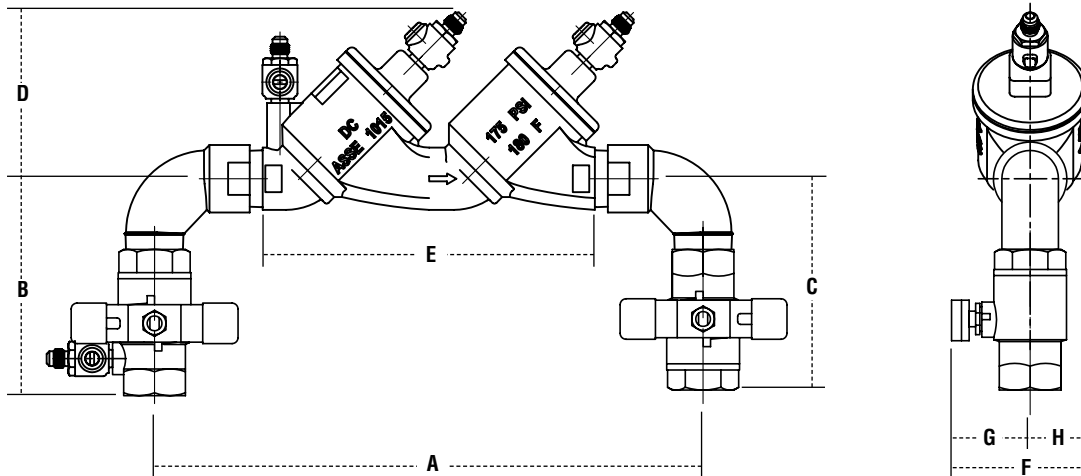

### 200B A

SIZE (DN)		DIMENSIONS										WEIGHT							
in.	mm	A	B	C	D	E (LF)		F	G	H	200B A								
		in.	mm	in.	mm	in.	mm	in.	mm	in.	mm	lbs.	kgs.						
1/2	15	7 <sup>7</sup> / <sub>8</sub>	200	3 <sup>5</sup> / <sub>16</sub>	84	2 <sup>15</sup> / <sub>16</sub>	73	2 <sup>15</sup> / <sub>16</sub>	73	5 <sup>13</sup> / <sub>16</sub>	147	2 <sup>7</sup> / <sub>16</sub>	62	1 <sup>11</sup> / <sub>16</sub>	43	3 <sup>4</sup> / <sub>4</sub>	19	3.4	1.5
3/4	20	13 <sup>7</sup> / <sub>16</sub>	340	4 <sup>13</sup> / <sub>16</sub>	121	4 <sup>9</sup> / <sub>16</sub>	116	3 <sup>1</sup> / <sub>2</sub>	98	7 <sup>11</sup> / <sub>16</sub>	195	3 <sup>1</sup> / <sub>8</sub>	79	2 <sup>1</sup> / <sub>16</sub>	52	1 <sup>1</sup> / <sub>16</sub>	27	5.7	2.6
1	25	12 <sup>11</sup> / <sub>16</sub>	322	5	127	4 <sup>3</sup> / <sub>8</sub>	110	3 <sup>7</sup> / <sub>8</sub>	98	9 <sup>5</sup> / <sub>8</sub>	244	3 <sup>3</sup> / <sub>4</sub>	95	2 <sup>7</sup> / <sub>16</sub>	62	1 <sup>5</sup> / <sub>16</sub>	33	8.9	4.0
1 1/4	32	15 <sup>3</sup> / <sub>16</sub>	386	5 <sup>11</sup> / <sub>16</sub>	144	5 <sup>11</sup> / <sub>16</sub>	144	5 <sup>1</sup> / <sub>8</sub>	129	11 <sup>11</sup> / <sub>16</sub>	297	4 <sup>1</sup> / <sub>4</sub>	108	2 <sup>5</sup> / <sub>8</sub>	67	1 <sup>5</sup> / <sub>8</sub>	41	15.7	7.1
1 1/2	40	15 <sup>13</sup> / <sub>16</sub>	401	6 <sup>3</sup> / <sub>16</sub>	156	6 <sup>3</sup> / <sub>16</sub>	156	5 <sup>1</sup> / <sub>8</sub>	129	11 <sup>11</sup> / <sub>16</sub>	297	4 <sup>3</sup> / <sub>4</sub>	121	3 <sup>1</sup> / <sub>8</sub>	79	1 <sup>5</sup> / <sub>8</sub>	41	18.4	8.3
2	50	17 <sup>3</sup> / <sub>8</sub>	441	6 <sup>5</sup> / <sub>8</sub>	168	6 <sup>9</sup> / <sub>16</sub>	167	5 <sup>5</sup> / <sub>8</sub>	142	13 <sup>3</sup> / <sub>8</sub>	340	5 <sup>3</sup> / <sub>8</sub>	137	3 <sup>7</sup> / <sub>16</sub>	87	1 <sup>15</sup> / <sub>16</sub>	49	29.0	13.1

# Capacities

\* Typical maximum flow rate (7.5 feet/sec.)

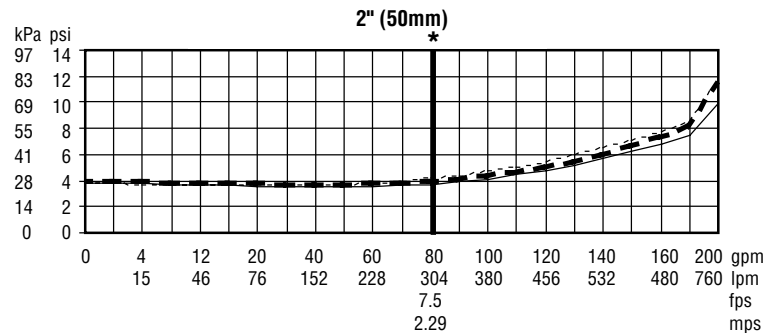
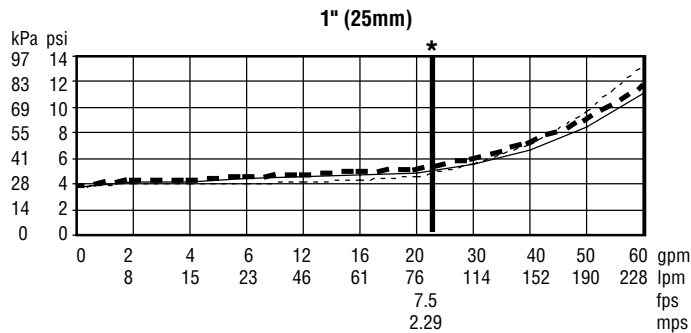
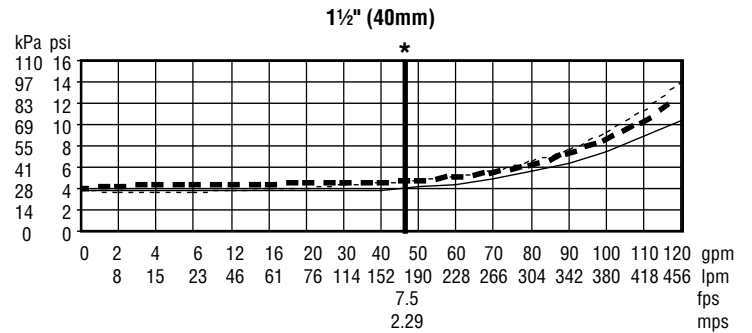
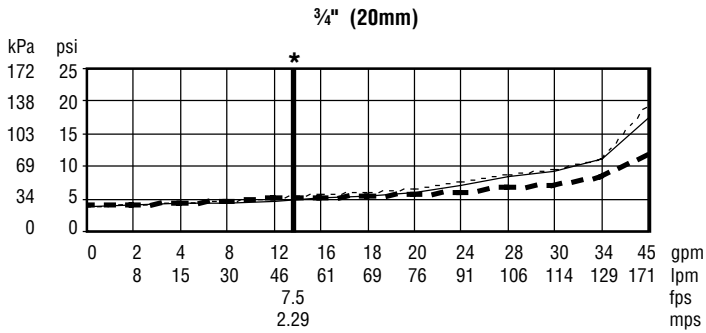
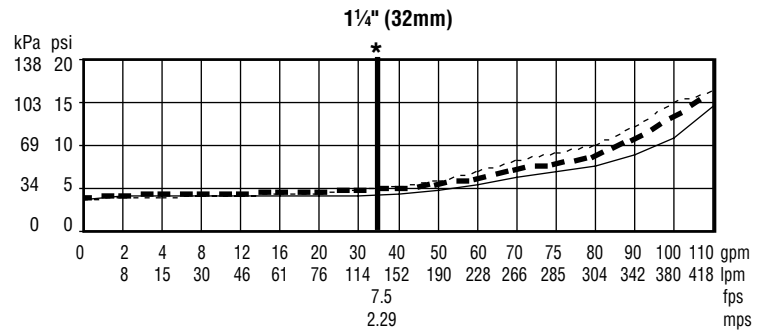
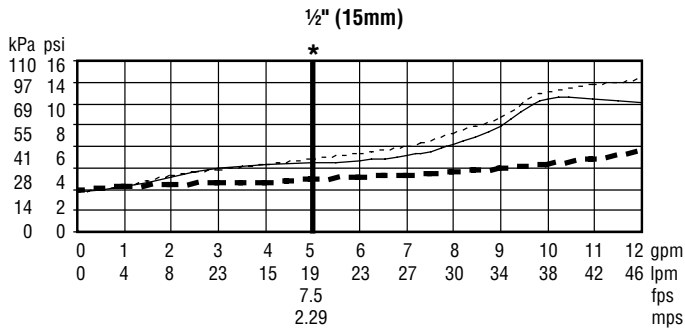

A Watts Water Technologies Company

[www.amesfirewater.com](http://www.amesfirewater.com)



USA: **Backflow-** Sacramento, CA • Tel: (916) 928-0123 • Fax: (916) 928-9333  
**Control Valves-** Houston, TX • Tel: (713) 943-0688 • Fax: (713) 944-9445  
**Canada:** Burlington, ON • Tel: (905) 332-4090 • Fax: (905) 332-7068