

Series 611

Valve Setter - Flange by Flange Used with MasterSeries® N-Shape Assemblies

Sizes: 2½" - 10" (65mm-250mm)



Series 611
U.S. Patent No. 5,392,803

The FEBCO Series 611 Flange by Flange Valve Setter is constructed of fusion epoxy coated ductile iron. Valve setters are designed to augment the installation of the "N" series backflow prevention valves. Integral ductile iron support between elbow transfers thrust downstream, thus eliminating thrust block requirements between elbows.

Features

- Corrosion resistant fusion epoxy coated.
- Eliminates the need for thrust blocks or other restraints at the point of installation.
- Flanges: ANSI B16.1 Class 125 (Standard)
ISO 7005-2 (Optional. Contact factory for dimensions.)
AS 2129 (Optional. Contact factory for dimensions.)

Pressure – Temperature

Maximum Working Pressure: 175psi (12.1 bar)
Temperature Range: 32° to 140° (0°C to 60°)

Dimensions – Weights

Size: 2½" - 10" (65 - 250mm)

SIZE (DN)		DIMENSIONS						WEIGHTS	
in.	mm	A		B		C		lbs.	kgs.
		in.	mm	in.	mm	in.	mm		
2½	65	23½	597	12½	318	5½	140	73	33.1
3	80	23½	597	12½	318	5½	140	73	33.1
4	100	27	686	14	356	6½	165	100	45.4
6	150	32	813	16	406	8	203	144	65.3
8	200	36½	927	18½	470	9	229	228	103.4
10	250	43	1092	21	533	11	279	310	140.6

Note: Dimensions shown are nominal. Allowances must be made for normal manufacturing tolerances.

Materials

Body: Ductile iron A536 GR 65-45-12
Coating: Fusion epoxy coated internal and external
AWWA C550
Bolts & Nuts: Stainless steel
* Flange bolts and gaskets are not included (except for center joint).

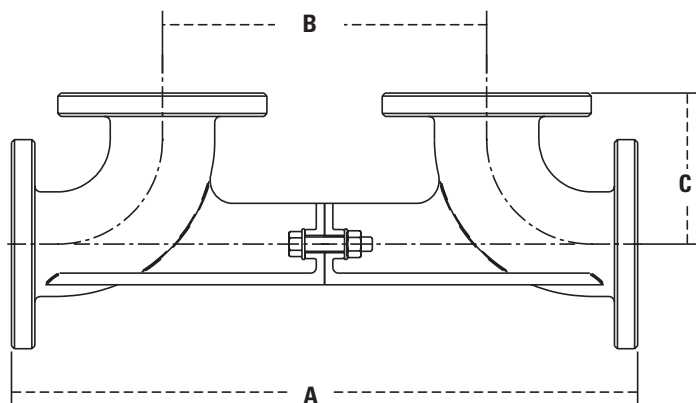

Job Name _____

Job Location _____

Engineer _____

Approval _____

Contractor _____

Approval _____

Contractor's P.O. No. _____

Representative _____



FEBCO product specifications in U.S. customary units and metric are approximate and are provided for reference only. For precise measurements, please contact FEBCO Technical Service. FEBCO reserves the right to change or modify product design, construction, specifications, or materials without prior notice and without incurring any obligation to make such changes and modifications on FEBCO products previously or subsequently sold.



USA: 4381 N. Brawley • Ste. 102 • Fresno, CA • 93722 • Tel. (559) 441-5300 • Fax: (559) 441-5301 • www.FEBCOonline.com
Canada: 5435 North Service Rd. • Burlington, ONT. • L7L 5H7 • Tel. (905) 332-4090 • Fax: (905) 332-7068 • www.FEBCOonline.ca

A Watts Water Technologies Company