

Models: 125, 125-B

Cast Iron or Cast Bronze Screwed End Simplex Basket Strainers Sizes: 3/8" - 3" (10 - 80mm)

Pressure/Temperature - Non-Shock		
Model	Material	Rating
125	Cast iron	200psi @ -20 to 150°F
		13.79 bar @ 65.56°C
		165psi @ 300°F
125B	Bronze	11.38 bar @ 148.89°C
		175psi @ -20 to 150°F
		12.07 bar @ 65.56°C
		200psi @ 150°F
		13.79 bar @ 65.56°C

Max. temp. can be limited by O-ring material. Consult factory. All units with knob type enclosure are rated 200psi.

125 Cast Iron **Class 125**
125-B Bronze **Class 125**



Model 125

Strainers provide economical protection for costly pumps, meters, valves, and other similar mechanical equipment by straining foreign matter from the connected piping system. Installation of a strainer before mechanical equipment can ensure trouble free service and avoid costly shutdowns for repair or replacement of equipment damaged by foreign matter. The size of the perforation or mesh in the basket screen will determine the smallest particles captured. See Strainer Information section of Mueller Steam Specialty Engineering binder for detailed information including sizes and materials available.

Typical Service

- These strainers can be specified for cooling water, seawater, hot water systems and more.

Features

- Designed for large capacity straining and ease of maintenance.
- Cover is secured with quick-opening knobs to minimize service time.
- O-ring seals on both the cover and baskets can usually be re-used after service, no need to clean gasket residue and replace costly gaskets.
- Machined basket seat eliminates particle bypass.

Construction

- Standard cover has O-ring seal and quick release knob fasteners.
- Bolted cover available, consult factory
- Swing clamp covers are available, consult factory
- Plugged NPT connection is provided at location D. (See next page.)

Capacity

Minimum 6 to 1 ratio.

Galvanizing

Available on cast iron models. Other coatings are available on application.

Baskets

MODEL	SIZES	STANDARD (WATER)		STEAM RECOMMENDATION	
		MATERIAL	OPENING	MATERIAL	OPENING
125	3/8" - 3"	304SS	.062 perf	304SS	.062 perf
125B	3/8" - 3"	304SS	.062 perf	304SS	.062 perf

Job Name _____
 Job Location _____
 Engineer _____
 Approval _____

Contractor _____
 Approval _____
 Contractor's P.O. No. _____
 Representative _____

Materials

	125	125-B
Body	Cast Iron ASTM A126-B	Bronze ASTM B62
Cover	Cast Iron ASTM A126-B	Bronze ASTM B62
O-Ring	Buna-N	Buna-N

Pressure Drop

See Pressure Drop Charts in Technical Data section of the Mueller Steam Specialty Engineering binder.

Dimensions and Weights

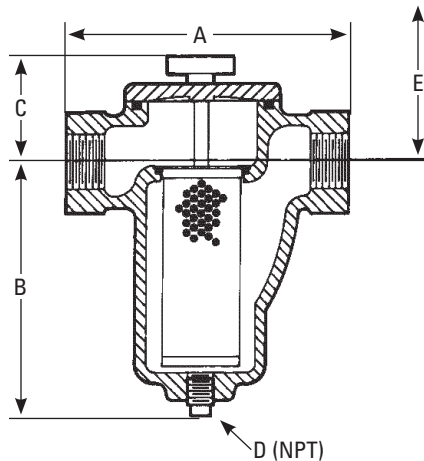

SIZE		DIMENSIONS								WEIGHT					
		A		B		C		D (NPT)		E SCREEN REMOVAL		CAST IRON		BRONZE	
in.	mm	in.	mm	in.	mm	in.	mm	in.	mm	in.	mm	lbs.	kgs.	lbs.	kgs.
3/8	10	4 9/16	116	4	102	2 1/2	64	3/8	10	4 13/16	106	4.8	2.1	5.3	2.3
1/2	15	4 9/16	116	4	102	2 1/2	64	3/8	10	4 13/16	106	4.8	2.1	5.3	2.3
3/4	20	4 9/16	116	4	102	2 1/2	64	3/8	10	4 13/16	106	4.8	2.1	5.3	2.3
1	25	5 5/16	135	4 11/16	119	2 3/4	70	3/8	10	5 7/8	149	6	2.7	7.8	3.5
1 1/4	32	6 5/16	160	6 1/2	165	3	76	1/2	15	8 1/8	206	10	4.6	12.5	5
1 1/2	40	6 5/16	160	6 1/2	165	3	76	1/2	15	8 1/8	206	10	4.6	12.5	5
2	50	8 1/4	210	7 7/8	200	3 5/8	92	3/4	20	10 1/8	257	19.5	8	24.5	11
2 1/2	65	9 5/8	244	8 3/4	222	4	102	1	25	11 7/16	590	28.5	12	36.5	16
3	80	11 1/4	286	11 3/8	289	4 1/2	114	1	25	14 13/16	376	47	21	55.5	25

Mueller Steam Specialty product specifications in U.S. customary units and metric are approximate and are provided for reference only. For precise measurements, please contact Mueller Steam Specialty Technical Service. Mueller Steam Specialty reserves the right to change or modify product design, construction, specifications, or materials without prior notice and without incurring any obligation to make such changes and modifications on Mueller Steam Specialty products previously or subsequently sold.



A Watts Water Technologies Company

ES-MS-125-125B 1020



USA: St. Pauls, NC • Tel. 1-800-334-6259 • Fax 1-800-421-6772 • www.muellersteam.com

© 2010 Mueller Steam Specialty