

# MicroSCM Streaming Current Monitor

## Instrument Overview

The instrument consists of the Analyzer and the SCM sensor.



MicroSCM Analyzer

## The Analyzer

The MicroSCM monitor has a built in graphic recorder, which displays SCU (Streaming Current Unit) readings for the previous eight hour or 24 hour period.

Calibration and set point values are stored in non-volatile memory so no loss is experienced in case of a power outage. The entire process is menu driven and intuitive. Using the optional printer and RS-232 output the MicroSCM can provide printouts showing date, time, alarm settings and current reading.



MicroSCM Sensor/Sampler  
with light shield removed

## SCM Detailed Sensor Description

The MicroSCM works on the principle of generating a current by forcing a flow of charged particles between two electrodes.

Figure 5. Shows a diagram of the Streaming Current Sensor. A continuous sample is directed into an annulus. Inside a displacement piston, or probe, oscillates at a fixed frequency. The oscillating movement of the piston causes the liquid sample to flow along the inner wall of the cell.

Suspended particles are adsorbed onto the walls under the action of Van der Waal's and electrostatic forces. As the sample is moved rapidly back and forth, mobile counter ions, surrounding the charged particles, or colloids, are sheared near the surface of the particle and moved past the electrodes. A potential difference is induced between the two electrodes at the top and base of the cell. The resultant potential developed, proportional to charge is electronically processed to give a reading of the streaming current in micro-amps.

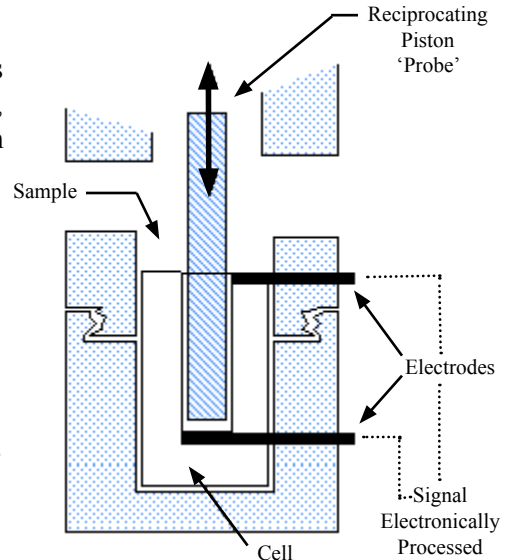

The streaming current detector has been calibrated to give a negative reading if the particles in suspension are negatively charged, and similarly a positive reading for a positively charged system. The greater the magnitude of the current, the higher the charge of the system being measured and consequently the greater the mutual repulsion between the particles in the suspension.

This fact is fundamental to the use of the instrument, as it allows the measurement on line of the ionic charge of a water system, and from the value obtained, decisions can be made to optimize the dosage of coagulants used for water clarification.

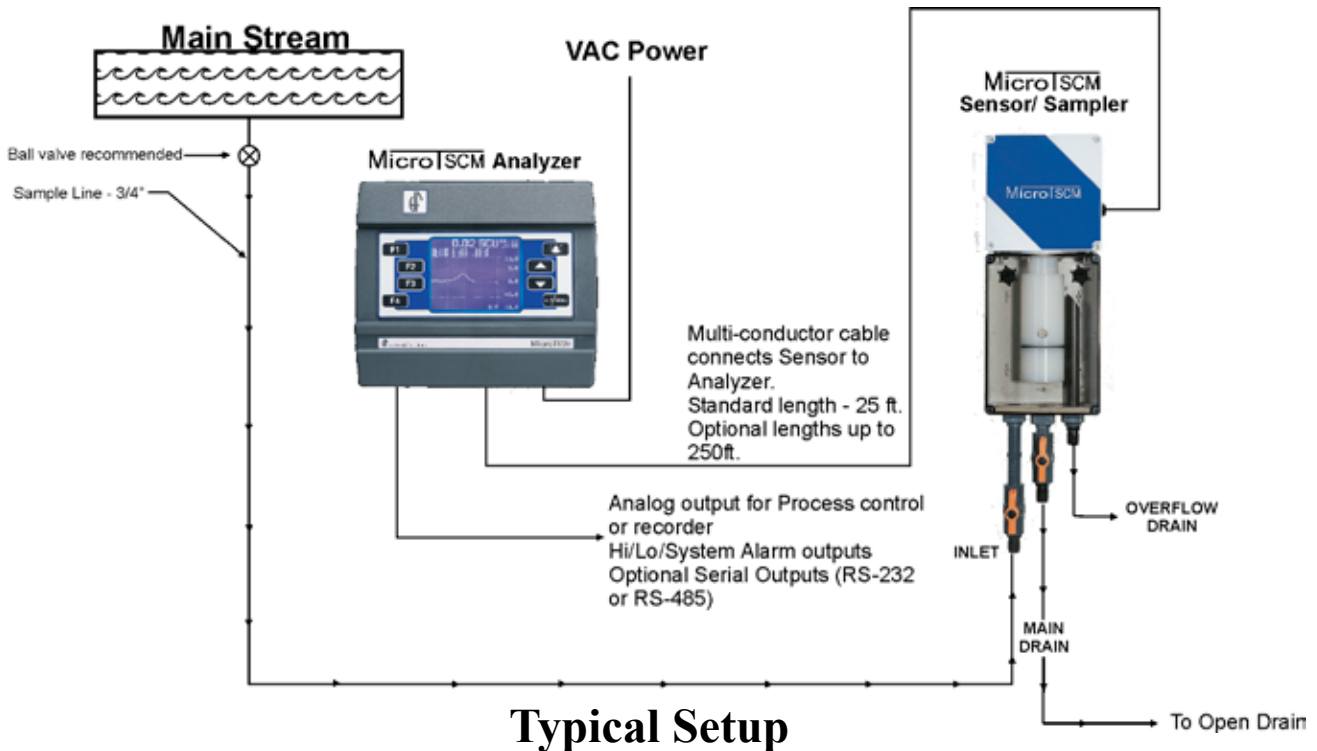

### 3.3 Sensor Mounting & Plumbing

Locate the sensor as close to the dosing point as possible, but far enough away to ensure adequate mixing. While a protected site is desirable, the sensor is rugged enough to withstand most outdoor conditions. The sample chamber is designed to be surface mounted using #10 bolts.

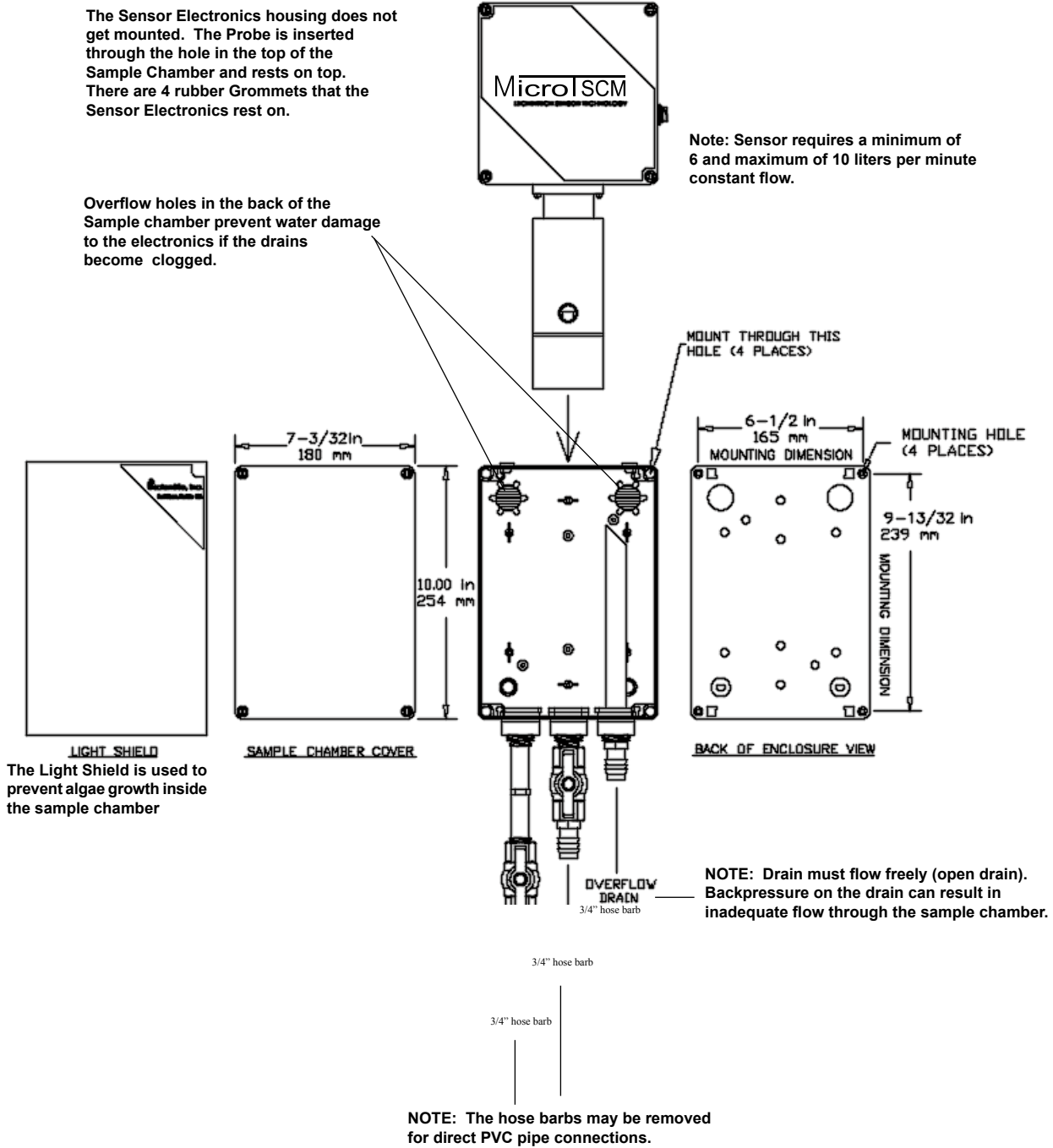

## Analyzer Mounting Diagram

For ease of calibration, it is recommended that the analyzer be located in close proximity to the sensor. The standard cable length between the sensor and analyzer is 25 ft. If necessary, the Analyzer can be located up to 250 ft from the sensor.

The analyzer should be installed in a location that avoids direct water contact. Avoiding direct glare from windows and lights will make the reading the display easier. Be sure to mount the Analyzer at a comfortable height so that all adjustments can be accomplished with ease.

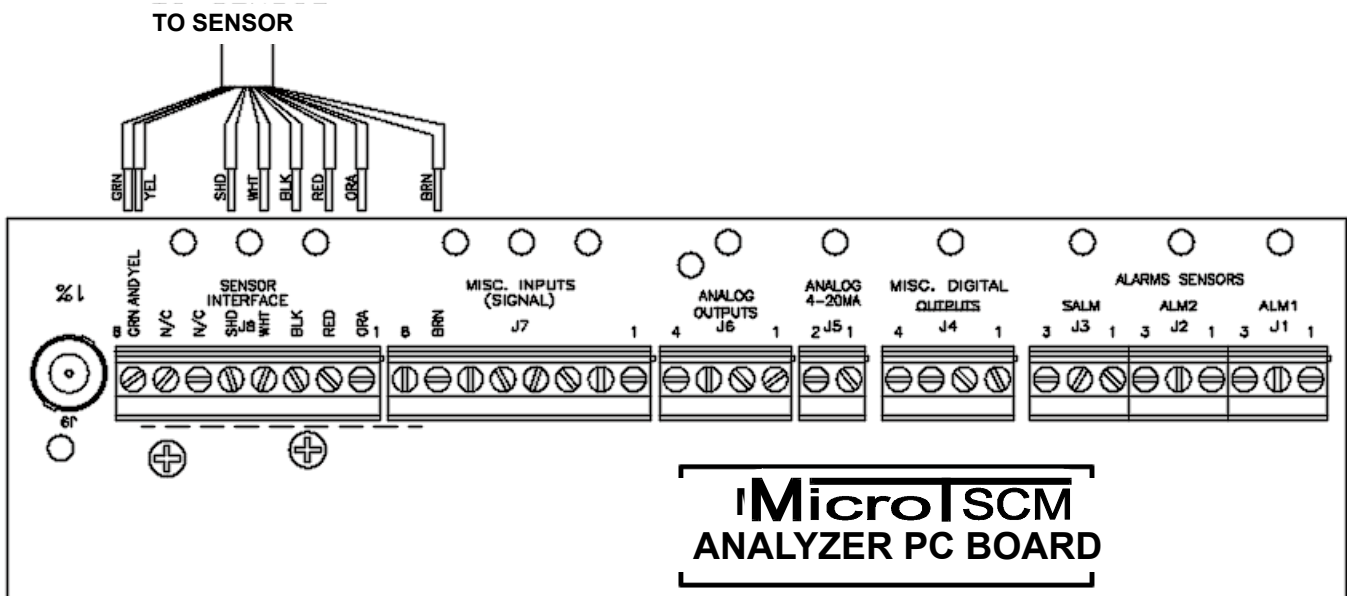
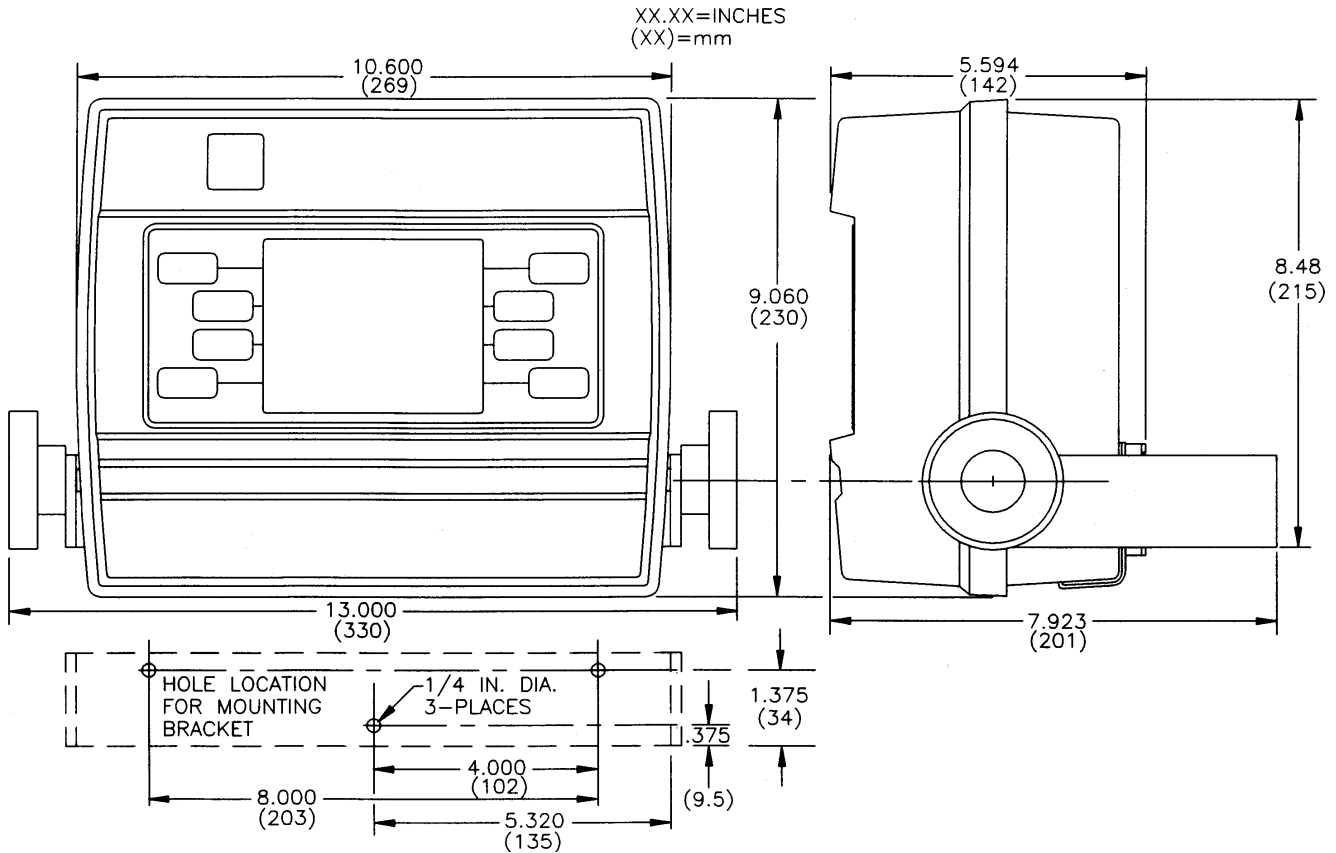

## SPECIFICATION

|                                      |   |
|--------------------------------------|---|
| Ranges:                              | ± 10 SCU (Streaming Current Units)  |
| Method:                              | Ion Charge Analysis through induced electrical potential                              |
| Accuracy:                            | ± 1% of full scale  |
| Repeatability:                       | 1%  |
| Resolution:                          | 0.01 ICu (SCU)  |
| Display:                             | Graphical trending and LCD numeric  |
| Clock Graphics:                      | Date and Time   |
| Response Time:                       | 1 second  |
| Averaging Time (Electronic):         | 1, 15, 30 & 60 seconds, sliding average   |
| Microprocessor:                      | Motorola MC68HC11   |
| Keyboard data entry system:          | 8 interacting membrane switches with tactile feedback                                 |
| Built in diagnostics:                | Yes   |
| Analog Output, Isolated:             | 4 - 20 mA, 0 - 10 VDC   |
| Computer Interface Serial Port:      | Option - RS-232 & RS-485 (optional)   |
| Alarms:                              | 1 System alarm, 2 User settable Hi/Lo/Off), 1 Flow Alarm (requires optional hardware) |
| Alarm Contact rating:                | Max. 250 VAC @ 5.0 A  |
| Operating Temperature:               | 32° - 122°F (0 - 50°C)  |
| Flow rate:                           | Up to 10 G/min  |
| Positive System Pressure:            | 60 psi maximum  |
| Wetted surfaces:                     | HDPE, PTFE, Stainless Steel, Neoprene, ABS  |
| Standard Cable Length:               | 25 feet (7.62 meters)   |
| Maximum Sensor to analyzer distance: | 250 feet (914.41 meters) - 3000 ft with optional amplifier.                           |
| Dimensions                           | Analyzer: 13" x 11½" x 8" (330 x 290 x 200 mm)  |
| SCM Sensor & Sample Chamber:         | 16" x 6.25" x 3.5" (406 x 159 x 89 mm)  |
| Analyzer Case:                       | IP 65   |
| Sensor Case:                         | NEMA 4X   |
| Supply Voltage:                      | 120/240 VAC + 10% 50/60 Hz  |
| Power Consumption:                   | 40 VA   |
| Shipping Weight:                     | Approximately 15 lbs. (6.8 kg.)   |
| Warranty:                            | One year from date of shipment  |

## MicroSCM

### Written Specification (Sample)

The instrument shall be a Streaming Current monitor that continuously monitors the particle charge in a sample stream and report the results in Ion Charge Units (ICu). In addition to displaying ICu the monitor shall have the ability to display graphical trending of readings over a user selectable time period of eight or 24 hours.

Streaming current monitor shall have a flow-through sample chamber which enables heavy solids and light particulates to be removed before entering the sensor cell and probe. Unit must be able to handle continuous flows up to 10 GPM.

The Controller shall have two independent alarms, an isolated, 4-20 mA output, optional addressable RS-232 port, and a full scale range ± 10 ICu. The outputs shall be adjustable to be bracketed to any portion of the range to within 0.01 ICu. All operations including calibration and alarm setpoints shall be accomplished using menu driven software. All operational data shall be stored in non-volatile RAM, external battery backup will be required. The alarm set points and status of each alarm shall be continuously visible on the display. The controller shall include optional PI control software to allow it to directly control a dosing pump to a pre-set ICu value.

The sensor will send a frequency-based signal to the analyzer to eliminate interference and allow the analyzer to be mounted as far as 250 feet away from the sensor. To ensure the integrity of the output and compensate for any standard wear and tear on the probe and electronics; the Streaming Current Monitor shall be calibrated using a cationic polymer solution with a known Ion Charge value.

The Streaming Current Monitor shall be a MicroSCM as manufactured by HF scientific, inc. of Fort Myers, Florida.

## Installation

The first consideration is the sample point. You will be sampling the raw water after the introduction of coagulant. The sample point should be at least 10 pipe diameters away from the dosing point to ensure ample mixing time. Avoid getting too close to an elbow or tee in the pipe.

The absolute minimum flow required is 6 liters per minute. You will want to locate the sensor as close to the sample point as possible. The shorter the distance between the sample point and the sensor, the faster the response time will be.

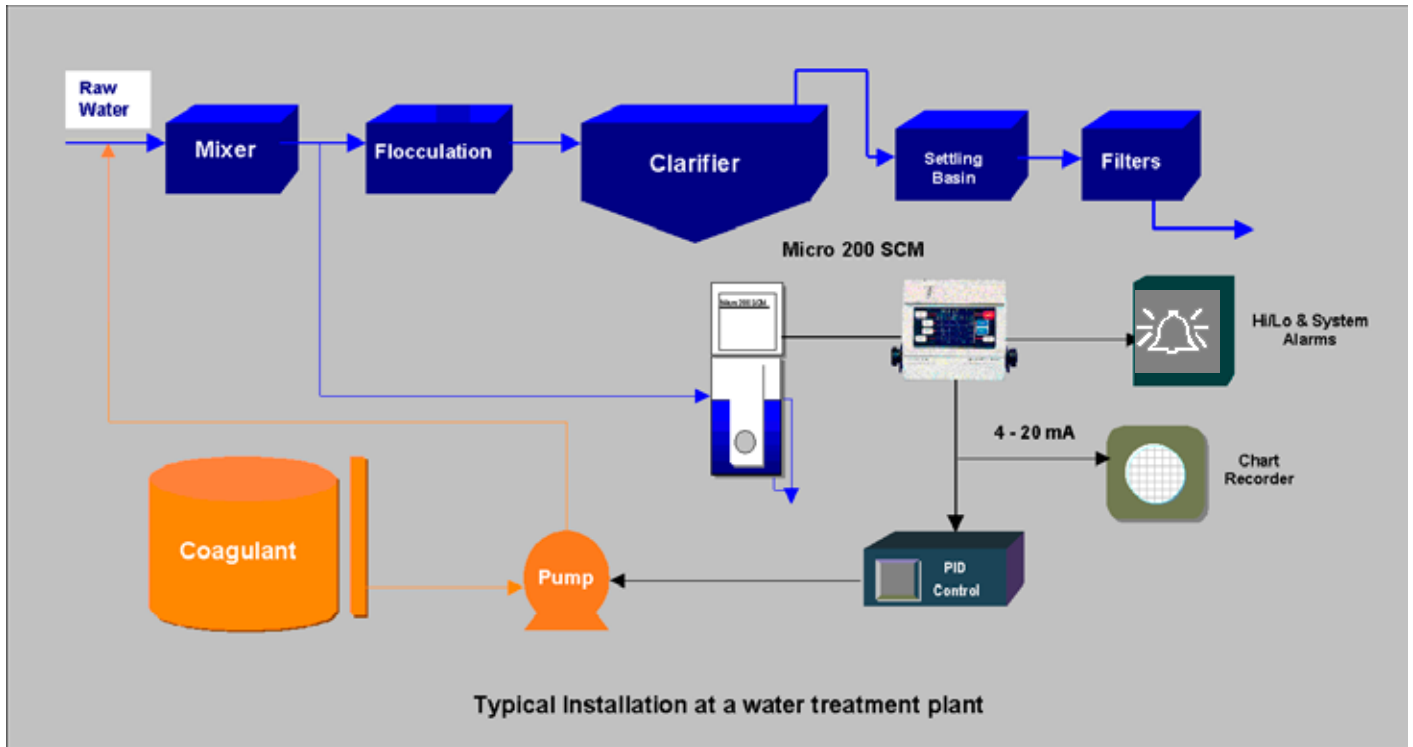

### Ordering Information

| Catalog No. | Description |
|-------------|-------------|
|-------------|-------------|

|       |   |
|-------|---|
| 19549 | MicroSCM I, 115V/240 VAC, 50/60 Hz                  |
| 19550 | MicroSCM II, with built-in PI Controller            |
| 19553 | MicroSCM III, with built-in PI controller and RS232 |
| 19554 | MicroSCM IV, with built-in PI Controller and RS485  |

### Accessories

|       |   |
|-------|---|
| 19886 | Flow Alarm, provides a remote alarm for inadequate sample flow. |
| 19922 | Calibration Kit   |
| 19986 | Nema 4X Housing for outdoor installation of monitor             |
| 19994 | Spare Cell and Probe Set  |

**HF scientific**  
 3170 Metro Parkway  
 Ft. Myers, FL 33916-7597  
 Phone: (239) 337-2116  
 Toll Free: 888-203-8-7248  
 Fax: (239) 332-7643  
 Email: [HFinfo@watts.com](mailto:HFinfo@watts.com)

PRINTED IN USA DOCUMENT