

Product Specification

Specifications ■

Description	Wall mounted, 30° Fixed head with Threaded/Sweat Connection
Material	Brass
Finish	Polished Chrome
Agency/Spec Approval	ANSI A112.18.1M CSA B125
Maximum Flow	2.5 gpm @ 80psi (9.5 l/min @550 kPa)
Shipping Weight	3.1 lb (1.4 kg)

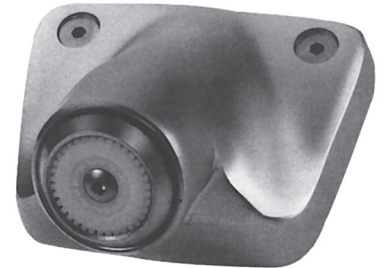

Dimensions ■

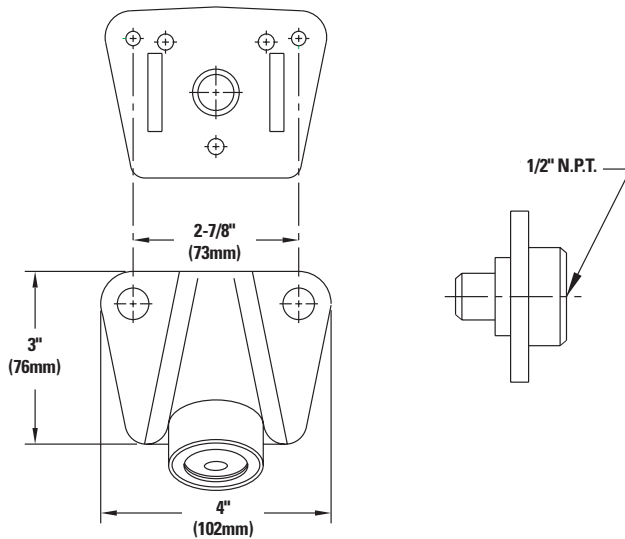

ENGINEERING APPROVAL	
Project:	_____
Contractor:	_____
Architect/Engineer:	_____

