

Product Specification

Specifications ■

Description	Hand Shower with 23" with Slide Bar, Type 9
Finish	Chrome Plated
Agency/Spec Approval	ANSI A112.18.1M CSA B125
Maximum Flow	2.5 gpm @ 80psi (9.5 l/min @550 kPa)
Shipping Weight	2.0 lbs. (0.9 kg.)

Dimensions ■

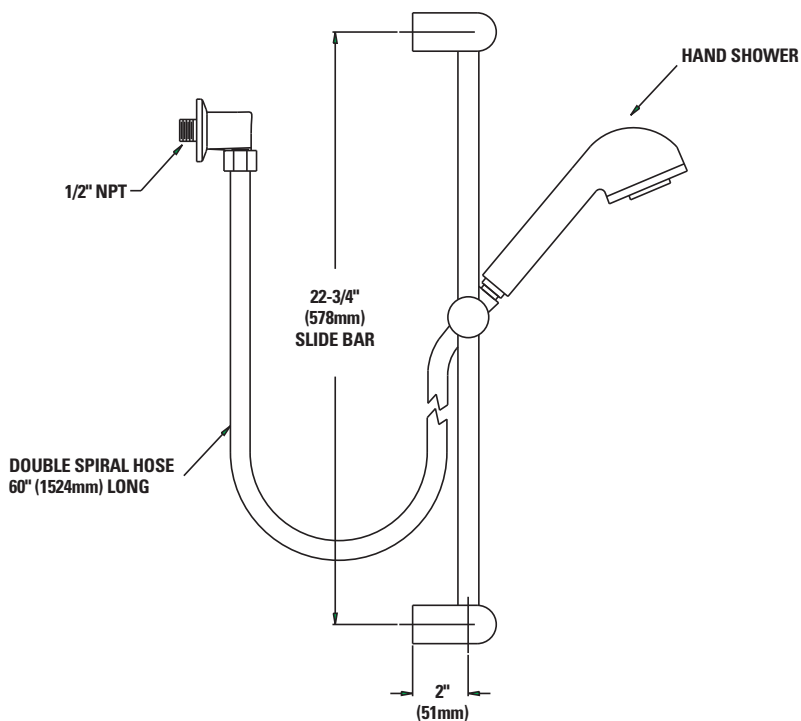

ENGINEERING APPROVAL

Project: _____
 Contractor: _____
 Architect/Engineer: _____

