

**4" Centerset Metering Faucet
Fitting No. P1005**

Product Specification

Specifications ■

Product 4" Centerset
Metering Faucet
Finish Polished Chrome

Agency/Spec Approvals:
 • ANSI A112.18.1M
 • CSA B125
 • ADA-compliance where noted on drawing 

Maximum Flow Rates 2.0 gpm at 60psi
(7.6 L/min. at 410 kPa)

Maximum Operating Pressure Rating 125psi (860 kPa)

Maximum Operating Temperature Rating 150°F (65°C)

Approximate Shipping Weight (± 0.25 lbs/±0.11 kg) .. 4.6 lbs. (2.1 kg)

Dimensions See Submittal Drawing
on reverse

Tolerances on Center to Center ±1/4" (±6 mm)

Inlet Connection Type and Size See Submittal Drawing
on reverse

Body Construction Brass

Handles Brass



Ordering Information ■

Outlets

0.5 gpm (1.6 L/min) Aerator
 2.0 gpm (7.6 L/min) Laminar Flow Outlet
 2.0 gpm (7.6 L/min) Spray Face
 Vandal Resistant Aerator (0.5 gpm, 1.9 L/min)
 Vandal Resistant Aerator (2.0 gpm, 7.6 L/min ^{7/16})
 2.0 gpm (7.6 L/min) Vandal Resistant Flow

Others

Chain Stay, Plug and Drain (P3903)
 Grid Drain (P3902)

Order Code

A5
 LF
 SF
 V5
 VA
 VF

CS
 GD

P1005

Dimensions ■

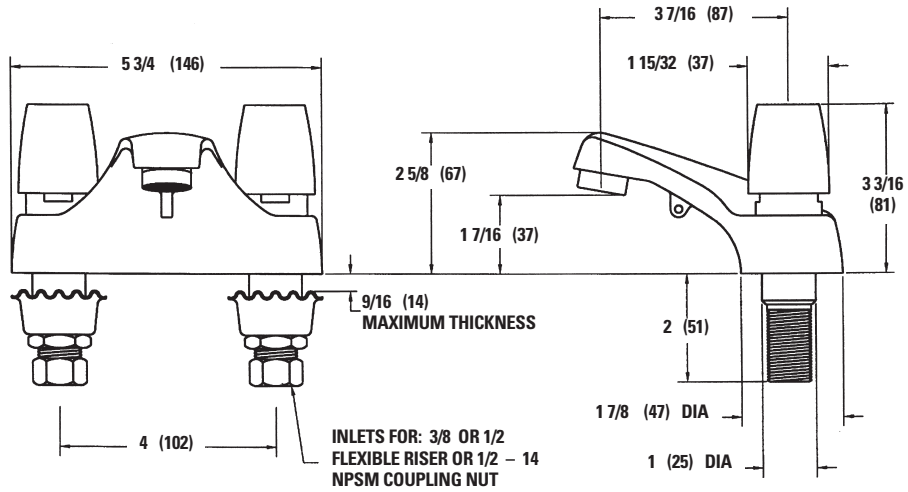

Dimensions in Inches (Millimeters)

Roughing in dimensions may vary and are subject to change. No responsibility is assumed for use of superseded or voided data.

ENGINEERING APPROVAL

Project: _____
 Contractor: _____
 Architect/Engineer: _____

POWERS™

A Watts Water Technologies Company



ISO 9001-2000
 CERTIFIED

USA: Phone: 1.800.669.5430 • Fax 1.847.229.0526 • www.powerscontrols.com
 Canada: Phone: 1.888.208.8927 • Fax 1.888.479.2887 • www.powerscontrols.ca