

Product Specification

LEAD FREE*

Features ■

- Features Lead Free* construction to comply with Lead Free* installation requirements.
- Paraffin-based advanced thermal actuation technology to sense and adjust outlet temperature
- Dirt and lime resistant poppet and seat design
- Virtual shutoff if supply pressure fails
- Factory tested valve and piping
- Triple-duty checkstops with filters, dial-thermometer, ball valve
- Rough bronze and chrome finishes

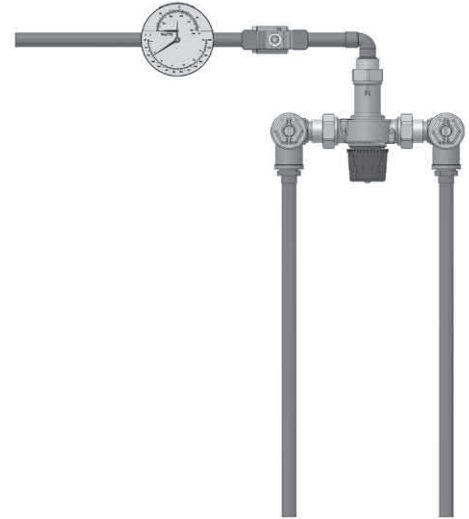

Specifications ■

- Connections 1/2" (15mm) inlets and outlet
- Maximum Hot Water Supply Temperature 200°F (93°C)
- Minimum Hot Water Supply Temperature 5°F (3°C) above set point
- Minimum Flow** 0.5 gpm (1.9 lpm)
- Maximum Operating Pressure 150psi (1034 kPa)
- Temperature Adjustment Range 90 – 160°F (32 – 71°C)
- Listing/Compliance (Valve Only) ASSE 1017, IAPMO UPC and CSA B125



* The wetted surface of this product contacted by consumable water contains less than one quarter of one percent (0.25%) of lead by weight.
 ** When tested in accordance with ASSE 1017

Capacity ■

Flow Capacity at 50-50 Mixed Ratio							
Pressure Drop Across Valve							
Valve	C _v	5psi (34 kPa)	10psi (69 kPa)	20psi (138 kPa)	30psi (207 kPa)	45psi (310 kPa)	60psi (414 kPa)
LFLM490	3.42	7.6 gpm (29 lpm)	11.0 gpm (42 lpm)	15.0 gpm (57 lpm)	19.0 gpm (72 lpm)	23.0 gpm (87 lpm)	27.0 gpm (102 lpm)

Dimensions ■

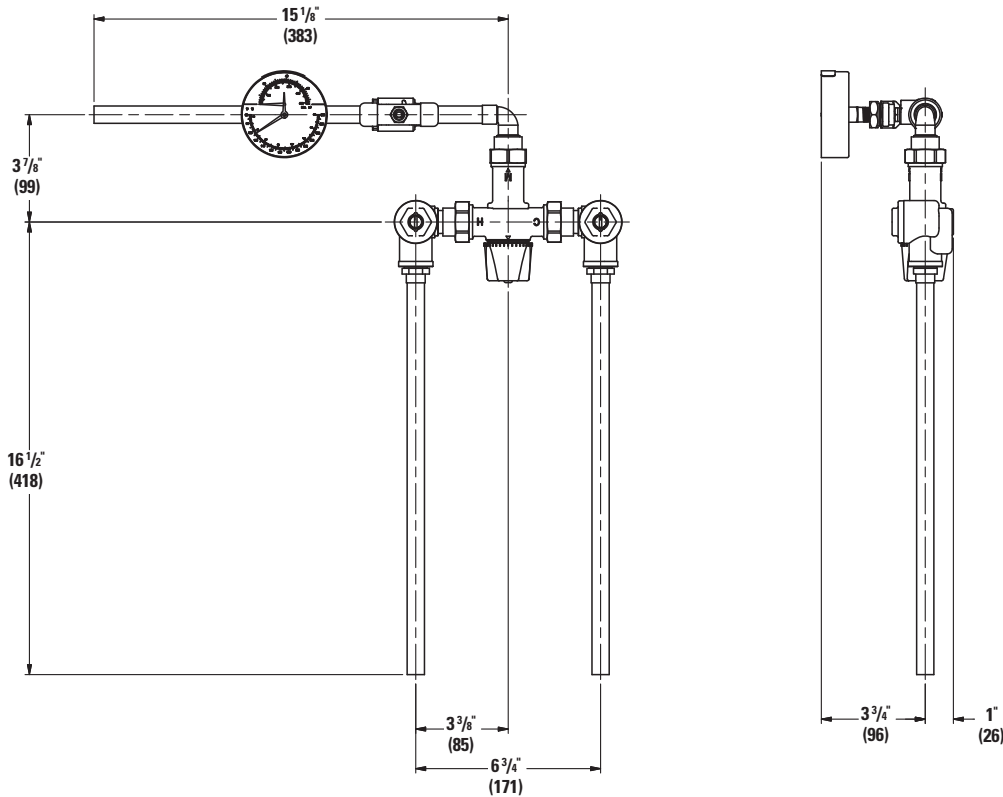

Note:
Dimensions are shown
 $\pm 1/2''$
Dimensions in parentheses
are in mm

Ordering Information ■

L F L M 4 9 0 G M S

Valve

23 gpm (87 lpm)

Order Code

LFLM490

Finish

Rough Bronze
Chrome Plated

A
C

Piping Inlets/Outlet

Bottom/Side

G

Cabinet Style

Exposed

M

Alarm System

None

Option

None
Cold Water Bypass
T/P Gauge on Inlets
C/W Bypass & T/P Gauge on Inlets

Temperature Range

90°F - 160°F (32°C - 71°C)

Order Code

0

0

2

4

6

S

Typical Specification ■

Supply Fixture shall be factory assembled and tested and feature a HydroGuard® LFLM490 Series Master-Tempering Valve with advanced, paraffin-based actuation technology. The valves shall be constructed using Lead Free* brass. Lead Free* brass valves shall comply with state codes and standards, where applicable, requiring reduced lead content. Supply Fixture shall also include copper piping, ball valve(s) and temperature/pressure gauge for diagnostics. The tempering valve shall have union checkstops, an outlet temperature range of 90 – 160°F (32 – 71°C) (with lockable means), and an approach temperature of 5°F (3°C). Valve shall be ASSE 1017, IAPMO UPC listed and CSA certified. Minimum flow to ASSE 1017 shall be 0.5 gpm (1.9 lpm).
Valve shall be a Powers model _____. All alternatives must have written approval prior to bidding.

ENGINEERING APPROVAL

Project: _____
Contractor: _____
Architect/Engineer: _____

POWERS™

A Watts Water Technologies Company



ISO 9001-2000
CERTIFIED

USA: Phone: 1.800.669.5430 • Fax 1.847.229.0526 • www.powerscontrols.com
Canada: Phone: 1.888.208.8927 • Fax 1.888.479.2887 • www.powerscontrols.ca