

Product Specification

LEAD FREE*

Features ■

- Features Lead Free* construction to comply with Lead Free* installation requirements.
- Paraffin-based advanced thermal actuation technology to sense and adjust outlet temperature
- Dirt and lime resistant poppet and seat design
- Virtual shutoff if supply pressure fails
- Stainless steel or white painted cabinets
- Factory tested valve and piping
- Triple-duty checkstops with filters, dial-thermometer, ball valve
- Rough bronze and chrome finishes

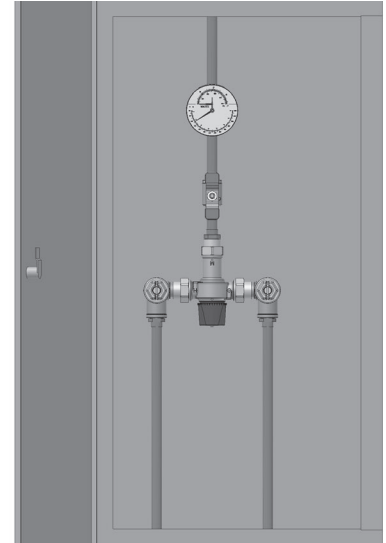

Specifications ■

- Connections 1/2" (15mm) inlets and outlet
- Maximum Hot Water Supply Temperature 200°F (93°C)
- Minimum Hot Water Supply Temperature 5°F (3°C) above set point
- Minimum Flow** 0.5 gpm (1.9 lpm)
- Maximum Operating Pressure 150psi (1034 kPa)
- Temperature Adjustment Range 90 – 160°F (32 – 71°C)
- Listing/Compliance (Valve Only). ASSE 1017, CSA B125



* The wetted surface of this product contacted by consumable water contains less than one quarter of one percent (0.25%) of lead by weight.
 ** When tested in accordance with ASSE 1017

Capacity ■

Flow Capacity at 50-50 Mixed Ratio							
Pressure Differential							
Valve	C _v	5psi (35 kPa)	10psi (69 kPa)	20psi (138 kPa)	30psi (207 kPa)	45psi (310 kPa)	60psi (414 kPa)
LFLM490	3.42	7.6 gpm (29 lpm)	11.0 gpm (42 lpm)	15.0 gpm (57 lpm)	19.0 gpm (72 lpm)	23.0 gpm (87 lpm)	27.0 gpm (102 lpm)

Dimensions ■

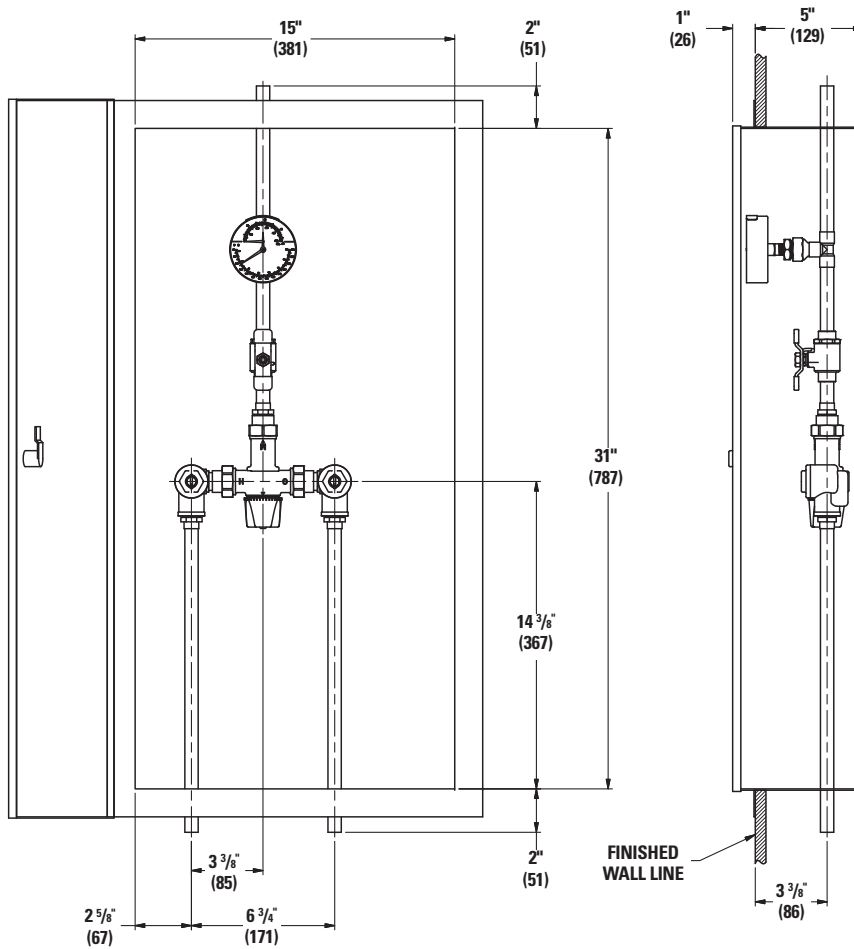

Note:
Dimensions are shown $\pm 1/2''$
Dimensions in parentheses are
in mm

Ordering Information ■

L F L M 4 9 0 E S

Valve	Order Code	View Port	Order Code
23 gpm (87 lpm)	LFLM490	None	0
		Window	W
Finish		Alarm System	
Rough Bronze	A	None	0
Chrome Plated	C		
Piping Inlets/Outlet		Option	
Bottom/Top	E	None	0
		Cold Water Bypass	2
		T/P Gauge on Inlets	4
		C/W Bypass & T/P Gauge on Inlets	6
Cabinet Style		Temperature Range	
Stainless steel, Semi-Recessed	P	90°F - 160°F (32°C - 71°C)	S
Painted, Semi-Recessed	T		

Typical Specification ■

Cabinet Supply Fixture (CSF) shall be factory assembled and tested and include a stainless steel or painted steel cabinet. CSF shall feature a HydroGuard® LFLM490 Series Master-Tempering Valve with advanced paraffin-based actuation technology. The valves shall be constructed using Lead Free* brass. Lead Free* brass valves shall comply with state codes and standards, where applicable, requiring reduced lead content. CSF shall also include copper piping, ball valve(s) and temperature/pressure gauge for diagnostics. The tempering valve shall have union checkstops, an outlet temperature range of 90 – 160°F (32 - 71°C) (with lockable means), and an approach temperature of 5°F (3°C). Valve shall be ASSE 1017 listed and CSA certified. Minimum flow to ASSE 1017 shall be 0.5 gpm (1.9 lpm). Valve shall be a Powers model _____.

Valve shall be a Powers model _____. All alternatives must have written approval prior to bidding.

POWERS™

A Watts Water Technologies Company

ENGINEERING APPROVAL

Project: _____
Contractor: _____
Architect/Engineer: _____



USA: Phone: 1.800.669.5430 • Fax 1.847.229.0526 • www.powerscontrols.com
Canada: Phone: 1.888.208.8927 • Fax 1.888.479.2887 • www.powerscontrols.ca