

Product Specification

LEAD FREE*

Features ■

- Features Lead Free* construction to comply with Lead Free* installation requirements.
- Paraffin-based advanced thermal actuation technology to sense and adjust outlet temperature
- Dirt and lime resistant poppet and seat design
- Virtual shutoff if supply pressure fails
- Vandal-resistant locking mechanism to secure temperature setting
- Factory tested as a complete unit
- Pressure/Temperature Gauges, Ball valves

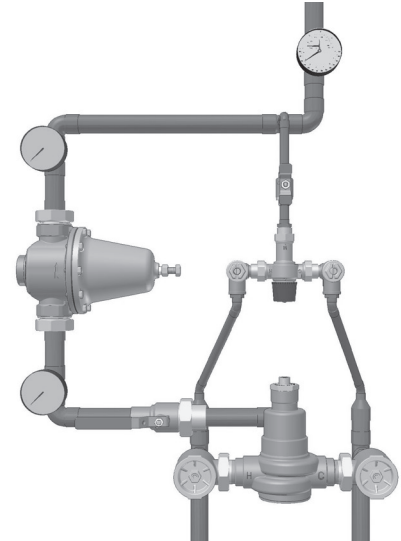

Specifications ■

- Connections See chart on reverse
- Maximum Hot Water Supply Temperature 200°F (93°C)
- Minimum Hot Water Supply Temperature** .. 5°F (3°C) Above Set Point
- Minimum Flow*** 0.5 gpm (1.9 lpm)
- Maximum Operating Pressure 125psi (861 kPa)
- Temperature Adjustment Range**** 90 – 160°F (32 – 71°C)
- Hot Water Inlet Temperature Range 120 – 180°F (49 – 82°C)
- Cold Water Inlet Temperature Range 40 – 80°F (4 – 27°C)
- Listing/Compliance (Valve Only) ASSE 1017, CSA B125



Advanced Thermal Actuation

* The wetted surface of this product contacted by consumable water contains less than one quarter of one percent (0.25%) of lead by weight.

** With Equal Pressure

*** Minimum flow when HiLo valve is installed at or near hot water source w/recirculating tempered water with a properly sized continuously operating recirculating pump.

**** Note: Low limit cannot be less than the cold water temperature. For best operation, hot water should be at least 5°F (3°C) above desired set point.

Capacity ■

Flow Capacity at 50-50 Mixed Ratio								
		Pressure Drop Across Valve						
Model	Min. Flow to ASSE 1017	C _v	5psi (34 kPa)	10psi (69 kPa)	20psi (138 kPa)	30psi (207 kPa)	45psi (310 kPa)	60psi (414 kPa)
LFMM431HL	0.5 gpm 1.89 lpm	9.7	22 gpm 83 lpm	31 gpm 117 lpm	43 gpm 163 lpm	53 gpm 201 lpm	65 gpm 246 lpm	75 gpm 284 lpm
LFMM432HL	0.5 gpm 1.89 lpm	13.0	29 gpm 110 lpm	41 gpm 155 lpm	58 gpm 220 lpm	66 gpm 250 lpm	87 gpm 329 lpm	93 gpm 352 lpm
LFMM433HL	0.5 gpm 1.89 lpm	19.8	44 gpm 167 lpm	63 gpm 238 lpm	86 gpm 326 lpm	108 gpm 409 lpm	133 gpm 503 lpm	153 gpm 579 lpm
LFMM434HL	0.5 gpm 1.89 lpm	24.9	56 gpm 212 lpm	79 gpm 299 lpm	111 gpm 420 lpm	136 gpm 515 lpm	167 gpm 632 lpm	193 gpm 731 lpm
LFMM435HL	3.0 gpm 11.0 lpm	27.7	62 gpm 235 lpm	88 gpm 333 lpm	124 gpm 469 lpm	152 gpm 575 lpm	186 gpm 704 lpm	215 gpm 814 lpm

Dimensions ■

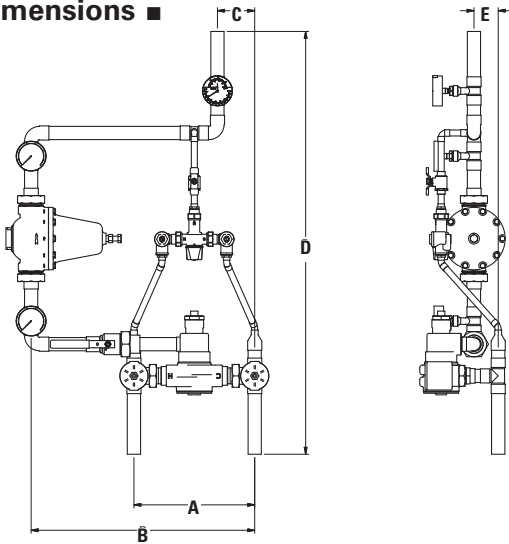

Valve	A	B	C	D	E	Inlets	Outlet
LFMM431HL	9-1/8" (232)	16-3/4" (425)	2-3/4" (70)	37" (940)	2" (51)	3/4" (20)	3/4" (20)
LFMM432HL	9-1/8" (232)	17-1/2" (445)	2-1/2" (64)	37" (940)	2-1/4" (57)	3/4" (20)	1" (25)
LFMM433HL	12-1/2" (318)	23-1/4" (591)	3-7/8" (99)	44" (1118)	2-1/2" (64)	1-1/4" (32)	1-1/4" (32)
LFMM434HL	12-1/2" (318)	26-3/4" (679)	3-1/2" (89)	44-3/4" (1137)	2-3/8" (60)	1-1/4" (32)	1-1/2" (40)
LFMM435HL	12-1/2" (318)	26-3/4" (679)	3-1/2" (89)	47" (1194)	2-3/8" (60)	1-1/4" (32)	1-1/2" (40)

Note:
Dimensions are shown $\pm 1/2''$
Dimensions in parentheses are in mm

Ordering Information ■

Valve	Inlets	Outlet	Order Code
LFLM490/LFMM431	3/4" (20mm)	3/4" (20mm)	LFMM431HL
LFLM490/LFMM432	3/4" (20mm)	1" (25mm)	LFMM432HL
LFLM490/LFMM433	1-1/4" (32mm)	1-1/4" (32mm)	LFMM433HL
LFLM490/LFMM434	1-1/4" (32mm)	1-1/2" (40mm)	LFMM434HL
LFMM431/LFMM434	1-1/4" (32mm)	1-1/2" (40mm)	LFMM435HL

Finish

Rough Bronze
Chrome Plated

Piping

Bottom/Top

Cabinets

Exposed, No Cabinet

Alarm

None

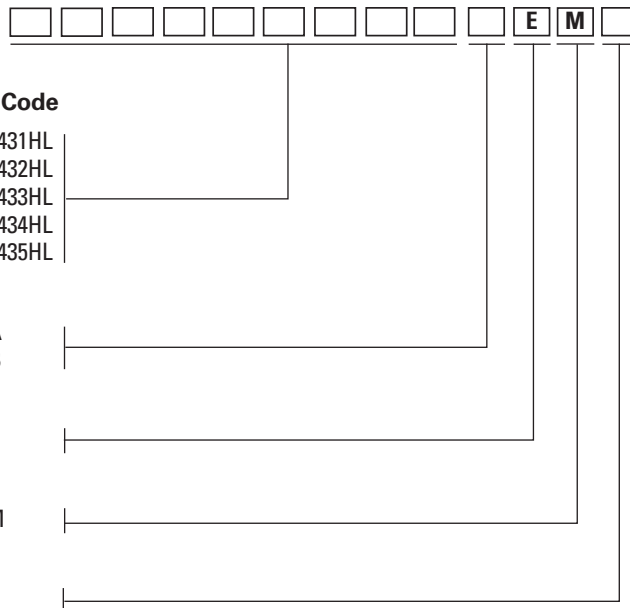

Recirculation Piping Diagram ■

Please see Piping Diagram Section of this catalog.

Typical Specification - Supply Fixtures ■

Hi/Lo Water Temperature Control System shall be factory assembled and tested and shall include two thermostatic mixing valves capable of maintaining water temperature to 5°F (3°C) above set point. Hi/Lo shall include HydroGuard® XP LFMM430 and/or LFLM490 Series Master-Tempering Valve with advanced, paraffin-based actuation technology. The valves shall be constructed using Lead Free* brass. Lead Free* brass valves shall comply with state codes and standards, where applicable, requiring reduced lead content. Hi/Lo shall also include copper piping, ball valve(s) and temperature/pressure gauge for diagnostics. The tempering valve shall have union checkstops, an outlet temperature range of 90 – 160°F (32 – 71°C) (with lockable means), and a single seat design for positive shutoff. Valve shall be ASSE 1017 listed and CSA certified. Minimum flows to ASSE 1017 shall be 0.5 gpm (1.9 lpm) for LFMM431HL, LFMM432HL, LFMM433HL, LFMM434HL, and 3.0 gpm (11 lpm) for LFMM435HL. Valve shall be a Powers' Model _____. All alternatives must have written approval prior to bidding.

ENGINEERING APPROVAL

Project: _____
Contractor: _____
Architect/Engineer: _____

POWERS™

A Watts Water Technologies Company



ISO 9001-2000
CERTIFIED

USA: Phone: 1.800.669.5430 • Fax 1.847.229.0526 • www.powerscontrols.com
Canada: Phone: 1.888.208.8927 • Fax 1.888.479.2887 • www.powerscontrols.ca