

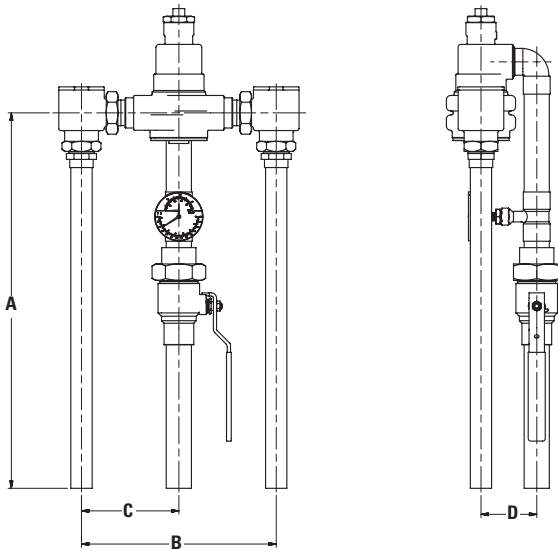

## Dimensions ■



Valve	A	B	C	D
LFMM431	16-3/4" (425)	9-1/8" (232)	4-1/2" (114)	2-5/8" (67)
LFMM432	16-3/4" (425)	9-1/8" (232)	4-1/2" (114)	2-3/4" (70)
LFMM433	24-1/4" (616)	12-5/8" (321)	6-1/4" (159)	3-3/8" (86)
LFMM434	24-1/4" (616)	12-5/8" (321)	6-1/4" (159)	3-5/8" (92)
LFMM435	27" (686)	15-5/8" (397)	7-7/8" (200)	4-1/4" (108)

Valve	Inlets NPT	Outlet NPT
LFMM431	3/4" (20)	3/4" (20)
LFMM432	3/4" (20)	1" (25)
LFMM433	1-1/4" (32)	1-1/4" (32)
LFMM434	1-1/4" (32)	1-1/2" (40)
LFMM435	2" (50)	2" (50)

Note:  
Dimensions are shown  $\pm 1/2''$   
Dimensions in parentheses are in mm

## Ordering Information ■



### Valve

42 gpm (159 lpm)  
64 gpm (242 lpm)  
110 gpm (416 lpm)  
144 gpm (545 lpm)  
208 gpm (787 lpm)

### Order Code

LFMM431  
LFMM432  
LFMM433  
LFMM434  
LFMM435

### Finish

Rough Bronze  
Chrome Plated

A  
C

### Piping Inlets/Outlet

Bottom/Bottom

F

### Cabinet Style

None

M

### Alarm System

None

### Option

None  
Cold Water Bypass  
T/P Gauge on Inlets  
C/W Bypass & T/P Gauge on Inlets

### Motor Range

90°F - 160°F (32°C - 71°C)  
60°F - 90°F (16°C - 32°C)

### Order Code

0

0

2

4

6

S

W

## Recirculation Piping Diagram ■

Please see Piping Diagram Section of this catalog.

## Typical Specification - Supply Fixtures (MM) ■

Supply Fixture shall be factory assembled and tested and feature a HydroGuard® XP LFMM430 series master-tempering valve with advanced, paraffin-based actuation technology. Supply fixture shall also include copper piping, ball valve(s) and temperature/pressure gauge for diagnostics. The tempering valve shall have union checkstops, an outlet temperature range of 90 – 160°F (32° – 71°C) (with lockable means), a single seat design for positive shutoff and an approach temperature 5°F (3°C). The valves shall be constructed using Lead Free\* brass. Lead Free\* brass valves shall comply with state codes and standards, where applicable, requiring reduced lead content. Valve shall be ASSE 1017 listed and CSA certified. Minimum flows to ASSE 1017 shall be LFMM431 (3.0 gpm, 11 lpm), LFMM432 (4.0 gpm, 15 lpm), LFMM433 (5.0 gpm, 19 lpm), LFMM434 (7.0 gpm, 26 lpm), LFMM435 (10.0 gpm, 38 lpm).

Valve shall be a Powers Model \_\_\_\_\_. All alternatives must have written approval prior to bidding.

# POWERS™

A Watts Water Technologies Company

## ENGINEERING APPROVAL

Project: \_\_\_\_\_

Contractor: \_\_\_\_\_

Architect/Engineer: \_\_\_\_\_



ISO 9001-2000  
CERTIFIED

USA: Phone: 1.800.669.5430 • Fax 1.847.229.0526 • www.powerscontrols.com  
Canada: Phone: 1.888.208.8927 • Fax 1.888.479.2887 • www.powerscontrols.ca