

**HYDROGUARD® XP Master Tempering Valves Supply Fixture  
Series LFMM430 Bottom Inlets/Bottom Outlet – Semi-Recessed Cabinet**

**Product Specification**

**LEAD FREE\***

**Features ■**

- Features Lead Free\* construction to comply with Lead Free\* installation requirements.
- Paraffin-based advanced thermal actuation technology to sense and adjust outlet temperature
- Dirt and lime resistant poppet and seat design
- Virtual shutoff if supply pressure fails
- Vandal-resistant locking mechanism to secure temperature setting
- Stainless steel or white painted cabinets
- Factory tested valve and piping
- Rotatable union triple-duty checkstops with filters, dial-thermometer, ball valve
- Rough bronze and chrome finishes

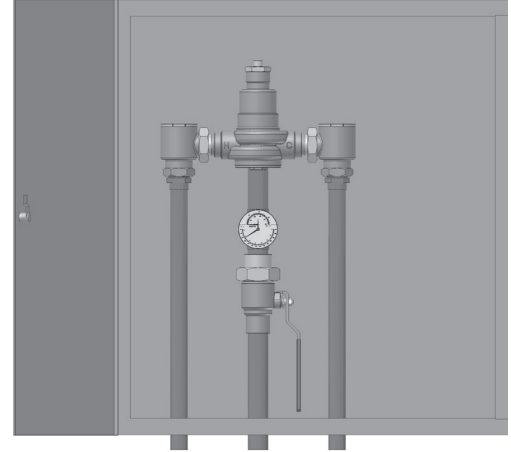

Advanced Thermal Activation

**Specifications ■**

- Connections . . . . . See chart on reverse
- Maximum Hot Water Supply Temperature . . . . 200°F (93°C)
- Minimum Hot Water Supply Temperature\*\* . . 5°F (3°C) Above Set Point
- Minimum Flow\*\*\* . . . . . 0.5 gpm (1.9 lpm)
- Maximum Operating Pressure . . . . . 125psi (861 kPa)
- Temperature Adjustment Range\*\*\*\* . . . . . Standard 90 – 160°F (32 – 71°C)  
Low 60 – 90°F (16 – 32°C)
- Hot Water Inlet Temperature Range . . . . . 120 – 180°F (49 – 82°C)
- Cold Water Inlet Temperature Range . . . . . 40 – 80°F (4 – 27°C)
- Listing/Compliance–Valve Only . . . . . ASSE 1017, CSA B125

\* The wetted surface of this product contacted by consumable water contains less than one quarter of one percent (0.25%) of lead by weight.

\*\* With equal pressure

\*\*\* Minimum flow when the valve is installed at or near hot water source w/recirculated tempered water with a properly sized continuously operating recirculating pump

\*\*\*\* Note: Low limit cannot be less than the cold water temperature. For best operation, hot water should be at least 5°F (3°C) above desired set point.

**Capacity ■**

Flow Capacity at 50-50 Mixed Ratio								
		Pressure Drop Across Valve						
Model	Min. Flow to ASSE 1017	C <sub>v</sub>	5psi (34 kPa)	10psi (69 kPa)	20psi (69 kPa)	30psi (207 kPa)	45psi (310 kPa)	60psi (414 kPa)
LFMM431	3 gpm 11 lpm	6.32	14 gpm 53 lpm	20 gpm 76 lpm	28 gpm 106 lpm	35 gpm 132 lpm	42 gpm 159 lpm	49 gpm 185 lpm
LFMM432	4 gpm 15 lpm	9.49	21 gpm 80 lpm	30 gpm 114 lpm	42 gpm 159 lpm	52 gpm 197 lpm	64 gpm 242 lpm	74 gpm 280 lpm
LFMM433	5 gpm 19 lpm	16.44	37 gpm 140 lpm	52 gpm 197 lpm	74 gpm 280 lpm	90 gpm 341 lpm	110 gpm 416 lpm	127 gpm 481 lpm
LFMM434	7 gpm 26 lpm	21.50	48 gpm 182 lpm	68 gpm 257 lpm	96 gpm 363 lpm	118 gpm 447 lpm	144 gpm 545 lpm	167 gpm 632 lpm
LFMM435	10 gpm 38 lpm	31.00	69 gpm 261 lpm	98 gpm 371 lpm	139 gpm 526 lpm	170 gpm 644 lpm	208 gpm 787 lpm	240 gpm 908 lpm

## Dimensions ■

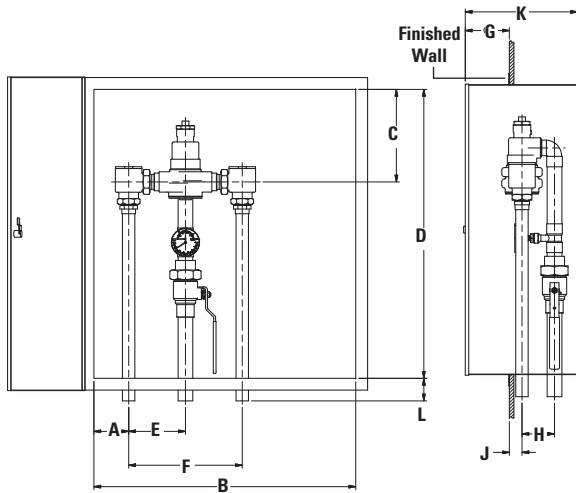

Valve	A	B	C	D	E	F	G	H	J	K	L
LFMM431	3-1/2"	20"	9-1/4"	24"	4-5/8"	9-1/4"	3-1/2"	2-5/8"	1-1/8"	9"	2"
	(89)	(508)	(235)	(610)	(117)	(235)	(89)	(67)	(29)	(229)	(50)
LFMM432	3-1/2"	20"	9-1/4"	24"	4-5/8"	9-1/4"	3-1/2"	2-3/4"	1-1/8"	9"	2"
	(89)	(508)	(235)	(610)	(117)	(235)	(89)	(70)	(29)	(229)	(50)
LFMM433	3-7/8"	29"	10-1/4"	32"	6-1/4"	12-1/2"	4-1/2"	3-3/8"	1-3/8"	12"	2-1/2"
	(98)	(737)	(260)	(813)	(159)	(318)	(114)	(86)	(35)	(305)	(64)
LFMM434	3-7/8"	29"	10-1/4"	32"	6-1/4"	12-1/2"	4-1/2"	3-5/8"	1-3/8"	12"	2-1/2"
	(98)	(737)	(260)	(813)	(159)	(318)	(114)	(92)	(35)	(305)	(64)
LFMM435	4-1/8"	38"	13-5/8"	38"	7-7/8"	15-3/4"	4"	4-1/4"	2"	13"	2-1/2"
	(105)	(965)	(346)	(965)	(200)	(400)	(102)	(108)	(50)	(330)	(64)

Valve	Inlets	Outlet
LFMM431	3/4" (20)	3/4" (20)
LFMM432	3/4" (20)	1" (25)
LFMM433	1-1/4" (32)	1-1/4" (32)
LFMM434	1-1/4" (32)	1-1/2" (40)
LFMM435	2" (50)	2" (50)

Note:  
Dimensions are shown  $\pm 1/2''$   
Dimensions in parentheses are in mm

## Ordering Information ■

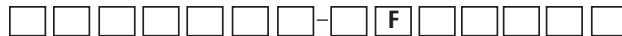

### Valve

42 gpm (159 lpm)	LFMM431
64 gpm (242 lpm)	LFMM432
110 gpm (416 lpm)	LFMM433
144 gpm (545 lpm)	LFMM434
208 gpm (787 lpm)	LFMM435

### Finish

Rough Bronze	A
Chrome Plated	C

### Piping Inlets/Outlet

Bottom/Bottom	F
---------------	---

### Cabinet Style

Stainless Steel, Semi-Recessed	P
Painted, Semi-Recessed	T

### View Port

None	0
Window	W

### Alarm System

None	0
------	---

### Option

None	0
Cold Water Bypass	2
T/P Gauge on Inlets	4
C/W Bypass & T/P Gauge on Inlets	6

### Motor Range

90°F - 160°F (32°C - 71°C)	S
60°F - 90°F (16°C - 32°C)	W

## Recirculation Piping Diagram ■

Please see Piping Diagram Section of this catalog.

## Typical Specification - Supply Fixtures ■

Cabinet Supply Fixture (CSF) shall be factory assembled and tested and include a stainless steel or painted steel cabinet. CSF shall feature a HydroGuard® XP LFMM430 series master-tempering valve with advanced paraffin-based actuation technology. The valves shall be constructed using Lead Free\* brass. Lead Free\* brass valves shall comply with state codes and standards, where applicable, requiring reduced lead content. CSF shall also include copper piping, ball valve(s) and temperature/pressure gauge for diagnostics. The tempering valve shall have union checkstops, an outlet temperature range of 90 – 160°F (32 – 71°C) (with lockable means), a single seat design for positive shutoff and an approach temperature of 5°F (3°C). Valve shall be ASSE 1017 listed and CSA certified. Minimum flows to ASSE 1017 shall be LFMM431 (3.0 gpm, 11 lpm), LFMM432 (4.0 gpm, 15 lpm), LFMM433 (5.0 gpm, 19 lpm), LFMM434 (7.0 gpm, 26 lpm), LFMM435 (10.0 gpm, 38 lpm).

Valve shall be a Powers model \_\_\_\_\_. All alternatives must have written approval prior to bidding.

## ENGINEERING APPROVAL

Project: \_\_\_\_\_  
Contractor: \_\_\_\_\_  
Architect/Engineer: \_\_\_\_\_



# POWERS™

A Watts Water Technologies Company

USA: Phone: 1.800.669.5430 • Fax 1.847.229.0526 • www.powerscontrols.com  
Canada: Phone: 1.888.208.8927 • Fax 1.888.479.2887 • www.powerscontrols.ca