

**HYDROGUARD® XP Hi/Lo Master Tempering Valves
Supply Fixture Series LFSH1430
Bottom Inlets/Side Outlet – Exposed**

Product Specification

LEAD FREE*

Features ■

- Features Lead Free* construction to comply with Lead Free* installation requirements.
- Paraffin-based advanced thermal actuation technology to sense and adjust outlet temperature
- Dirt and lime resistant poppet and seat design
- Virtual shutoff if supply pressure fails
- Vandal-resistant locking mechanism to secure temperature setting
- Factory tested valve and piping
- Rotatable union triple-duty checkstops with filters, dial-thermometer, ball valve
- Rough bronze and chrome finishes

Specifications ■

Connections See chart on reverse

Maximum Hot Water Supply Temperature ... 200°F (93°C)

Minimum Hot Water Supply Temperature** .. 5°F (3°C) above set point

Minimum Flow*** 0.5 gpm (1.9 lpm)

Maximum Operating Pressure 125psi (861 kPa)

Temperature Adjustment Range**** Standard 90 – 160°F (32 – 71°C)
Low 60 – 90°F (16 – 32°C)

Hot Water Inlet Temperature Range 120 – 180°F (49 – 82°C)

Cold Water Inlet Temperature Range 40 – 80°F (4 – 27°C)

Listing/Compliance–Valve Only ASSE 1017, CSA B125

* The wetted surface of this product contacted by consumable water contains less than one quarter of one percent (0.25%) of lead by weight.

** With equal pressure

*** Minimum flow when the valve is installed at or near hot water source w/recirculated tempered water with a properly sized continuously operating recirculating pump

**** Note: Low limit cannot be less than the cold water temperature. For best operation, hot water should be at least 5°F (3°C) above desired set point.

Capacity ■

Flow Capacity at 50-50 Mixed Ratio								
Model	Min. Flow to ASSE 1017	C _v	Pressure Drop Across Valve					
			5psi (34 kPa)	10psi (69 kPa)	20psi (138 kPa)	30psi (207 kPa)	45psi (310 kPa)	60psi (414 kPa)
LFSH1432	1 gpm	8.54	19 gpm	27 gpm	38 gpm	47 gpm	57 gpm	66 gpm
	4 lpm		72 lpm	102 lpm	144 lpm	178 lpm	216 lpm	250 lpm
LFSH1434	1 gpm	19.00	42 gpm	60 gpm	85 gpm	104 gpm	127 gpm	147 gpm
	4 lpm		159 lpm	227 lpm	322 lpm	394 lpm	481 lpm	556 lpm
LFSH1435	5 gpm	30.00	67 gpm	95 gpm	134 gpm	164 gpm	201 gpm	232 gpm
	19 lpm		254 lpm	360 lpm	507 lpm	621 lpm	761 lpm	878 lpm

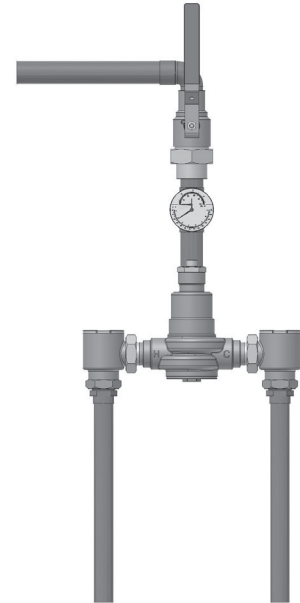

Advanced Thermal Activation

Dimensions ■

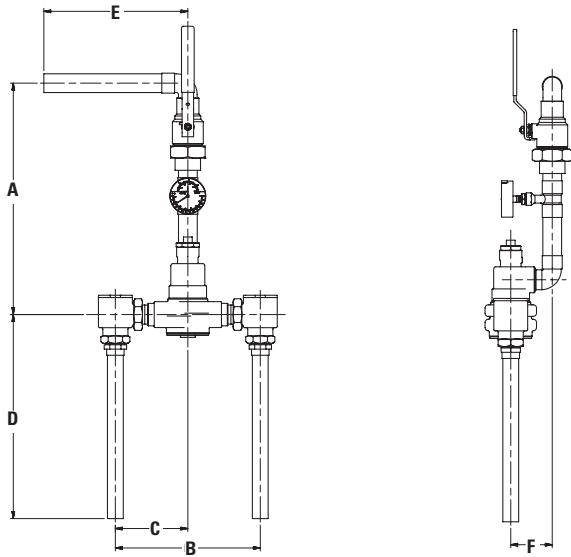

Valve	A	B	C	D	E	F
LFSH1432	17" (432)	9-1/8" (232)	4-1/2" (114)	16-3/4" (425)	10-1/2" (267)	2-3/4" (70)
LFSH1434	20-1/16" (510)	12-5/8" (321)	6-1/4" (159)	17-3/4" (451)	12-1/2" (318)	3-5/8" (92)
LFSH1435	25-3/4" (654)	15-5/8" (397)	7-7/8" (200)	22-5/8" (575)	14-1/2" (368)	4-1/4" (108)

Note:
Dimensions are shown $\pm 1/2''$
Dimensions in parentheses are in mm

Valve	Inlets	Outlet
LFSH1432	3/4" (20)	1" (25)
LFSH1434	1-1/4" (32)	1-1/2" (40)
LFSH1435	2" (50)	2" (50)

Ordering Information ■



Valve

57 gpm (216 lpm)
127 gpm (481 lpm)
201 gpm (761 lpm)

Order Code

LFSH1432
LFSH1434
LFSH1435

Alarm System

None

Order Code

0

Finish

Rough Bronze
Chrome Plated

A
C

Option

None
Cold Water Bypass
T/P Gauge on Inlets
C/W Bypass & T/P Gauge on Inlets

0
2
4
6

Piping Inlets/Outlet

Bottom/Side

G

Temperature Range

90°F - 160°F (32°C - 71°C)
60°F - 90°F (16°C - 32°C)

S
W

Cabinet Style

None

M

Recirculation Piping Diagram ■

Please see Piping Diagram Section of this catalog.

Typical Specification - Supply Fixtures ■

Supply Fixture shall be factory assembled and tested and feature a HydroGuard® XP LFSH1430 Series Single-Valve Hi/Lo with advanced, paraffin-based actuation technology. The valves shall be constructed using Lead Free* brass. Lead Free* brass valves shall comply with state codes and standards, where applicable, requiring reduced lead content. Supply Fixture shall also include copper piping, ball valve(s) and temperature/pressure gauge for diagnostics. The tempering valve shall have union check stops, an outlet temperature range of 90 – 160°F (32 - 71°C) (with lockable means), a single seat design for positive shutoff and an approach temperature of 5°F (3°C). Valve shall be ASSE 1017 listed and CSA certified. Minimum flows to ASSE 1017 shall be LFSH1432 (1.0 gpm, 4 lpm), LFSH1434 (1.0 gpm, 4 lpm), LFSH1435 (5.0 gpm, 19 lpm).

Valve shall be a Powers' model _____. All alternatives must have written approval prior to bidding.

ENGINEERING APPROVAL

Project: _____
Contractor: _____
Architect/Engineer: _____



POWERS™

A Watts Water Technologies Company

USA: Phone: 1.800.669.5430 • Fax 1.847.229.0526 • www.powerscontrols.com
Canada: Phone: 1.888.208.8927 • Fax 1.888.479.2887 • www.powerscontrols.ca