

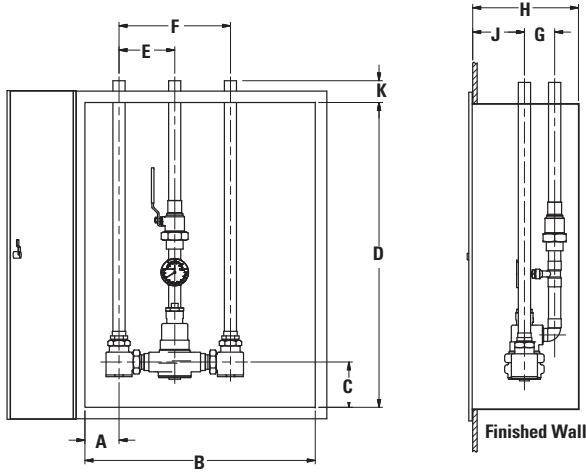

## Dimensions ■



| Valve    | A      | B     | C      | D       | E      | F       | G      | H     | J      | K      |
|----------|--------|-------|--------|---------|--------|---------|--------|-------|--------|--------|
| LFSH1432 | 3-7/8" | 20"   | 4-3/4" | 26"     | 4-5/8" | 9-1/4"  | 2-3/4" | 9"    | 4-1/2" | 2"     |
|          | (98)   | (508) | (121)  | (660)   | (117)  | (235)   | (70)   | (229) | (114)  | (50)   |
| LFSH1434 | 3-7/8" | 26"   | 4-3/4" | 34-1/2" | 6-1/4" | 12-1/2" | 3-5/8" | 12"   | 5-7/8" | 2-1/2" |
|          | (98)   | (660) | (120)  | (876)   | (159)  | (318)   | (92)   | (305) | (149)  | (64)   |
| LFSH1435 | 4-1/2" | 32"   | 6-3/8" | 42"     | 7-7/8" | 15-5/8" | 4-1/4" | 13"   | 6"     | 2-1/2" |
|          | (114)  | (813) | (162)  | (1067)  | (200)  | (397)   | (108)  | (330) | (152)  | (64)   |

Note:  
Dimensions are shown  $\pm 1/2''$   
Dimensions in parentheses are in mm

| Valve    | Inlets         | Outlet         |
|----------|----------------|----------------|
| LFSH1432 | 3/4"<br>(20)   | 1"<br>(25)     |
| LFSH1434 | 1-1/4"<br>(32) | 1-1/2"<br>(40) |
| LFSH1435 | 2"<br>(50)     | 2"<br>(50)     |

## Ordering Information ■



### Valve

57 gpm (216 lpm)  
127 gpm (481 lpm)  
201 gpm (761 lpm)

### Order Code

LFSH1432  
LFSH1434  
LFSH1435

### Finish

Rough Bronze  
Chrome Plated

A  
C

### Piping Inlets/Outlet

Top/Top

D

### Cabinet Style

Stainless Steel, Recessed  
Painted, Recessed

N  
R

### View Port

None  
Window

### Order Code

0  
W

### Alarm System

None

0

### Option

None  
Cold Water Bypass  
T/P Gauge on Inlets  
C/W Bypass & T/P Gauge on Inlets

0  
2  
4  
6

### Temperature Range

90°F - 160°F (32°C - 71°C)  
60°F - 90°F (16°C - 32°C)

S  
W

## Recirculation Piping Diagram ■

Please see Piping Diagram Section of this catalog.

## Typical Specification ■

Cabinet Supply Fixture (CSF) shall be factory assembled and tested and include a stainless steel or painted steel cabinet. CSF shall feature a HydroGuard® XP LFSH1430 series single-valve hi/lo with advanced paraffin-based actuation technology. The valves shall be constructed using Lead Free\* brass. Lead Free\* brass valves shall comply with state codes and standards, where applicable, requiring reduced lead content. CSF shall also include copper piping, ball valve(s) and temperature/pressure gauge for diagnostics. The tempering valve shall have union check stops, an outlet temperature range of 90 – 160°F (32° - 71°C) (with lockable means), a single seat design for positive shutoff and an approach temperature of 5°F (3°C). Minimum flows to ASSE 1017 shall be LFSH1432 (1.0 gpm, 4 lpm), LFSH1434 (1.0 gpm, 4 lpm), LFSH1435 (5.0 gpm, 191 lpm).

Valve shall be a Powers model \_\_\_\_\_. All alternatives must have written approval prior to bidding.

### ENGINEERING APPROVAL

Project: \_\_\_\_\_  
Contractor: \_\_\_\_\_  
Architect/Engineer: \_\_\_\_\_

# POWERS™

A Watts Water Technologies Company



ISO 9001-2000  
CERTIFIED

USA: Phone: 1.800.669.5430 • Fax 1.847.229.0526 • www.powerscontrols.com  
Canada: Phone: 1.888.208.8927 • Fax 1.888.479.2887 • www.powerscontrols.ca