

**Product Specification**

**Features ■**

- Valve utilizes paraffin-based advanced thermal actuation technology to sense and adjust outlet temperature
- Dirt and lime resistant poppet and seat design
- Virtual shutoff if supply pressure fails
- Vandal-resistant locking mechanism to secure temperature setting
- Factory tested
- Rotatable union triple-duty checkstops
- Rough bronze and chrome finishes

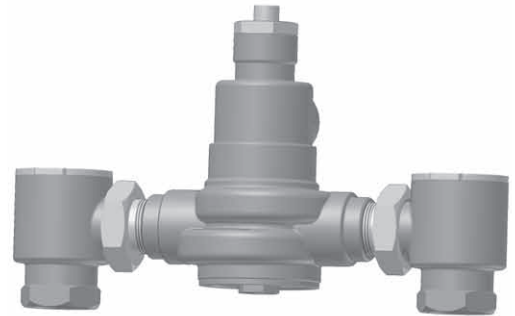

Advanced Thermal Activation

**Specifications ■**

- Connections..... See chart on reverse
- Maximum Hot Water Supply Temperature ... 200°F (93°C)
- Minimum Hot Water Supply Temperature ... 5°F (3°C) above set point\*
- Minimum Flow\*\* ..... 0.5 gpm (1.9 lpm)
- Maximum Operating Pressure ..... 125 psi (861 kPa)
- Temperature Adjustment Range ..... Standard 90 – 160°F (32 – 71°C)  
Low 60 – 90°F (16 – 32°C)
- Hot Water Inlet Temperature Range ..... 120 – 180°F (49 – 82°C)
- Cold Water Inlet Temperature Range ..... 40 – 80°F (4 – 27°C)
- Listing/Compliance ..... ASSE 1017, CSA B125

\* With equal pressure

\*\* Minimum flow when the valve is installed at or near hot water source w/recirculated tempered water with a properly sized continuously operating recirculating pump

**Capacity ■**

Flow Capacity at 50-50 Mixed Ratio									
		Pressure Drop Across Valve							
Model	Min. Flow to ASSE 1017	Cv	5psi (34 kPa)	10psi (69 kPa)	20psi (138 kPa)	30psi (207 kPa)	45psi (310 kPa)	60psi (414 kPa)	70psi (517 kPa)
SH1432	1 gpm 4 lpm	8.54	19 gpm 72 lpm	27 gpm 102 lpm	38 gpm 144 lpm	47 gpm 178 lpm	57 gpm 216 lpm	66 gpm 250 lpm	71 gpm 269 lpm
SH1434	1 gpm 4 lpm	19.00	42 gpm 159 lpm	60 gpm 227 lpm	85 gpm 322 lpm	104 gpm 394 lpm	127 gpm 481 lpm	147 gpm 556 lpm	159 gpm 602 lpm
SH1435	5 gpm 19 lpm	30.00	67 gpm 254 lpm	95 gpm 341 lpm	134 gpm 507 lpm	164 gpm 621 lpm	201 gpm 761 lpm	232 gpm 878 lpm	251 gpm 950 lpm

## Dimensions ■

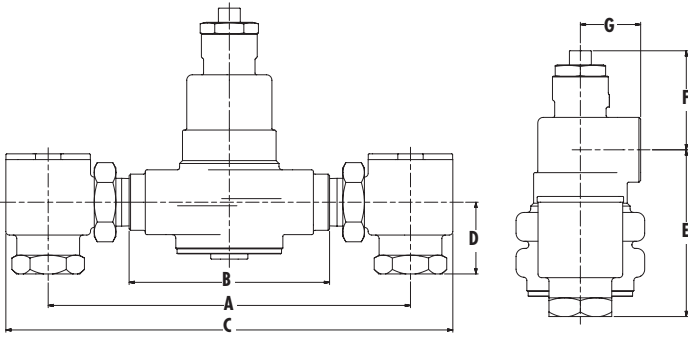

Valve	A	B	C	D	E	F	G
SH1432	9-1/8"	4-3/4"	11-3/8"	1-7/8"	4"	3-1/4"	1-5/8"
	(232)	(121)	(289)	(48)	(102)	(83)	(41)
SH1434	12-5/8"	7"	15-1/2"	2-1/2"	5-3/4"	3-1/2"	2-1/16"
	(321)	(178)	(394)	(64)	(146)	(89)	(52)
SH1435	15-5/8"	7-1/8"	19-1/4"	2-3/4"	7-7/8"	4-3/8"	2-3/8"
	(397)	(181)	(489)	(70)	(200)	(111)	(60)

Valve	Inlets NPT	Outlet NPT
SH1432	3/4"	1"
SH1434	1-1/4"	1-1/2"
SH1435	2"	2"

Note:  
Dimensions are shown  $\pm 1/4"$   
Dimensions in brackets are in mm.

## Ordering Information ■



Valve	Order Code
57 gpm (216 lpm)	SH1432
127 gpm (481 lpm)	SH1434
201 gpm (761 lpm)	SH1435

### Finish/Temperature Range

Rough Bronze, Standard	1
Chrome Plated, Standard	2
Rough Bronze, Low	3
Rough Bronze, Low	4

### Temperature/Pressure Gauge on Outlet

None	0
For SH1432, Rough Bronze	1
For SH1432, Chrome Plated	2
For SH1434, Rough Bronze	3
For SH1434, Chrome Plated	4
For SH1435, Rough Bronze	5
For SH1435, Chrome Plated	6

## Recirculation Piping Diagram ■

Please see Piping Diagram Section of this catalog.

## Typical Specification ■

Single-valve Hi/Lo shall feature paraffin-based, thermal actuation technology for precise temperature control. Valve shall be listed to ASSE 1017 and CSA B125 and have an approach temperature of 5°F (3°C). Valve shall have an outlet temperature range from 90° – 160°F (32 – 71°C) with a lockable temperature-setting feature. Valve shall be manufactured of corrosion resistant materials and feature a single-seat design for positive shutoff. Valves shall come standard with union check stops. Minimum flows to ASSE 1017 shall be SH1432 (1.0 gpm) (4 Lpm), SH1434 (1.0 gpm) (4 Lpm), SH1435 (5.0 gpm) (19 Lpm).

Single-valve Hi/Lo shall be of Powers Series SH1430. Any alternate must have a written approval prior to bidding.

### ENGINEERING APPROVAL

Project: \_\_\_\_\_  
Contractor: \_\_\_\_\_  
Architect/Engineer: \_\_\_\_\_

# POWERS™

A Watts Water Technologies Company

ES-P-SH1430 1011



**ISO 9001-2000  
CERTIFIED**

USA: Phone: 1.800.669.5430 • Fax 1.847.229.0526 • www.powerscontrols.com

Canada: Phone: 1.888.208.8927 • Fax 1.888.882.1979 • www.powerscontrols.ca

© 2010 Powers