

Series 20 Dual Check Backflow Preventers



EXCELLENCE MATTERS – SPECIFY IT!

A Division of Watts Regulator Company

1427 North Market Blvd • Suite #9 • Sacramento, CA 95834 • Phone: 916-928-0123 • Fax: 916-928-9333

www.amesfirewater.com



■ Protecting the Public Water Supply

Both public water supply officials and consumers need to protect the public supply of safe drinking water. As a public water supply professional, you need to do everything in your power to prevent the reverse flow associated with:

- Main line flushing (maintenance)
- Firefighting (emergency)
- Main line rupture or blowout (disaster)

Such activities and occurrences can siphon domestic water systems, drawing every conceivable fluid connected to the user's system back into the public water supply.

Series 20 Backflow Preventers provide cost-effective backflow protection of the public water supply when used according to the local or state plumbing code requirements. As part of your comprehensive containment program, you should require the installation of a Series 20 unit as a condition for the user to receive service from the public water system.

■ This three-step program should ideally include:

The first line of defense

The user certifies that his/her domestic water system complies with the local plumbing codes.

The second line of defense

The user installs a dual check backflow preventer at the water meter as prescribed by the supplier of safe drinking water.

The third line of defense – education

The supplier of water provides educational material that teaches the user how to avoid contaminating or polluting the drinking water once it has entered his domestic water system.

■ Series 20 Dual Check Backflow Preventers from Ames

To ensure the safety of drinking water, there can be no room for compromise. That's why Ames provides the incomparable Series 20 Backflow Preventers with dual check security. Installed at the residential water meter or service entrance, Series 20 Backflow Preventers offer:

- Low pressure drop
- Easy maintenance and service
- Wide selection of types, sizes, and connections

Our unique check modules put our Series 20 Backflow Preventers distinctly ahead of other residential containment devices. With their innovative design, most Series 20 models offer a full range of features, including:

- Chloramine resistance – for long life under the harshest water conditions
- Complete modularity – for easy maintenance
- Limit stops – to prevent damage from thermal expansion
- Center and edge guides – to ensure repeatable seating and minimize localized wear
- No exposed screws or threads – to eliminate corrosion potential and improve serviceability

Of course, Series 20 Dual Check Backflow Preventers embody the quality engineering of Ames, a world leader in valve technology. And you have the confidence of knowing the Series 20 are ASSE 1024 Certified. So when you need to be sure you have the most reliable residential containment products, specify Ames Series 20 backflow preventers.

Features	Model/Series			
	20	L20	20S	Cu20
Center Stem Guides	•	•	•	•
Edge Guides	•		•	•
Chloramine Resistant Components	•	•	•	•
Modular Design	•		•	•
Limit Stops	•	•	•	•
Stainless Steel Springs	•	•	•	•
Replaceable Seats	•		•	•
No Exposed Screws Or Threads	•	•	•	•

Series 20 Check Module

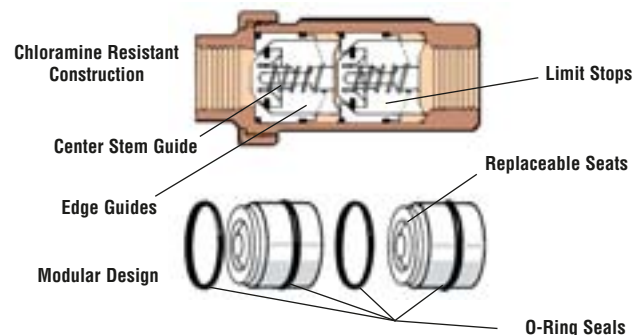

Series 20

Dual Check Backflow Preventers

Sizes: 1/2" – 1 1/4" (15 – 32mm)

Available with an extensive combination of inlet/outlet sizes, types of thread, and end connections—including retrofit compression fittings and hose connections—the Series 20 can be installed in a variety of piping configurations, and in conjunction with a wide range of meter horns, copper setters, and meter boxes.

Description

The straight line, poppet-type construction of the Series 20 minimizes pressure drop and provides smooth flow characteristics. It can be installed horizontally or vertically. It is not adversely affected by normal line pressure surges, will not cause water hammer, and operates without chatter or vibration.

Standards

Tested and certified to meet ANSI/ASSE Standard 1024.

Important: Inquire with governing authorities for local installation requirements.



Specifications

The dual check backflow preventer shall meet the domestic requirements of ANSI/ASSE Standard 1024, and bear the seal of approval. It shall be bronze-bodied and include not less than one union, with the union nut drilled to accept a tamper-proofing lock wire. A brass identification tag indicating direction of flow shall be securely attached to the valve body by corrosion-resistant mechanical fasteners. The dual check shall be an Ames Fire & Waterworks Series 20. (Please select the model best suited to your application.)

Materials

Cast bronze body, durable plastic check modules, injection molded of acetyl resin and PPO, silicone discs and Buna 'N' seals, stainless steel springs, one union and O-ring union seal.

Product Availabilities

Series 20: Inlet/Outlet Connections – Types available, ordering code, sizes available.

Connection Type	Connection Code	Sizes Available	
		inches	mm
National Pipe Thread Female	2	1/2, 3/4, 1	15, 20, 25
National Pipe Thread Male	3	1/2, 3/4, 1, 1 1/4	15, 20, 25, 32
Meter Thread Female*	4	3/4, 1, 1 1/4	20, 25, 32
Meter Thread Male*	5	3/4, 1, 1 1/4	20, 25, 32
Pack Joint Female	6	3/4, 1	20, 25
Pack Joint Male	7	3/4, 1	20, 25
Female Solder	8	3/4, 1	20, 25
Male Solder	9	3/4, 1	20, 25
Female Meter Thread (Swivel)	10	3/4, 1, 1 1/4	20, 25, 32
Male Hose Thread	11	3/4	20
Female Hose Thread	12	3/4	20
Male Meter Yoke Thread	13	3/4	20
PEX	15	1/2, 3/4, 1	15, 20, 25
CPVC	16	1/2, 3/4, 1	15, 20, 25

*See "How To Order" on pages 7.

Union (U) Connections available on all inlet/outlet types and sizes.

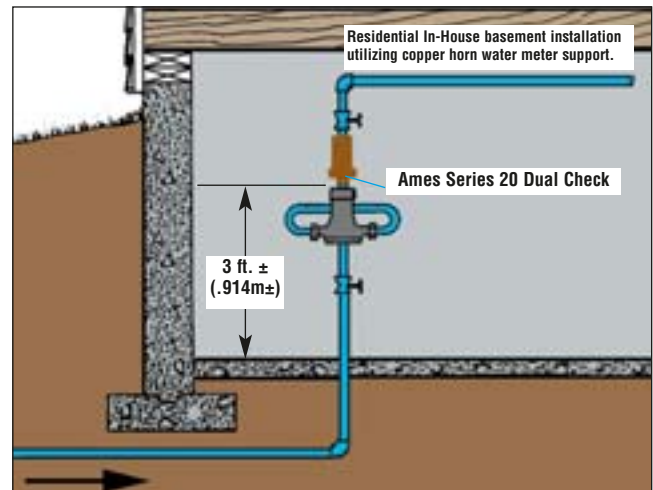
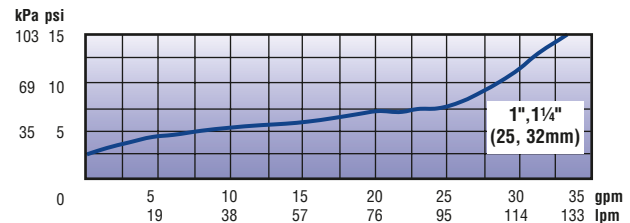
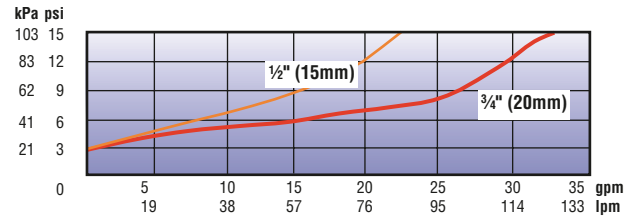

Pressure / Temperature

Maximum Pressure: 150psi (10 bar).

Working Temperature: 33°F – 140°F sustained; intermittent to 180°F (0.6°C – 60°C sustained; intermittent to 82.2°C)

Dimensions / Weight

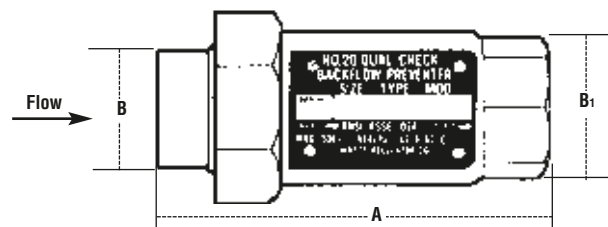

A		B		B1		Weight	
in.	mm	in.	mm	in.	mm	lbs.	kgs.
4 3/8	110	2 5/16	58	1 3/4	44	1.75	.79

Series L20

In-Line Testable/Serviceable Dual Check Backflow Preventers

Sizes: 3/4" and 1" (20 and 25mm)

Description

The ideal solution for residential containment applications that require in-line testable and serviceable dual check backflow preventers.

Standards

Tested and certified to meet ANSI/ASSE Standard 1024.



Important: Inquire with governing authorities for local installation requirements.

Specifications

The dual check backflow preventer shall be designed under the ASSE Standard 1024. It shall be bronze-bodied with top and bottom guided plastic check assemblies. The dual check shall have three plugged test ports and shall be capable of being tested in-line. Dual check shall have two top-mounted covers for in-line service. Check assembly shall be designed without screws located within the waterway and shall be fully guided throughout its range of travel. Dual check shall be an Ames Fire & Waterworks Series L20. (Please select the model best suited to your application.)

Materials

Cast bronze body, plastic check assemblies, silicone discs and stainless steel springs.

Product Availabilities

Series L20: Inlet Connections - Types available, ordering code, sizes available

Type	Connection Code	Sizes Available	
		inches	mm
National Pipe Thread Female	2	3/4, 1	20, 25
National Pipe Thread Male	3	3/4, 1	20, 25
Meter Thread Female *	4	3/4, 1	20, 25
Meter Thread Male *	5	3/4, 1	20, 25
Pack Joint Female	6	3/4, 1	20, 25
Pack Joint Male	7	3/4, 1	20, 25
Female Solder	8	3/4, 1	20, 25
Male Solder	9	3/4, 1	20, 25
Female Meter Thread (Swivel)	10	3/4, 1	20, 25
Male Hose Thread	11	3/4, 1	20, 25
Female Hose Thread	12	3/4, 1	20, 25

Series L20: Outlet Connections - Types available, ordering code, sizes available

National Pipe Thread Female	2	3/4, 1	20, 25
Meter Thread Female	4	3/4, 1	20, 25
Female Hose Thread	12	3/4	20

See "How To Order" on pages 7.

Union (U) Connections available on all inlet/outlet types and sizes.

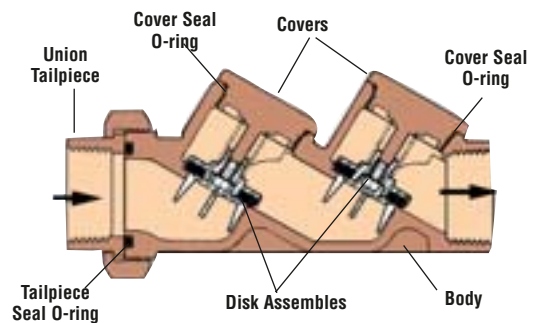
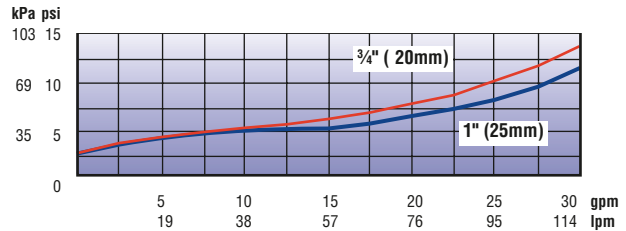

Pressure / Temperature

Maximum Pressure: 175psi (12.06 bar).

Working Temperature: 33°F – 140°F sustained; intermittent to 180°F (0.6°C – 60°C sustained; intermittent to 82.2°C).

* When ordering Series L20 Valves with Meter Thread Connections be sure to order the meter connections one size larger than meter.

Examples:

For 1/2" (15mm) and 5/8" (16mm) water meter; order 3/4" (20mm) meter thread connection.

For 5/8" (16mm) and 3/4" (20mm) water meter; order 1" (25mm) meter thread connection.

For 1" (25mm) water meter; order 1 1/4" (32mm) meter thread connection.

Dimensions / Weight

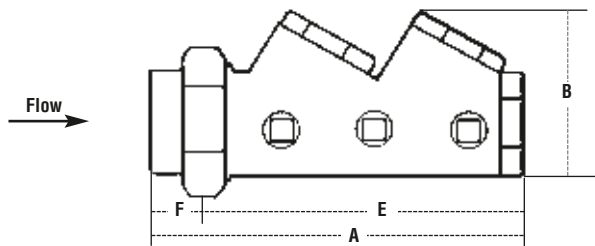

Size		A		B		E		F		Weight	
in.	mm	in.	mm	in.	mm	in.	mm	in.	mm	lbs.	kgs.
3/4	20	5 3/4	146	2 5/8	67	4 7/8	124	3/4	19	2.3	1.0
1	25	5 3/4	146	2 5/8	67	4 15/16	124	1	25	2.3	1.0

Series 20S

Residential Fire Sprinkler System Dual Check Backflow Preventers

Size: 1" and 1¼" (25 and 32mm)

Description

Installed at the residential fire sprinkler service connection to the main, Series 20S Dual Check Backflow Preventers protect the water supply against polluted water being siphoned back from the sprinkler system.

Standards

Tested and certified under ANSI/ASSE Standard 1024, UL Classified file # EX3185, and complies with NFPA Standard 13D for flow requirements to residential fire sprinklers. (1" Size only female by female end connections.)



Important: Inquire with governing authorities for local installation requirements.

Specification

The dual check backflow preventer shall meet the requirements of ANSI/ASSE Standard 1024 and be UL Classified. It shall be bronze-bodied and feature replaceable seats and silicone seat discs. The springs shall be captured to prevent injury. The valve shall be capable of flow rate in excess of 50 gpm. Pressure drop at 30 gpm shall not exceed 6psi. An identification tag shall be securely attached to the body by corrosion-resistant mechanical fasteners and a union connection shall be provided. The dual check shall be an Ames Fire & Waterworks Series 20S.

Materials

Cast bronze body, durable plastic check modules, silicone discs and Buna 'N' seals, stainless steel springs, one union and O-ring union seal.

Product Availabilities

Series 20S: Inlet Connections - Types available, ordering code, sizes available

Connection Type	Connection Code	Sizes Available	
		inches	mm
Meter Thread Female	4	1, 1¼	25, 32
*National Pipe Thread Female	2	1, 1¼	25, 32

Series 20S: Outlet Connections - Types available, ordering code, sizes available

Connection Type	Connection Code	Sizes Available	
		inches	mm
Meter Thread Male	5	1, 1¼	25, 32
National Pipe Thread Male	3	1, 1¼	25, 32
*National Pipe Thread Female	2	1 (only)	25

See "How To Order" on page 8.

Dimensions / Weight

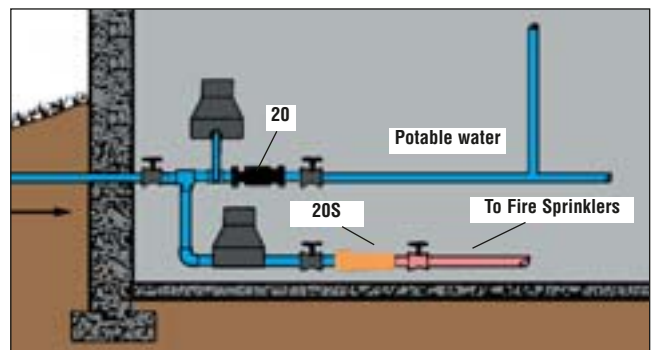
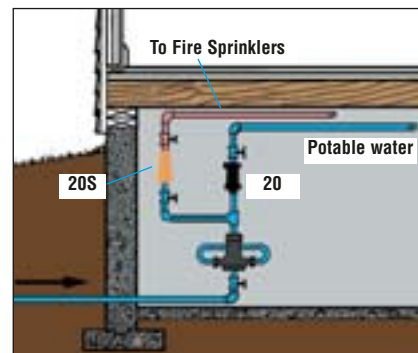
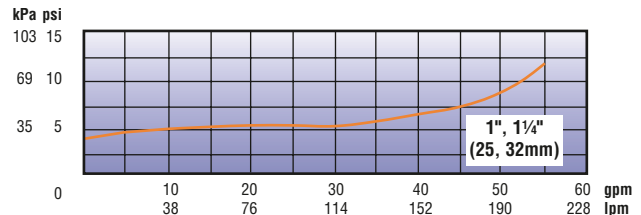
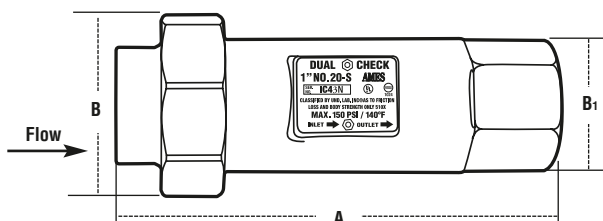

Pressure / Temperature

Maximum Pressure: 175psi (12.06 bar).

Working Temperature: 33°F – 140°F sustained; intermittent to 180°F (0.6°C – 60°C sustained; intermittent to 82.2°C).

Maximum recommended flow: 50 gpm (190 lpm).

* The 1" 20S is standardly supplied with female end connections.

A		B		B1		Weight	
in.	mm	in.	mm	in.	mm	lbs.	kgs.
6¾	171	21⅞	71	2	50	3	1.36

Series Cu20

Copper-Bodied Dual Check Backflow Preventers

Sizes: 1/2" – 1" (15 – 25mm)

Description

The straight line, poppet-type construction of the Cu20 minimizes pressure drop and provides smooth flow characteristics. It can be installed horizontally or vertically. The copper body of the Series Cu20 is lead free and is of a time proven durable material. All models are standardly furnished with double unions for ease of installation and repair.

Standards

Tested and certified to meet ANSI/ASSE Standard 1024. Tested and certified to ANSI/NSF standard 61.



Specifications

The dual check backflow preventer shall meet ASSE 1024. The valve body shall be of copper tube construction and shall be furnished with double unions to facilitate installation. The check module shall be of a modular design and shall include limit stops to prevent over compression or damage to the check valves due to water hammer or thermal expansion. Each check valve shall be both center and edge-guided to ensure repeatable seating and minimize localized wear. The dual check shall be an Ames Fire & Waterworks Series Cu20.

Materials

Copper body, corrosion resistant plastic check modules, silicone discs and Buna 'N' seals, stainless steel springs.

Pressure / Temperature

Maximum Pressure: 150psi (10 bar)

Working Temperature: 33°F – 180°F (.6°C – 82°C) continuous

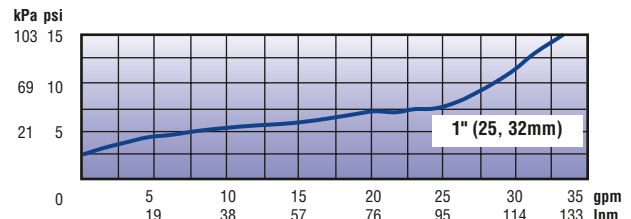
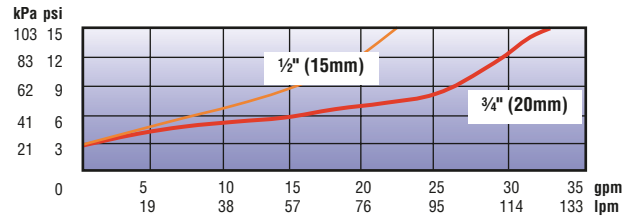

Dimensions / Weight

Product Availabilities

Series Cu20: Inlet/Outlet Connections - Types available, ordering code, sizes available

Connection Type	Connection Code	Sizes Available	
		inches	mm
National Pipe Thread Female	2	1/2", 3/4", 1"	15, 20, 25
National Pipe Thread Male	3	1/2", 3/4", 1"	15, 20, 25
Meter Thread Female*	4	3/4", 1"	20, 25
Meter Thread Male*	5	3/4", 1"	20, 25
Female Solder	8	3/4", 1"	20, 25
Female Meter Thread (Swivel)	10	3/4", 1"	20, 25

See "How to Order" on pages 8.

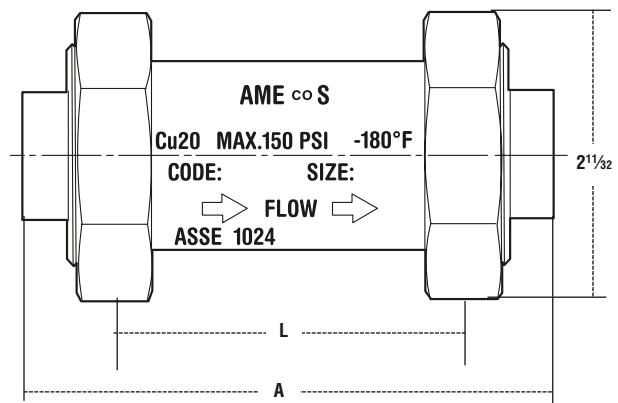

Size		A		L		Weight	
in.	mm	in.	mm	in.	mm	lbs.	kg.
1/2	15	4 7/16	113	2 1/16	69	1.7	3.7
3/4	20	4 7/16	113	2 1/16	69	1.7	3.7
1	25	4 11/16	119	2 1/16	69	2.0	4.4

HOW TO ORDER

Ames Dual Check Backflow Preventers can be specified in many different combinations of connection types, sizes, and union options. See ordering example below.

Specify Series No. | Specify "U" if union inlet is desired | Specify inlet connection code | Specify "U" if union outlet is desired | Specify outlet connection code | Specify inlet connection size | Specify outlet connection size

20 | U | 2 | - | U | 2 | 3/4" (20mm) X 3/4" (20mm)

Series 20

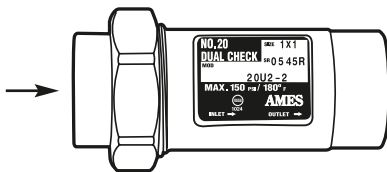

20U2-2 3/4" (20mm) x 3/4" (20mm) shown

* When ordering Series 20 Valves with Meter Thread Connections, be sure to order connection size one size larger than meter thread. Examples:

Meter Size	Order
1/2" (15mm) and 5/8" (16mm)	3/4" (20mm)
5/8" (16mm) and 3/4" (20mm)	1" (25mm)
1" (25mm)	1 1/4" (32mm)

Series L20

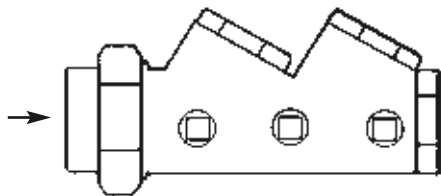

L20U2-2 1" (25mm) x 1" (25mm) shown

* When ordering Series L20 Valves with Meter Thread Connections, be sure to order connection one size larger than meter thread. Examples:

Meter Size	Order
1/2" (15mm) and 5/8" (16mm)	3/4" (20mm)
5/8" (16mm) and 3/4" (20mm)	1" (25mm)
1" (25mm)	1 1/4" (32mm)

Series 20: Inlet/Outlet Connections – Types available, ordering code, sizes available.

Connection Type	Connection Code	Sizes Available	
		inches	mm
National Pipe Thread Female	2	1/2, 3/4, 1	15, 20, 25
National Pipe Thread Male	3	1/2, 3/4, 1, 1 1/4	15, 20, 25, 32
Meter Thread Female*	4	3/4, 1, 1 1/4	20, 25, 32
Meter Thread Male*	5	3/4, 1, 1 1/4	20, 25, 32
Pack Joint Female	6	3/4, 1	20, 25
Pack Joint Male	7	3/4, 1	20, 25
Female Solder	8	3/4, 1	20, 25
Male Sweat	9	3/4, 1	20, 25
Female Meter Thread (Swivel)	10	3/4, 1, 1 1/4	20, 25, 32
Male Hose Thread	11	3/4	20
Female Hose Thread	12	3/4	20
Male Meter Yoke Thread	13	3/4	20
PEX	15	1/2, 3/4, 1	15, 20, 25
CPVC	16	1/2, 3/4, 1	15, 20, 25

Union (U) Connections available on all inlet/outlet types and sizes.

20 - U - - - - " X - - - - "

Series L20: Inlet Connections - Types available, ordering code, sizes available

Connection Type	Connection Code	Sizes Available	
		inches	mm
National Pipe Thread Female	2	3/4, 1	20, 25
National Pipe Thread Male	3	3/4, 1	20, 25
Meter Thread Female *	4	3/4, 1	20, 25
Meter Thread Male *	5	3/4, 1	20, 25
Pack Joint Female	6	3/4, 1	20, 25
Pack Joint Male	7	3/4, 1	20, 25
Female Solder	8	3/4, 1	20, 25
Male Solder	9	3/4, 1	20, 25
Female Meter Thread (Swivel)	10	3/4, 1	20, 25
Male Hose Thread	11	3/4, 1	20, 25
Female Hose Thread	12	3/4, 1	20, 25

Series L20: Outlet Connections - Types available, ordering code, sizes available

National Pipe Thread Female	2	3/4, 1	20, 25
Meter Thread Female	4	3/4, 1	20, 25
Female Hose Thread	12	3/4	20

Union (U) Connections available on all inlet/outlet types and sizes

L20 U - (N/A) - - - - " X - - - - "

Series 20S

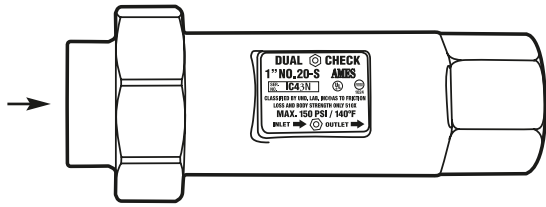

20SU4-4 1" (25mm) x 1" (25mm) shown

Series 20S: Inlet Connections - Types available, ordering code, sizes available

Connection Type	Connection Code	Sizes Available	
		inches	mm
Meter Thread Female	4	1, 1¼	25, 32
National Pipe Thread Male	2	1, 1¼	25, 32

Series 20S: Outlet Connections - Types available, ordering code, sizes available

Meter Thread Male	5	1, 1¼	25, 32
National Pipe Thread Male	3	1, 1¼	25, 32

Union (U) Connections available on all inlet/outlet types and sizes

20S _____ - _____ 1¼" x 1¼"
(32m) (32m)

Series Cu20

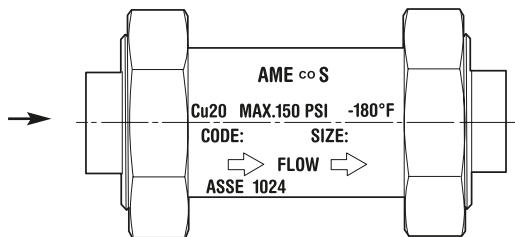

Cu20 ¾" (20mm) x 1" (25mm) shown

Series Cu20: Inlet/Outlet Connections - Types available, ordering code, sizes available

Connection Type	Connection Code	Sizes Available	
		inches	mm
National Pipe Thread Female	2	½", ¾", 1"	15, 20, 25
National Pipe Thread Male	3	½", ¾", 1"	15, 20, 25
Meter Thread Female*	4	¾", 1"	20, 25
Meter Thread Male*	5	¾", 1"	20, 25
Female Solder	8	¾", 1"	20, 25
Female Meter Thread (Swivel)	10	¾", 1"	20, 25

* When ordering Series Cu20 Valves with Meter Thread Connections, be sure to order connection one size larger than meter thread. Examples:

Meter Size	Order
½" (15mm) and ⅝" (16mm)	¾" (20mm)
⅝" (16mm) and ¾" (20mm)	1" (25mm)

Cu20 U _____ - U _____ " x _____ "



A Division of Watts Regulator Company

www.amesfirewater.com



1427 North Market Blvd. • Suite #9 • Sacramento, CA 95834 • Phone: 916-928-0123 • Fax: 916-928-9333