

**MICRO 200 BW TURBIDIMETER
RANGE 0 - 10 AND 0 - 100 NTU**

HF scientific, inc.
3170 Metro Parkway
Ft. Myers, FL 33916-7597
Phone: (239) 337-2116
Fax: (239) 332-7643
www.hfscientific.com

FOREWORD

HF TURBIDIMETERS

HF turbidimeters are manufactured to meet design criteria for nephelometers as described in Standard Methods For Examination of Water and Wastewater. HF turbidimeters are approved by the U.S. EPA* as a means to measure the turbidity of potable water, waste water, and other liquids.

HF turbidimeters provide a linear display of turbidity, throughout all ranges, in Nephelometric Turbidity Units (NTU). HF turbidimeters use solid state electronic components because they resist thermal variation and are not affected by normal line voltage fluctuations.

HF turbidimeters can be calibrated using HF scientific factory certified Secondary Standards or Formazin. Factory calibration is accomplished using HF scientific Secondary Standards, which are factory certified traceable to Formazin, therefore, this instruction manual describes the proper procedures for calibration of HF turbidimeters using Secondary Standards.

HF turbidimeter manuals are designed to assist the user in taking full advantage of the instrument in a majority of its applications. However, in the event that unusual circumstances or problems, not covered by this manual, arise please feel free to contact our local distributor or the manufacturer.

HF scientific, inc.
3170 Metro Parkway
Fort Myers, Florida 33916-7597
Phone: (239) 337-2116
Fax: (239) 332-7643

Our engineering staff is available to help you with your specific needs.

CERTIFICATION

Congratulations! We at HF scientific are proud to present you with the MICRO 200 BW turbidimeter. This instrument represents the very latest in integrated circuit and display technology. As a result, the product is a rugged and reliable instrument whose performance was tested thoroughly and found to meet its published specifications when it left the factory.

**EPA approved means the instrument meets or exceeds the design and performance criteria as specified in the United States Environmental Protection Agency method 180.1.*

DECLARATION OF CONFORMITY

Application of Council Directive: 73/23/EEC

Standard to which Conformity is Declared:

Product Safety	Immunity	EMI
UL3111-1	EN50082-1	EN55011 Group 1 Class A
CSA-C22.2 No.1010-1-92	IEC801-2	FCC Part 15 Class A
CE EN61010-1	IEC801-3	
	IEC801-4	

Manufacture's Name: HF scientific, inc.

Manufacture's Address: 3170 Metro Parkway, Fort Myers, Florida 33916-7597

Importer's Name:

Importer's Address:

Type of Equipment: Turbidimeter

Model No.: Micro 200/200BW

I, the undersigned, hereby declare that the equipment specified above conforms to the above Directive and Standard.

Place: Fort Myers, Florida USA

(Signature)

Robert J. Maley, President
(Full Name)

DECLARATION OF CONFORMITY

Application of Council Directive: 73/23/EEC

Standard to which Conformity is Declared:

Product Safety	Immunity	EMI
UL3111-1	EN50082-1	EN55011 Group 1 Class A
CSA-C22.2 No.1010-1-92	IEC801-2	FCC Part 15 Class A
CE EN61010-1	IEC801-3	
	IEC901-4	

Manufacture's Name: HF scientific, inc.

Manufacture's Address: 3170 Metro Parkway, Fort Myers, Florida 33916-7597

Importer's Name:

Importer's Address:

Type of Equipment: Backwash Sensor and Interface Kit

Model No.: 19276

I, the undersigned, hereby declare that the equipment specified above conforms to the above Directive and Standard.

Place: Fort Myers, Florida USA

(Signature)

Robert J. Maley, President
(Full Name)

MICRO 200 BW

TABLE OF CONTENTS

1.0	IMPORTANT INFORMATION	
1		
1.1	HOW TO USE THIS MANUAL	1
1.2	SPECIAL ENVIRONMENTAL CONSIDERATIONS	1
1.3	SPECIFICATIONS	2
1.4	OPTIONS	3
1.5	FIGURES	4
1.6	COMPLIANCE TESTING CERTIFICATION	5
2.0	INSTALLATION	
6		
2.1	PACKING LIST OF CONTENTS	6
2.2	UNPACKING AND INSPECTION	6
2.3	MOUNTING	6
2.3.1	Analyzer	6
2.3.2	Sensor - Turbidity	6
2.3.2.1	Installing Desiccant Tray	6
2.4	ANALYZER CONNECTIONS	9
2.4.1	Cable & Cord	9
2.4.2	Analyzer Power	9
2.4.3	D/A Outputs - Voltage & Current	10
2.4.4	Recorder - Voltage	10
2.4.5	Recorder - Current	10
2.4.6	4 - 20 mA Isolation	10
2.4.7	Alarm Contacts	11
2.4.8	Cable Mount Ferrites	11
2.5	TURBIDITY SENSOR	11
2.5.1	Interconnecting Cable	11
2.5.2	Inserts for sample and drain lines	11
3.0	STEP-BY-STEP OPERATION	
11		
3.1	THEORY & HOW IT WORKS	11
3.2	MENU GUIDE TO THE MICRO 200 BW	12
3.2.1	Turbidity Display	13
3.2.2	Main Menu	14
3.2.3	Sensor Setup	15
3.2.4	Alarm Setup	17
3.2.5	Display Parameters	19
3.2.6	Monitor Setup	21
3.2.7	Backwash Display	24
3.3	START UP	25
3.3.1	Indexing	25
3.3.2	Standardizing	25
4.0	ROUTINE OPERATION	
25		
4.1	CONTINUOUS MONITORING FLOW THROUGH UNIT	25
4.2	VAPORPURGE	26
4.3	GRAB SAMPLES	26

MICRO 200 BW

TABLE OF CONTENTS CONT.

5.0	ROUTINE MAINTENANCE	
26		
5.1	CUVETTE CLEANING & CARE	26
5.2	LAMP REPLACEMENT	28
5.3	CALIBRATION PROCEDURES	28
5.3.1	Calibration Standards	28
5.3.1.1	PRIME TIME Standard Set (Optional) Cat. No. 19820	28
5.3.1.2	Standard Formazin Solutions	28
5.3.2	Calibration Steps for 0-10 NTU Range	29
5.3.3	Calibration Steps for 0-100 NTU Range	29
6.0	SECURITY ACCESS CODE	
30		
7.0	TROUBLESHOOTING	31
7.1	GENERAL NOTES	31
7.2	SPARE PARTS LIST FOR MICRO 200 BW	32
8.0	OPTIONS	33
	BACKWASH	
33		
8.1	INSTALLATION	33
8.1.1	Backwash Interface	33
8.1.2	Junction Box	33
8.1.3	Backwash Sensor	33
8.1.3.1	Channel Mounting	33
8.1.3.2	Extension Handle Mounting	33
8.2	BACKWASH SENSOR CONNECTIONS	33
8.3	BACKWASH SENSOR MAINTENANCE	34
8.3.1	Backwash Calibration	34
8.4	BACKWASH ALARMS	34
8.5	BACKWASH REMOTE SWITCHING	34
8.5.1	Electrical Connections	34
8.5.1.1	Remote Switch	34
8.5.1.2	Alarms	34
8.5.1.3	Analog Outputs	35
8.5.1.4	Serial Port (Optional)	35
8.5.2	Operation	35
	SERIAL INTERFACES	
40		
8.6	SERIAL INTERFACES	40
8.6.1	RS-232 Voltage Mode Interface	40
8.6.2	RS-485 Interface	40
8.6.3	Serial Printer	41
	WARRANTY	43
	GLOSSARY	44

1.0 IMPORTANT INFORMATION

1.1 HOW TO USE THIS MANUAL

The equipment has been designed for simple and easy operation. In keeping with that philosophy, this MICRO 200 BW User's Manual has been written to simplify all steps in the procedures that follow.

THE MOST IMPORTANT ASPECT OF THIS MANUAL IS THAT YOU, THE USER, READ IT IN ITS ENTIRETY AND REFER TO IT OFTEN. Figures and drawings have been used throughout the manual to show you how and text has been used to enhance and clarify what you have been shown.

Again, please read the manual before attempting to install or operate the MICRO 200 BW. Pay particular attention to the "warning" and "caution" messages throughout. Although the MICRO 200 BW is simple and easy to use, all electrical and safety precautions must be followed. "Notes" have also been added to give further clarification or reminders in certain instances.

1.2 SPECIAL ENVIRONMENTAL CONSIDERATIONS

The Liquid Crystal Display (LCD) is not recommended for outdoor installation. UV rays are damaging to the display. For more details, see the Installation Section regarding Mounting of the MICRO 200 BW.

1.3 SPECIFICATIONS FOR THE MICRO 200 BW

Specification	MICRO 200 BW	
Ranges:	0 - 10.0000 NTU & 0 - 100.00 NTU	
Method:	EPA approved* Nephelometric	
Accuracy±:	10 NTU range 100 NTU range	1% of reading or 0.005 NTU (whichever is greater) 2% of reading 1 - 40 NTU, 5% of reading 40 - 100 NTU
Repeatability:	1%	
Linearity±:	1%	
Resolution:	0 to 10 NTU 1 to 100 NTU	0.0001 0.01
Digital Display:	LCD 6 digits	
Analyzer Graphics:	Built in LCD, Graphics recorder	
Clock Graphics:	Date and Time	
Response Time:	1 to 8 seconds	
Averaging Time (Electronic):	1, 16, 48 & 96 seconds, sliding average	
Microprocessor:	Motorola MC68HC11	
Keyboard data entry system:	8 interacting membrane switches with tactile feedback	
Security Code:	Prevents unauthorized access to analyzer	
Built in diagnostics:	Yes	
Analog Output, Isolated:	Bracketed to .01 NTU, 4 - 20 mA & .1, 1 & 10 VDC 12 bit resolution D/A	
Alarms:	1 system alarm, 2 (NTU or % T) alarms (Hi, Lo and Off)	
Alarm Contact rating:	Max. 250 VAC @ 5.0 A	
Operating Temperature:	32° to 122°F (0°C to 50°C)	
Storage Temperature:	-4°F to 140°F (-20° to 60°C)	
Optical Cleaning for NTU Sensor:	Removable cuvette	
Flow rate:	0.5 - 1.5 gpm (2000 ml/min - 6.0 L/m)	
Positive System Pressure:	60 psi maximum (414 kPa or 4.22 kg/cm ³)	
Wetted surfaces:	Nylon, C.A.B., PVC, Delrin-500, Borosilicate glass, Silicone	
Lamp:	External, prefocused module	
Standard Cable Length:	6 feet (1.83 m)	
Sensor to analyzer distance:	250 feet (76.25 m) max. Over 50' lengths contact factory.	
Dimensions		
Analyzer:	13" x 11½" x 8" (330 x 290 x 200 mm)	
NTU Sensor:	8¾" x 9¾" x 8" (225 x 250 x 200 mm)	
NTU Sensor Case:	NEMA 4X	
CE Rating:	Pollution Degree 2, Overvoltage Category III	
Supply Voltage:	120 VAC ± 10% 50/60 Hz 240 VAC ± 10% 50/60 Hz	
Power Consumption:	40 VA	

*EPA approved means that the instrument meets or exceeds the design and performance criteria as specified in the United States Environmental Protection Agency Method 180.1.

1.3 SPECIFICATIONS FOR THE MICRO 200 BW CONTINUED

Specifications	Micro 200 BW
Shipping Weight:	Approximately 15 lbs. (6.8 kg)
Warranty:	One year from date of shipment

Backwash Sensor - Optional:	
Backwash Sensor:	IR sensor measures 0 - 100% Transmittance
Sensor operating depth:	16 psi (32 ft.: 9.8 m) maximum depth
Standard cable lengths	
Sensor to Backwash/Interface:	30 feet (9.2 m)
Interface to Analyzer :	50 feet (15m)
Maximum cable lengths	
Sensor to Backwash/Interface:	250 feet (76m)
Interface to Analyzer :	1000 feet (305m)
Backwash Sensor Dimensions:	3" Dia. x 7" H (75 x 175 mm)
Backwash Sensor Case:	NEMA 4X
Repeatability±:	1% Transmittance
Sensitivity±:	1% Transmittance
Linearity±:	1% Transmittance
Response time:	Less than 10 seconds for a full scale change
Sensor operating temperature:	32 to 86°F (0°C to 30°C)

1.4 OPTIONS:

Specifications	Micro 200 BW
Printer:	120/240V, 32 column, provides a 4 or 24 hour data printout of station, date, time, high, low, average NEMA 4X enclosure. Includes 10 feet of interconnect cable, paper printer roll, operating manual.
Computer Interface Serial Port:	RS-232 or RS-485/RS-422
Display Languages:	English, French, German, Spanish, Italian or Swedish

1.5 FIGURES

Figure No.	Title	Page No.
1	Desiccant Tray Installation	6
2	Analyzer Outline Dimensions	7
3	Turbidity Sensor Outline Dimensions	7
4	Installation Diagram	8
5	Access Cover Removal	9
6	Cable Routing	9
7	Changing Analyzer Voltage/Fuse	10
8	Analyzer Rear Cover Removal	10
9	4 - 20 mA Isolation Jumper (Removal)	10
10	Calibration Standard Indexing	25
11	Flow Through Cuvette Indexing	26
12	Vaporpurge	27
13	Critical Measurement Area	28
14	Lamp Replacement	28
15	Analyzer BNC Connection	33
16	Backwash Interface Outline Dimensions	36
17	Backwash Interface Voltage Selection	36
18	Junction Box Outline Dimensions	37
19	Junction Box Wiring Diagram	37
20	Backwash Sensor Outline Dimensions	38
21	Backwash Channel Mounting	38
22	Backwash Extension Handle Mounting	39
23	Serial Interface Installation	40
24	RS-232 Voltage Connection	42
25	RS-485 Connection	42
26	Menu Flow Chart	45

1.6 COMPLIANCE TESTING CERTIFICATION

The Micro 200 BW has undergone extensive testing, therefore, HF scientific, inc. certifies that this instrument has met the following standards.

Product Safety

US standard tested by ETL testing labs to UL 3111
Canadian Standard tested by ETL to CSA 1010.

CE tested by ETL testing labs to EN61010-1

Pollution Degree 2, Installation Category (Overvoltage Category) III

Immunity

Immunity testing by ETL testing labs to EN50082-1 including:

ESD Immunity to IEC 801-2

RF Immunity to IEC 801-3

Transient Burst Immunity to IEC 801-4

EMI

EMI tested by ETL testing labs to EN55011 Group 1 Class A.

RF Emissions to FCC Part 15 Class A by ETL testing labs

2.0 INSTALLATION

2.1 PACKING LIST FOR THE MICRO 200 BW

<u>CONTENTS</u>	<u>QUANTITY</u>
Instruction Manual	1
MICRO 200 BW Instrument	1
Desiccant Tray Assembly	1
50125A Tubing Kit - includes:	1
-Shutoff clamp	
-Backpressure Valve	
-Connecting tubing with fittings for flow-through assembly	
-Drain Vent Screw (only required for pressurized system)	
Accessory kit - includes:	
-0.02 NTU calibration standard	1
-Spare flow through cuvette	1
-Light Shield Cap	1

A listing of recommended spare parts appears on page 32 of this manual.

2.2 UNPACKING AND INSPECTION

Use extreme care when unpacking your MICRO 200 BW and note that all of the contents are included. Check for any damage that may have occurred during shipping. If there are any omissions, report this immediately to the your local distributor or the Quality Assurance Dept. at HF scientific, inc. If there is **any** shipping damage; notify the shipping company immediately and arrange for a prompt inspection.

2.3 MOUNTING

CAUTION: Instrument is not designed for outdoor installation. The LCD screen will be damaged by UV rays. Contact factory for available enclosures.

The maximum allowable ambient temperature is 122°F (50°C).

NOTE: Be careful during installation not to violate the moisture integrity of the sensor, interface or analyzer housings. The analyzer requires approximately two hours to reach its final operating temperature. Further adjustment of the

LCD brightness may be required during this period.

2.3.1 Analyzer

The location of the analyzer should be given careful consideration. As an example, if the MICRO 200 BW is to be used for performing backwash, the analyzer must be mounted where it can be viewed at the backwash control station. In this example, for convenience of maintenance, the turbidity sensor should be mounted at the backwash station and have the water plumbed to it. The analyzer must be mounted in a location that avoids direct water contact. Refer to figure 2 for outline dimensions. Allow enough room for the analyzer to pivot on the mounting bracket upside down, to make connections.

After mounting, the angle of analyzer may be adjusted for best visibility.

2.3.2 Sensor - Turbidity

For the outline drawing of the turbidity sensor refer to figure 3 on page 7. Allow enough room for easy access to both the flow through unit and the lamp module. Avoid mounting the sensor in a location that will put the sensor housing in contact with dripping water, as this will present problems when performing periodic maintenance.

The sensor is equipped with a foot valve, that opens in case the flow through cuvette ruptures, to prevent damage to the sensor. The foot valve drain tube can be connected to a 5/8" (15.9 mm) tube (not supplied) to direct the flow of water to a convenient drain. Keep the length of this external tube to a minimum.

CAUTION: The foot valve system will handle up to 1 gallon per minute. Flow rates higher than this will cause the sensor to flood.

2.3.2.1 Installing & Replacing Pack Desiccant Tray

Before operating the Micro 200BW for the first time the replaceable desiccant pouch must be installed. Please refer to Figure 1 (page 9) while installing for the first time. To initially install, unscrew the four thumbscrews and remove the electronics half of the sensor. Open the bag and remove the dessicant pouch and the indicator card. Install these items and replace the top portion of the sensor.

Proper use of the supplied desiccant is essential in maintaining the performance of the instrument. The desiccant pouch is designed to have a long life;

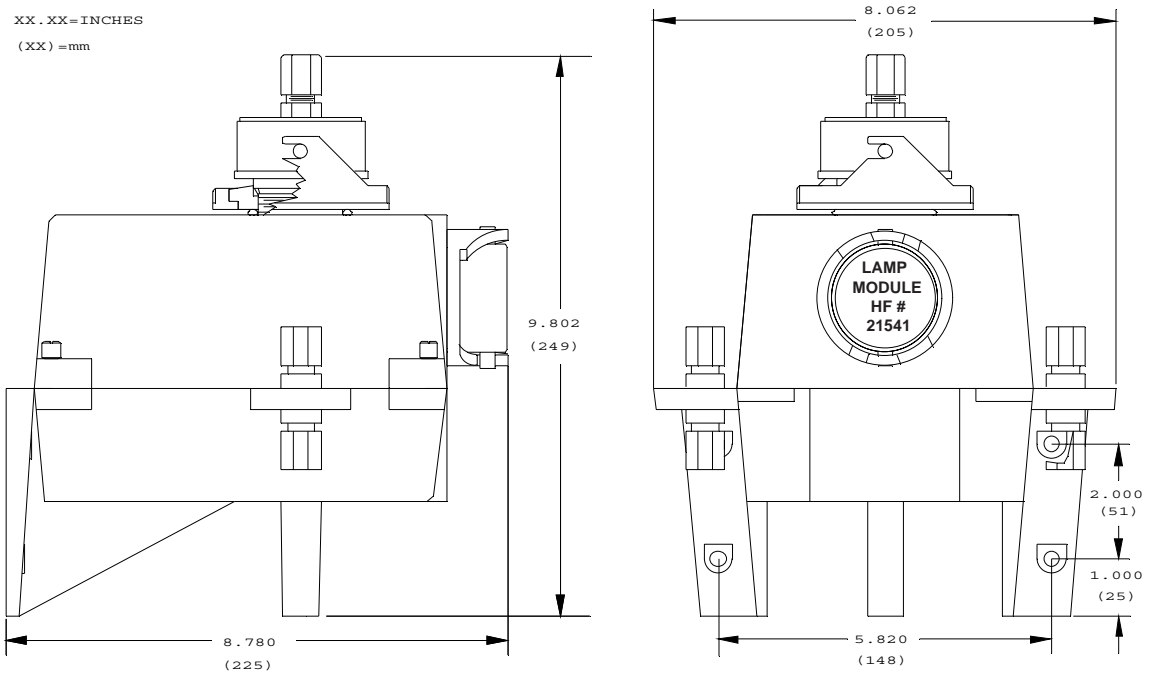
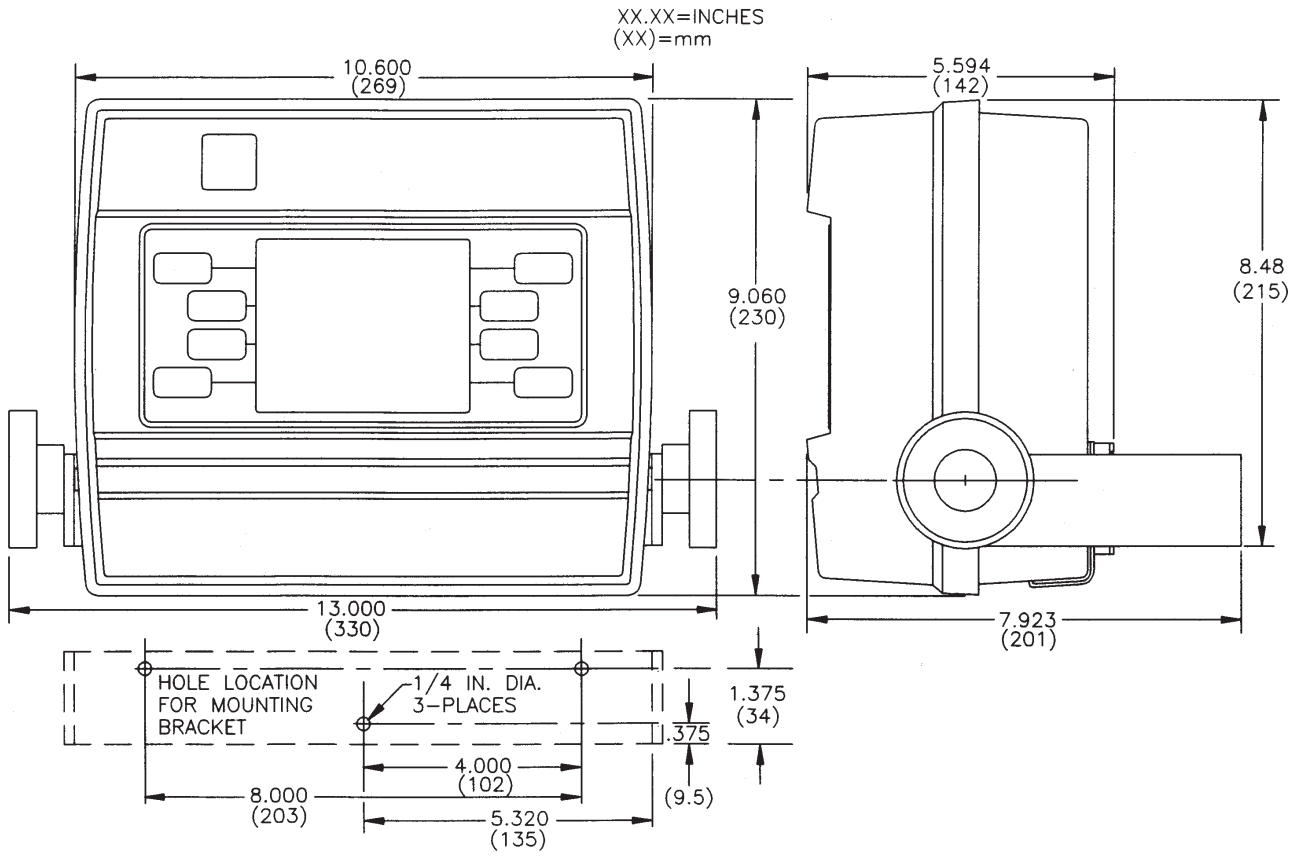

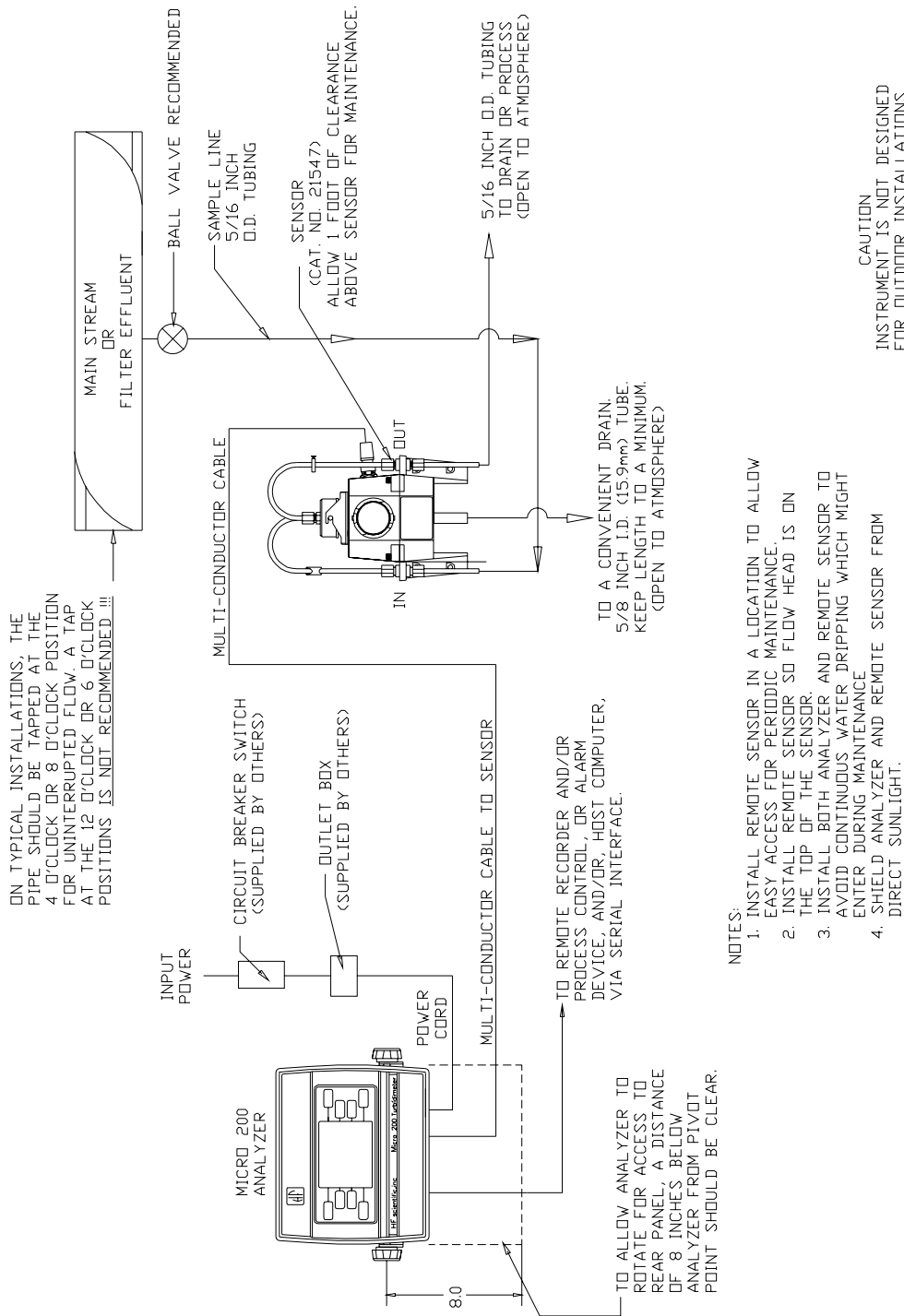

Figure 4
Installation Diagram

however, replacement of the desiccant pack will be required from time to time. To determine the condition of the desiccant, check the included humidity indicator card. If required, a new sealed desiccant pouch and indicator card are available from HF scientific inc. part #21555R.

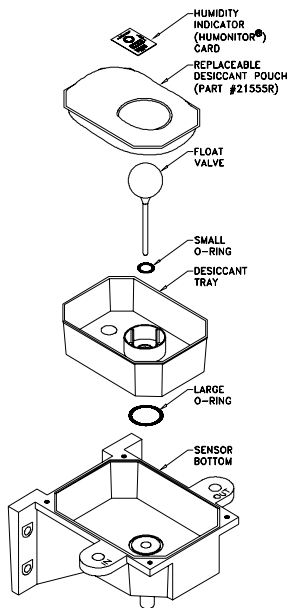

Figure 1
Desiccant Tray Installation

It is essential that all enclosure seals be maintained. The emergency drain and o-rings that are supplied with each new instrument form part of the instrument humidity seal. Inspect these items each time the desiccant pouch is replaced. Replace any parts found to be defective.

2.4 ANALYZER CONNECTIONS

All connections are reached by removing the access cover. Heed all warnings and precautions prior to removal.

WARNING: Before removing access cover disconnect all power from the MICRO 200 BW analyzer.

- 1) Unplug the instrument or
- 2) Turn off the power at the circuit breaker.
- 3) Remove power to alarm contacts if greater than 30 VAC is connected for external operations.

To remove the access cover (refer to figure 4):

- 1) Loosen the two analyzer clamping knobs.
- 2) Swivel the analyzer top forward, such that the back is now facing you.
- 3) Retighten the two analyzer clamping knobs.
- 4) Loosen the 4 captive screws.
- 5) Remove access cover.

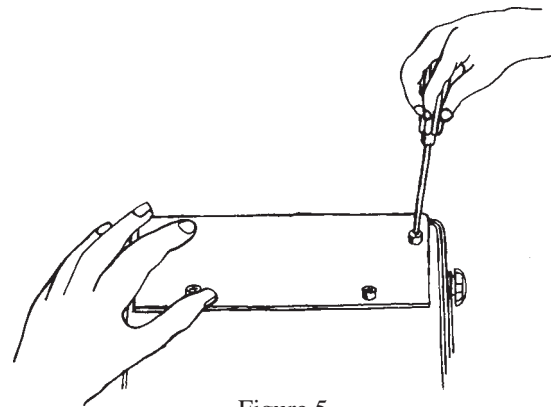
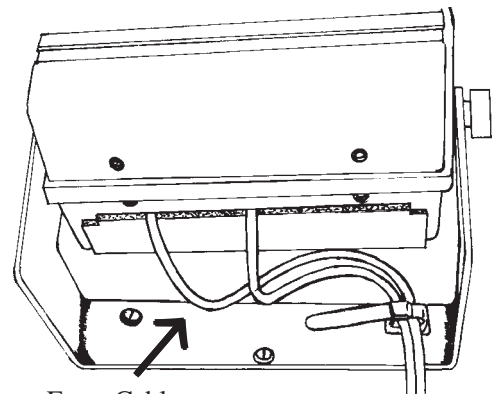

Figure 5
Access Cover Removal

WARNING: Do not restore power until the access cover has been replaced and secured. When routing the cabling for the following sections, allow enough excess cable length to swivel the analyzer upside down. Note that a cable strap is provided on the mounting bracket. Refer to figure 6 for suggested cable routing. Do not overtighten the four captive screws when replacing cover.



Extra Cable

Figure 6
Cable Routing

2.4.1 Cable & Cord

Interconnecting Cable: The standard interconnecting cable between the analyzer and the turbidity sensor is 6 feet (1.83 meters) in length (Catalog No. 20853). This length may be decreased without affecting instrument performance. For longer cable lengths consult HF scientific, inc.

WARNING: Ensure that power to the analyzer is removed prior to connecting or disconnecting the sensor.

2.4.2 Analyzer Power

The power cord (120V) provided is 6 feet (1.83 meters) long. The analyzer power requirement is 40 VA at either 120 VAC or 240 VAC. The voltage setting of the analyzer can be determined by removing the access cover and looking at the fuse cartridge, just to the left of the power cord receptacle. The voltage printed next to the two triangles that point toward each other indicate the selected voltage. To change the input voltage first remove the power cord. The fuse cartridge can be removed by prying upwards using a flat blade screwdriver in the slot provided. Pull the cartridge out, invert and then reinsert. Refer to figure 7 on page 10. To replace a blown fuse remove the fuse cartridge as in figure 7 on page 10. Replace only the fuse for your selected voltage. The triangle on the fuse cartridge points to the fuse for the voltage. The correct fuse ratings are 5 x 20 mm 1A fast acting for 120 VAC and 5 x 20 mm ½A fast acting for 240 VAC.

A power switch is located to the right of the power cord.

WARNING: If power connection is to be hard wired, place each analyzer on a separate circuit breaker or switch to allow for service. Observe all local wiring codes.

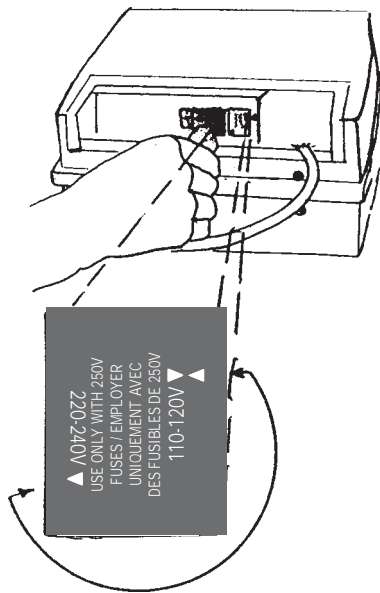

Figure 7

Changing Analyzer Voltage/Fuse

2.4.3 D/A Outputs - Voltage & Current

The full scale range of the recorder outputs, both voltage and 4 - 20 mA, is determined by the upper and lower limits selected by the user in the display parameters menu. Please note that either 4 - 20 mA **OR** voltage may be selected in the DISPLAY PARAMETERS menu, but not both.

2.4.4 Recorder - Voltage

Recorder output voltage is selected at the terminal block labeled ANALOG VOLTAGE (J6). Only one of these voltages is to be selected at any time.

Recorder load for each voltage:

Terminal 1	0 - 10V	50000 ohms or greater
Terminal 2	0 - 1V	5000 ohms or greater
Terminal 3	0 - 100mV	500 ohms or greater
Terminal 4	Common	

Twisted pair shielded cable, 22 AWG - 14 AWG, is recommended. Tie the shield to the ground terminal the recorder end (**Do not connect shield to MICRO 200 BW analyzer**).

2.4.5 Recorder - Current

A 4-20 mA current output is available. The connections are made at the terminal block labeled Analog 4-20 mA (J5). Use twisted pair shielded cable, 22 AWG - 14 AWG, with the shield tied to earth ground at the recorder end. (**Do not tie shield to ground at the analyzer**). The recorder load may be rated from 0-1000 ohms maximum. Terminal #1 is positive, terminal #2 is negative.

2.4.6 4 - 20 mA Isolation

Isolation of the 4 - 20 mA recorder output may be achieved by removing the jumper at J13. This procedure requires removal of the rear cover assembly. Refer to figure 8 to remove the rear cover and figure 9 for location of jumper.

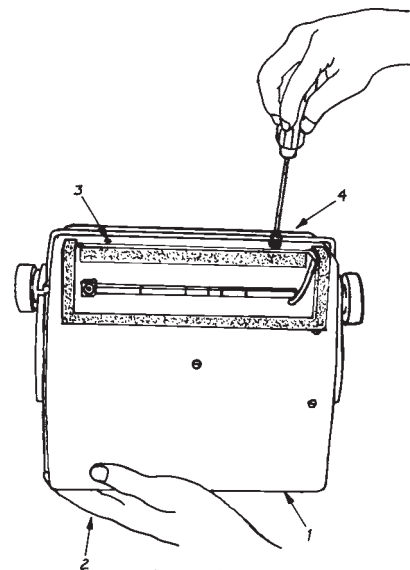

Figure 8

Analyzer Rear Cover Removal

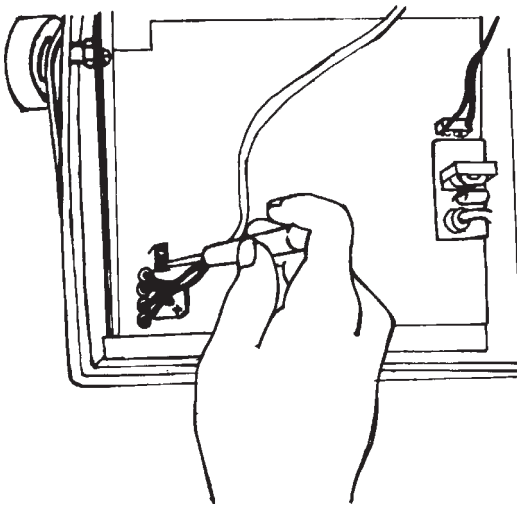

Figure 9

Remove jumper J-13 to establish isolation of the 4-20mA signal.

WARNING: While the chance is slight, there are fault conditions under which a hazardous voltage could be exposed on the analog output wires when the jumper J13 is removed. To preclude this possibility HF scientific strongly recommends, for personal protection, that a Ground Fault Circuit Interrupter (GFCI), such as LEVITON part number 6599 or 5299, be used at the power connection.

2.4.7 Alarm Contacts

Connections are provided to the alarm relay contacts on the terminal block labeled ALARMS.

NOTE: These are “fail safe” and will revert to an “alarm” condition should the power be disconnected, for any reason.

Refer to the Specifications to ensure that alarm contact ratings are not exceeded.

NOTE: ALARM 1: Terminal Block J1
 ALARM 2: Terminal Block J2
 SENSOR ALARM: Terminal Block J3

The following are the connections for each of the relay contacts:

Terminal 1: Normally Closed (N.C.) (open on alarm)
 Terminal 2: Normally Open (N.O.) (closed on alarm)
 Terminal 3: Common (C)

WARNING: Ensure that all external voltages in excess of 30 volts are disconnected before at-

tempting to make connections or disconnections from alarm terminal blocks.

The SENSOR ALARM contacts are provided to indicate that the source lamp in the sensor module has failed or that the MICRO 200 BW requires routine standardization.

NOTE: For external analyzer connection, other than power, #14 AWG is the largest wire the connecting terminals will accept.

2.4.8 Cable Mounted Ferrites

The interconnect cable has a cable mounted ferrite on it, located near the analyzer. To maintain the CE rating for EMI this ferrite HF #21140 must be in place when operating the instrument.

Some input/output connections that are made to the Micro 200 BW will also require the addition of a ferrite to maintain the CE rating for EMI. The following connections require the addition of HF# 21138: Serial Ports, Recorder Output - Current (4-20mA), Recorder Output - Voltage.

2.5 TURBIDITY SENSOR

2.5.1 Interconnect Cable

The interconnecting cable from the analyzer is plug connected at the sensor. If the interconnecting cable is removed at the analyzer end, it should be reconnected to terminal block labeled SENSOR INTERFACE (J8). The cable wire colors are labeled in front of this terminal block.

2.5.2 Inserts for Sample & Drain Lines

Plastic inserts (not needed with rigid tubing) are provided with the turbidity sensor and are intended for use with 5/16" OD x 3/16" ID (7.94 mm OD x 4.76 mm ID) flexible plastic tubing as sample and drain lines.

3.0 STEP-BY-STEP OPERATION

3.1. THEORY & HOW IT WORKS

The HF scientific, inc., MICRO 200 BW Turbidimeter is specifically designed to monitor turbidity and backwash water in water filtration plants. This is done by providing a linear display of turbidity in Nephelometric Turbidity Units (NTU). The units, FTU and NTU, are compatible. Optional backwash function is displayed in Percent Transmission (% T).

The MICRO 200 BW is a continuous reading Nephelometric instrument that measures scattered light from

particles in suspension (turbidity). The optical signal from the photodiodes is amplified and then converted to a frequency. This frequency is dependent upon the NTU level of the sample in the sample well. The resultant signal is sent to the analyzer where it is linearized for presentation on the display.

All operator controls are located on the front panel of the MICRO 200 BW. Complete displays include LCD indicators which blink in the event of an alarm of the two user set alarms and a sensor alarm.

Each feature is clearly labeled and you will be taken, step-by-step, through each one later in this section. This approach ensures **EASY** use of the HF scientific, inc., MICRO 200 BW.

One of the most important features of the MICRO 200 BW is the ease of operation. You simply press the Function Key, <F1-F4> for the selection you want to access on the LCD screen.

The information contained in this manual will help users take full advantage of the MICRO 200 BW's capabilities. In the event that unusual circumstances arise that are not addressed in the manual, contact your local distributor. Our engineering staff is also available to help you with your specific needs.

The ROM program used in the MICRO 200 BW contains confidential information which is the property of HF scientific, inc. Unauthorized disclosure, distribution or copying is prohibited. COPYRIGHT © HF SCIENTIFIC, INC. All rights reserved.

3.2 MENU GUIDE TO THE MICRO 200 BW

The following pages guide you through the menus in MICRO 200 BW and provide insight on how to use each of them. Probably the best way to learn the system is by "hands on training". After reading this section in its entirety the user should follow through each of the menus on the MICRO 200 BW. The user will find that each of the menus is arranged in a logical manner. After going through each of the menus once he will gain a familiarity with the structure. Each function is clearly labeled. A menu flow chart figure 26 is provided on page 45 for further clarity.

The functions of F1-F4 will vary according to the menu. The function will be shown beside each button. The absence of a function beside a button indicates that the button is not used in that menu.



Turns alarm contacts to "OFF". Once an alarm condition is met, the display will continue to flash until the alarm condition is removed. Once the alarm level has been exceeded, either Hi or Lo, the alarms will reset when the alarm condition has returned to non-alarm value, including the dead band value.

Once the alarm button is pushed the alarm relay is inactive until the reading has once again reached a non-alarm value (keep in mind the dead band value). After this the alarm level must be once again exceeded before the alarm contacts can again close.

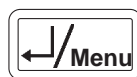

Display will change to the next highest level or previous menu. If this button is pushed several times you will always return to the Main Menu.

This button is also used to return to the turbidity display once you have made your selections.

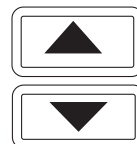

Used to scroll up or down through the values of the selected parameter.

3.2.1 Turbidity Display

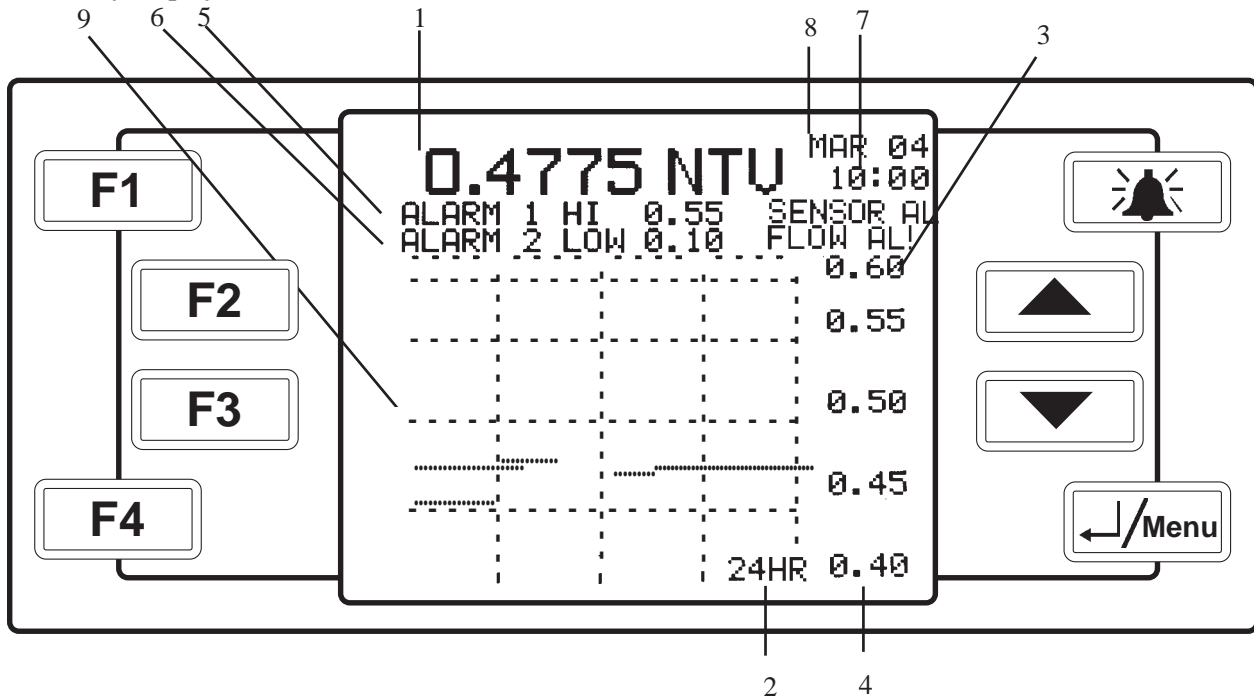

This is the turbidity display. The display shown above is fairly typical. The display has the following parameters:

- 1 - CURRENT TURBIDITY READING: 0.4775 NTU
- 2 - GRAPH TIME BASE: 24 HOURS
- 3 - GRAPH UPPER LIMIT: 0.60 NTU
- 4 - GRAPH LOWER LIMIT: 0.40 NTU
- 5 - ALARM 1 SETTING: ALARM ON HIGHER THAN 0.55 NTU
- 6 - ALARM 2 SETTING: ALARM ON LOWER THAN 0.10 NTU
- 7 - TIME: 10:00 AM (SHOWN IN 24 HOUR CLOCK MODE)
- 8 - DATE: MAR 04
- 9 - GRAPH OF TURBIDITY HISTORY

To leave the turbidity display and get to the Main Menu push . F1 - F4 are nonfunctional in this display. Please note that the graph history shows the average reading taken within the sample period.

3.2.2 Main Menu

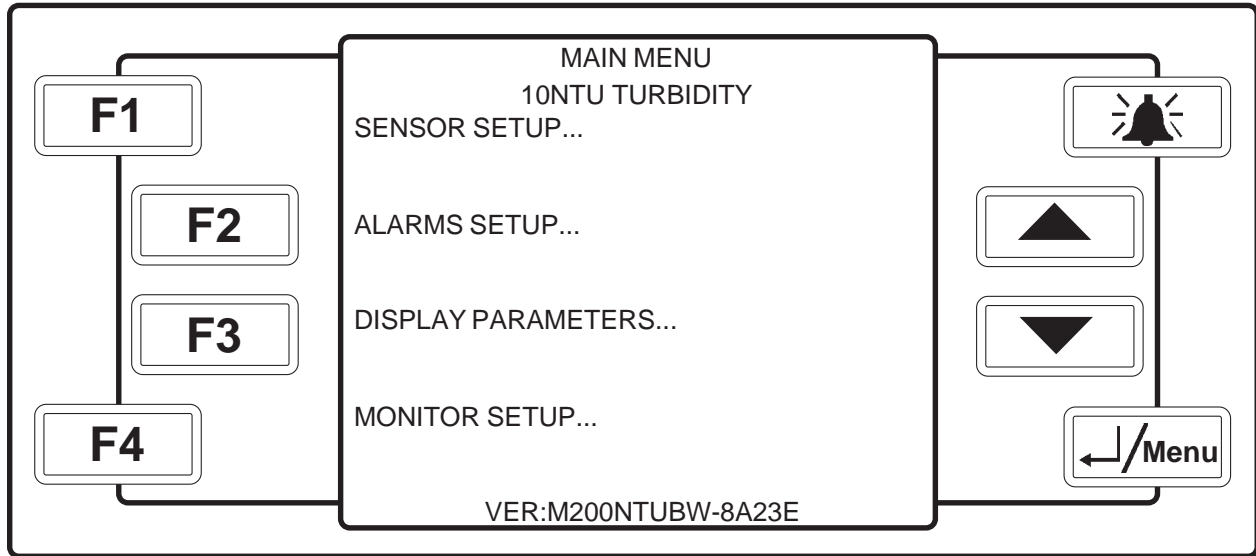

This is the main menu. It is the starting point for all sub-menu selections. Shown below are all function key selections and their purpose.

- | | |
|-----------|--|
| Selection | Options: |
| F1: | Changes screen to SENSOR SETUP MENU
Select this option to: <ul style="list-style-type: none"> Select sensor type Select unit to display Set digit suppression Three point calibration Adjust Offset Level Full Scale Calibration |
| F2: | Changes screen to ALARM SETUP MENU
Select this option to: <ul style="list-style-type: none"> Set alarm limit Set alarm mode Select deadband Flow alarm retention time |
| F3: | Changes screen to DISPLAY PARAMETERS MENU
Select this option to: <ul style="list-style-type: none"> Set screen brightness Set upper/lower limits Set time base Set signal averaging |
| F4: | Changes screen to MONITOR SETUP MENU
Select this option to: <ul style="list-style-type: none"> Set time & date Select D to A Adjust Current/Voltage Set serial port parameters |

3.2.3 Sensor Setup - By Pressing **F1** from Main Menu

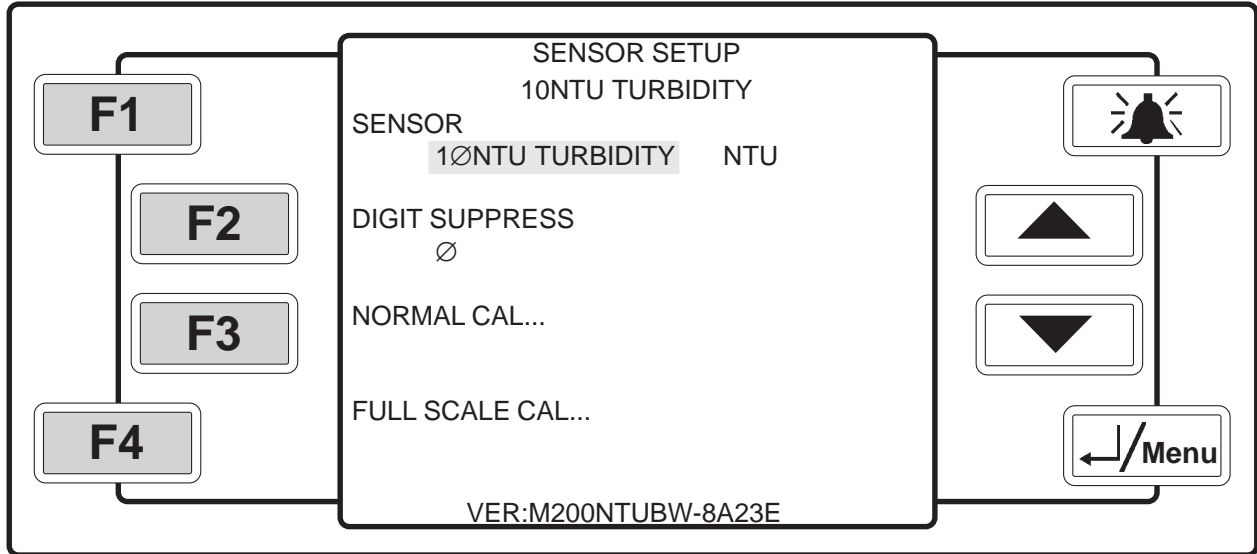

This is the Sensor Setup menu. As shown above, the cursor is highlighting 10 NTU Turbidity when you enter this menu. This parameter can be changed to 100 NTU Turbidity or Backwash. Note: Backwash only functions if you purchased the optional backwash hardware. To highlight the different parameters in the same row, use the "F" key to the left of the row you want to change. When a parameter is highlighted with the cursor, it can be changed using the keys.

By pressing **F1** in Sensor Setup. - **Turbidity/Backwash**

In this menu you can choose whether you want to display the Turbidity unit in NTU or Backwash unit to %T. Use the keys to change it for your requirements.

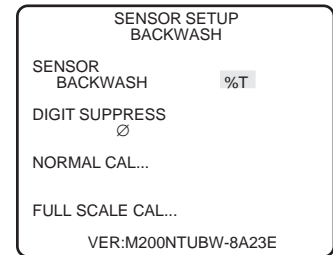
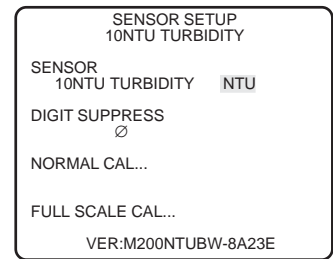

By pressing **F2** in Sensor Setup menu. - **Turbidity**

In this menu you can suppress or hold the least significant digits to zero. Selections of 1 digit, 2 digits or none may be selected using the key.

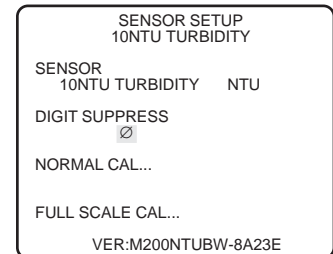

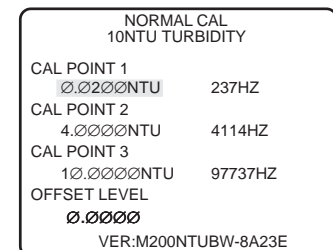

By pressing **F3** in Sensor Setup menu. - **Turbidity**

This is the turbidity calibration menu for the 0-10NTU Range. The Cal point is highlighted, but cannot be changed.





3.2.3 Sensor Setup - Continued

To perform calibration on any cal point, move the cursor using the appropriate "F" key to highlight the Hz column and then push one of the   keys.

By pressing  in Normal Cal... menu. - **Turbidity**

NORMAL CAL 10NTU TURBIDITY	
CAL POINT 1 0.0200NTU	237HZ
CAL POINT 2 4.0000NTU	4114HZ
CAL POINT 3 10.0000NTU	97737HZ
OFFSET LEVEL 0.0000	
0.0000 NTU	0HZ

By pressing  in Normal Cal... menu. - **10 NTU Turbidity Only**



In this menu you can offset the NTU value on the measurement screen to compensate for variations between process NTU readings and grab sample readings measured on a known good instrument. Offset adjustment is limited to ± 0.1 NTU in 0.01 NTU increments. Use the   keys to adjust the offset level to meet your requirements.

NORMAL CAL 10NTU TURBIDITY	
CAL POINT 1 0.0200NTU	237HZ
CAL POINT 2 4.0000NTU	4114HZ
CAL POINT 3 10.0000NTU	97737HZ
OFFSET LEVEL 0.0400	
0.0000 NTU	0HZ

By pressing  in Sensor Setup menu. - **Backwash**

NORMAL CAL BACKWASH	
CAL POINT 1 100.0%T	10.000HZ
90.0% T	9000HZ

By pressing  in Sensor Setup menu. - **10 NTU Turbidity Only**

Press  to perform a full scale calibration. In this menu a full scale calibration of the instrument can be done using a 10 NTU standard. Simply put the 10 NTU standard in the sensor and push the  key to perform the calibration.

EXTENDED SETUP 10NTU TURBIDITY	
FULL SCALE CAL...	
VER:M200NTUBW-8A23E	

FULL SCALE CAL 10NTU TURBIDITY	
PUT STANDARD IN SENSOR	
CAL TIME PRESS UP TO CALIBRATE	
6.9327NTU	6933 HZ

3.2.4 Alarm Setup - By Pressing **F2** from Main Menu

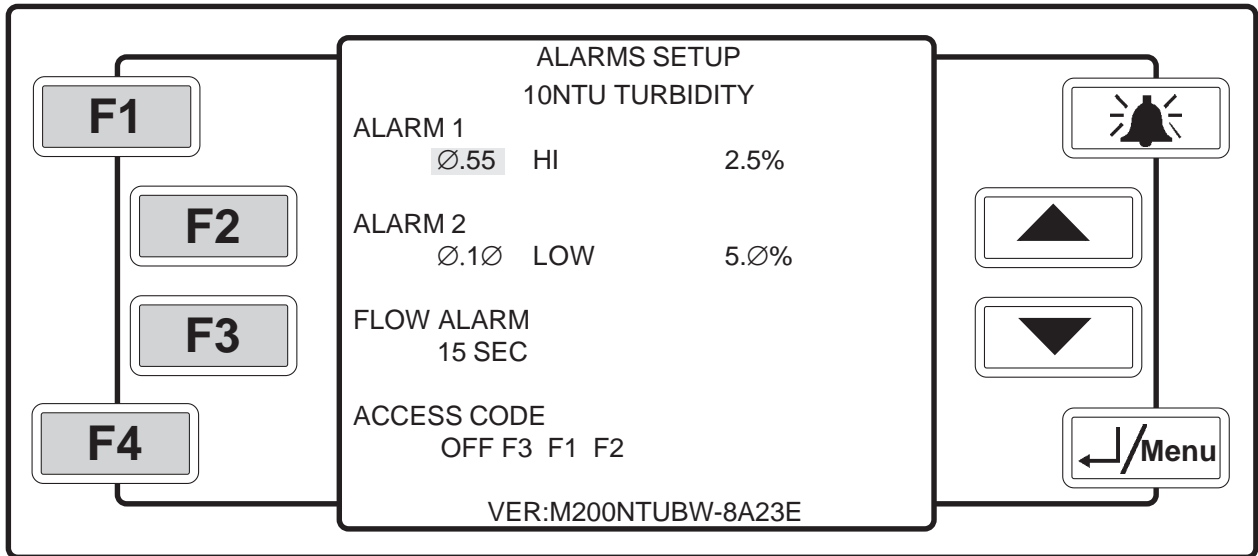

This is the Alarm Setup menu. The left side of the screen shows the selections described below. The main screen shown above, shows the current settings. To highlight the different parameters in the same row, use the "F" key to the left of the row you want to change. When a parameter is highlighted with the cursor, it can be changed using the keys. As soon as you enter this screen the alarm1 trippoint is highlighted and can be changed if required.

IN THE EXAMPLE ABOVE: *Alarm 1* is set to 0.55 NTU and the alarm state will change above 0.55 NTU. The deadband is set to 2.5%. *Alarm 2* is set to 0.10 NTU and the alarm state will change below 0.10 NTU. The deadband is set to 5.0%. The *Flow Alarm* is set to 15 seconds. Access Code is off, but it is set to F3 F1 F2.

By pressing **F1** in Alarm Setup menu. - **Turbidity/Backwash**

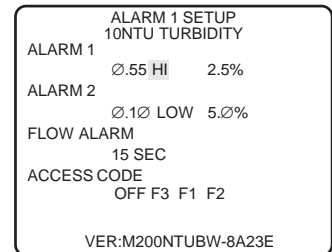

In this menu you can set Alarm 1 Off, Low or turn it Hi as shown. Use the keys to change it for your requirements.

By pressing **F1** in Alarm Setup again. - **Turbidity/Backwash**

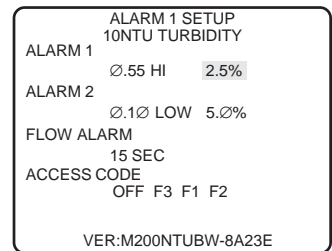

In this menu you can set the deadband value of Alarm 1 to 2.5%, 5% or 10%. Use the keys to change it for your requirements.

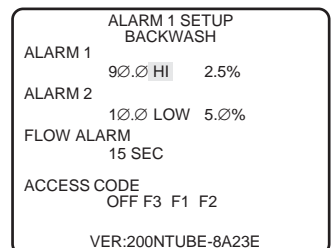

Alarm 2 Setup is exactly the same as Alarm 1. Press **F2** to change it for your requirement. When a parameter is highlighted with the cursor, it can be changed using the keys.

Shown is an example of Alarm 1 Setup in Backwash mode. The alarm point and deadband can be changed to fit your requirements as described above for Turbidity.



3.2.4 Alarm Setup - Continued

By pressing **F3** in Alarm Setup Menu. - **Turbidity/Backwash**

In this menu you can see the Flow Alarm Retention Time, which is the time required before the Analyzer will acknowledge the alarm with a blinking "FLOW AL!" error message on the measurement screen. This is also the retention time to return to normal operation. The retention times available are 15 sec, 90 sec, 180 sec or OFF. Use the   keys to change it for your requirements.

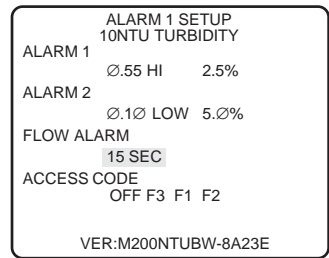

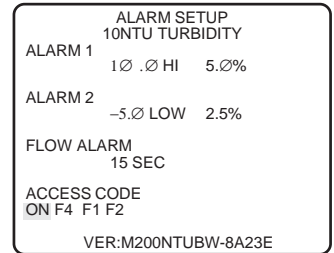

By pressing **F4** in Alarm Setup menu. **Turbidity/Backwash**

In this menu you can set the access ON or OFF. Use the   keys to change it for your requirements.



By pressing **F4** in Alarm Setup Menu again.

In this menu you can set a particular access code, so only plant personnel with a need to change system parameters can gain access to the system menus. Once one of the three "F" keys are highlighted, use the   keys to change the code to fit your requirements. You can set each "F" key shown as F1, F2, F3 or F4.

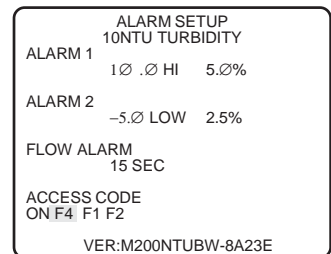

3.2.5 Display Parameters - By Pressing **F3** from Main Menu

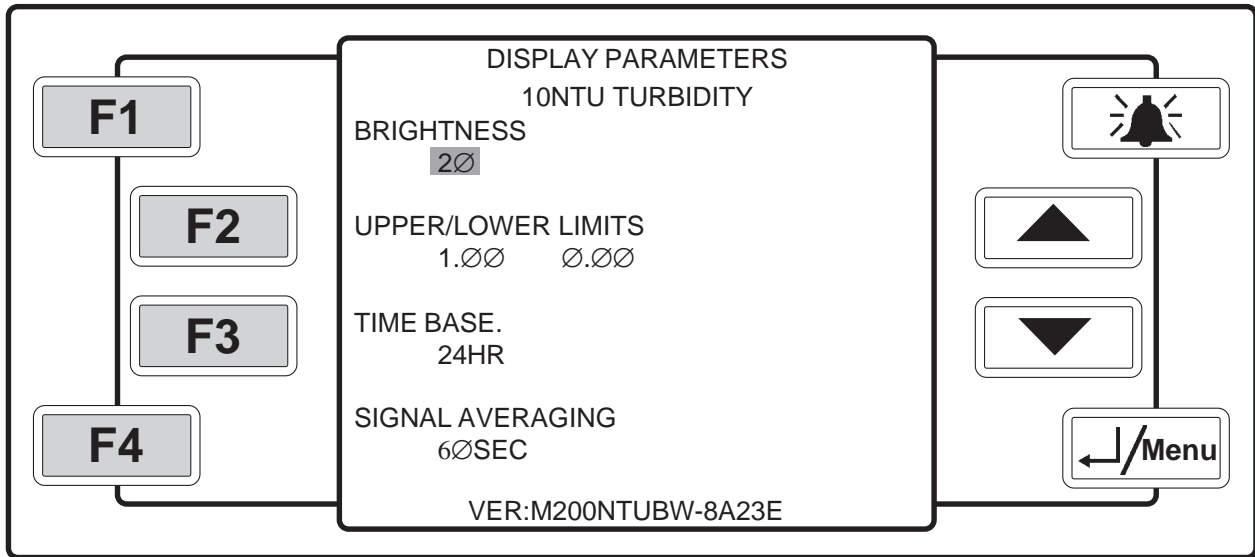

This is the Display Parameters menu. The left side of the screen shows the selections described below. The main screen shown above, shows the current settings. To highlight the different parameters in the same row, use the "F" key to the left of the row you want to change. When a parameter is highlighted with the cursor, it can be changed using the keys. As soon as you enter this screen the brightness is highlighted and can be changed if required using the keys.

IN THE EXAMPLE ABOVE: The *Brightness* is set mid-scale at 20 units. The *Upper/Lower Limits* of the graph on the measurement display are set to 1.00 and 0.00. The *Time Base* of the graph is set to 24 hours. *Signal Averaging* is set to 60 Sec.

By pressing **F2** in Display Parameters menu. - **Turbidity**

In this menu you can change the upper limit of the display graph from +0.10 NTU to +11.00 NTU. You can change the lower limit of the display graph from 0.00 to 10.90 NTU. Use the keys to change it for your requirements. By pressing **F2** again, the lower limit of the display graph can be highlighted. These two points establish the area of interest for the 4-20 mA or Voltage outputs.

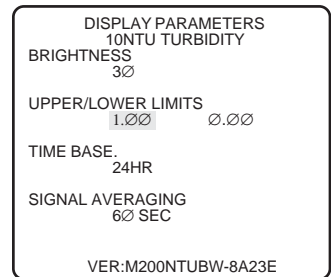

By pressing **F2** in Display Parameters . - **Backwash**

In this menu you can change the upper limit of the display graph from 100.0 NTU to 1.00 NTU or you can change the lower limit of the display graph from 0.0 to 99.0. Use the keys to change it for your requirements. By pressing **F2** again, the lower limit of the display graph can be highlighted.

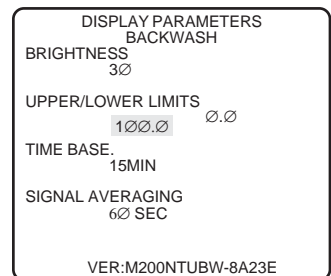

By pressing **F3** inside the Display Parameters menu. - **Turbidity**

In this menu you can change the Time Base, which establishes the time increments on the measurement graph. There are two time bases available, 1HR and 24 HRS. Use the keys to change it for your requirements.

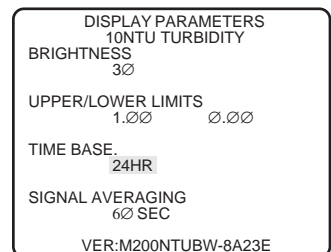



3.2.5 Display Parameters - Continued

By pressing **F3** inside the Display Parameters menu. - **Backwash**

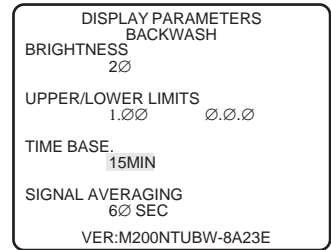
In this menu the time base, which establishes the time increments on the measurement graph can be highlighted, but there is only one time base available, 15MIN.



By pressing **F4** inside the Display Parameters menu. - **Turbidity/Backwash**

In this menu you can change the Signal Averaging period. Normally readings are updated at a rate of once per second. A higher averaging time will give smoother curves to the graphical display and to recording devices and helps "wash out" anomalies. Averaging times of 15 sec., 30 sec, 60 sec. or OFF are available. Use the   keys to change it for your requirements.

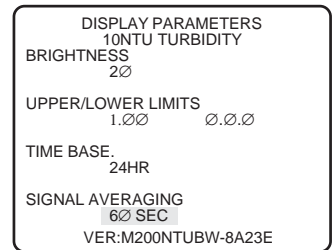

3.2.6 Monitor Setup - By Pressing **F1**

from Main Menu

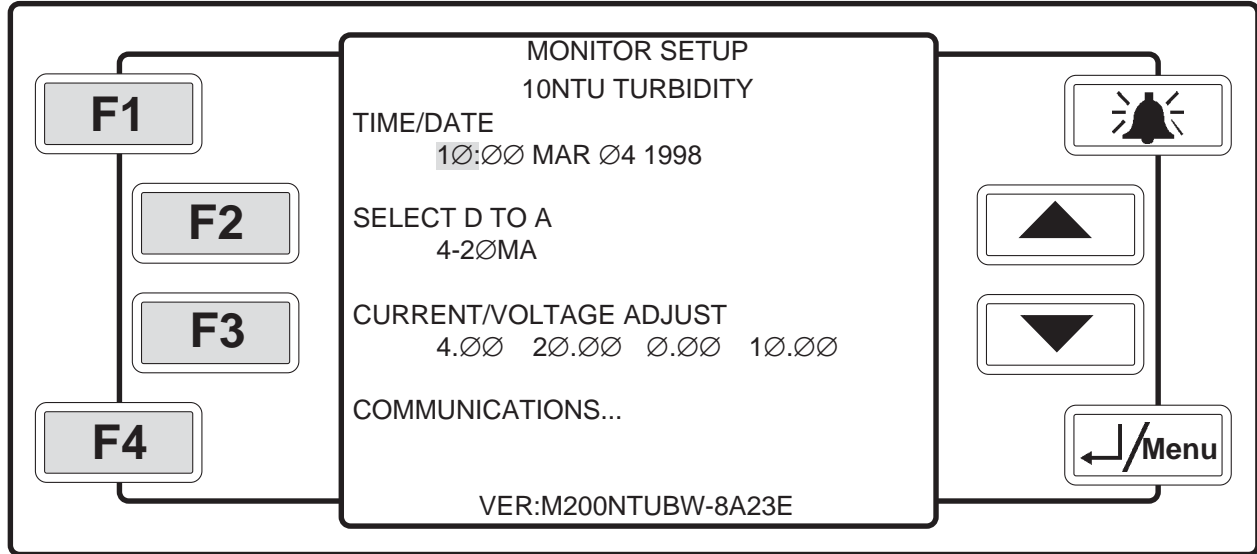

This is the Monitor Setup menu. The left side of the screen shows the selections described below. The main screen shown above, shows the current settings. To highlight the different parameteres in the same row, use the "F" key to the left of the row you want to change. When a parameter is highlighted with the cursor, it can be changed using the keys. As soon as you enter this screen the hour time increment is highlighted and can be changed to local time, if required, using the keys.

IN THE EXAMPLE ABOVE: The *Time/Date* is set to 10 hours 00 minutes, in 24 hour clock mode, and the date is set to March 04, 1998. The analog output signal (*Select D to A*) is set to 4-20mA. The *Current/Voltage Adjust* is set to default conditions.

By pressing **F1** in Monitor Setup menu.

In this menu the minute time increment can be changed to local time, if required, using the keys. The clock accepts the new time and date when you press .

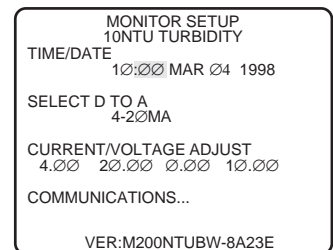

By pressing **F1** again.

In this menu the month can be changed, if required, using the keys. The next menu allows the day to be changed, if required. *This screen is not shown.*

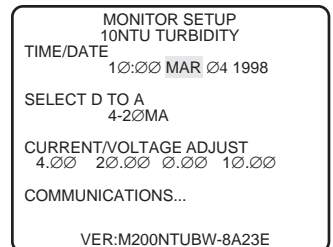

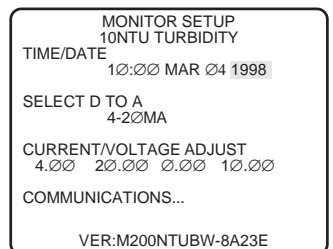

By pressing **F1** once again.

In this menu the year can be changed using the keys. The complete date is accepted when you press .





3.2.6 Monitor Setup - Continued

By pressing **F2** in the Monitor Setup menu.

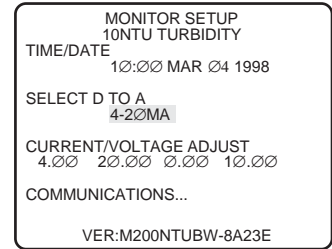
In this menu the digital to analog converter can be set to output a 4-20mA signal or a 0-10 Volt signal using the   keys. The D to A automatically calibrates to the upper and lower limits you selected in the Display Parameters menu.



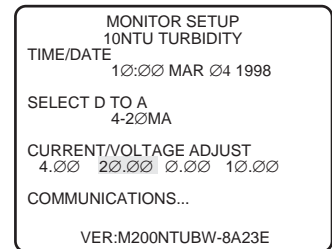

By pressing **F3** in Monitor Setup menu.

In this menu the 4-20mA output can be fine tuned to your requirements. You can change either end or both ends of the 4-20mA output, using the   keys. Only the 20mA end of the scale is highlighted here. *The menu highlighting the 4mA end is intentionally not shown.*



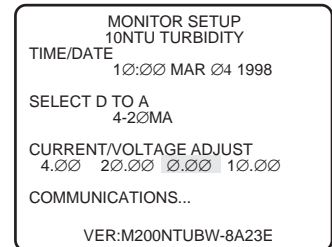

By pressing **F3** again.

In this menu the 0-10 volt output can be fine tuned to your requirements. You can change either end or both ends of the 4-20mA output, using the   keys. Only the volt end of the scale is highlighted here. *The menu highlighting the 10 volt end is intentionally not shown.*





The following menus will have no purpose *unless* you have one of the optional serial ports installed.

By pressing **F4** in the Monitor Setup menu.

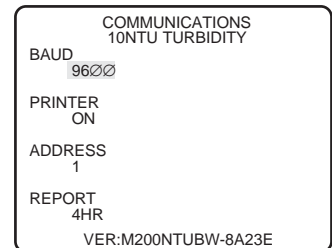
In this menu the baud rate can be changed to meet your requirements using the   keys. Baud rate of 300, 600, 1200, 2400, 4800 or 9600 may be selected.



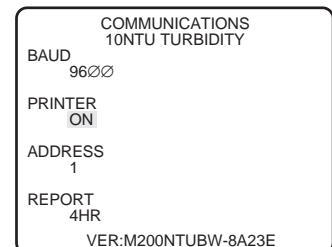

By pressing **F2** in the Communications menu.

In this menu the serial printer mode can be turned On or Off. If the printer is selected On and report is Off then the serial port will output the current reading in real time which is an update to the output every second. Choose this mode if your sending the data directly to a data logger or other data collection device. You can change the printer to On or Off by using the   keys.





3.2.6 Monitor Setup - Continued

By pressing **F3** in the Communications menu.

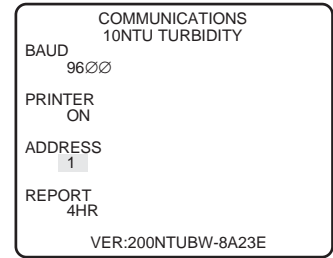
In this menu an address may be assigned to a particular instrument. You may select the address from 0 to F, Hexadecimal by using the   keys.



By pressing **F4** in the Communications menu.

In this menu you can select two time periods that a report can be sent to the printer. You can choose a report every four hours or every 24 hours. If the printer option above is turned On and either report time is selected, the report will be printed at the interval selected. If both printer and report are Off then no output data will be available. You can change the report selection by using the   keys.

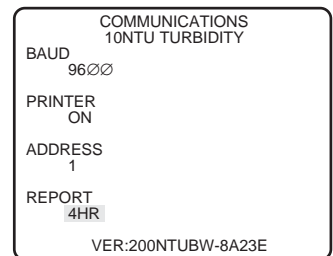

3.2.7 Backwash Display

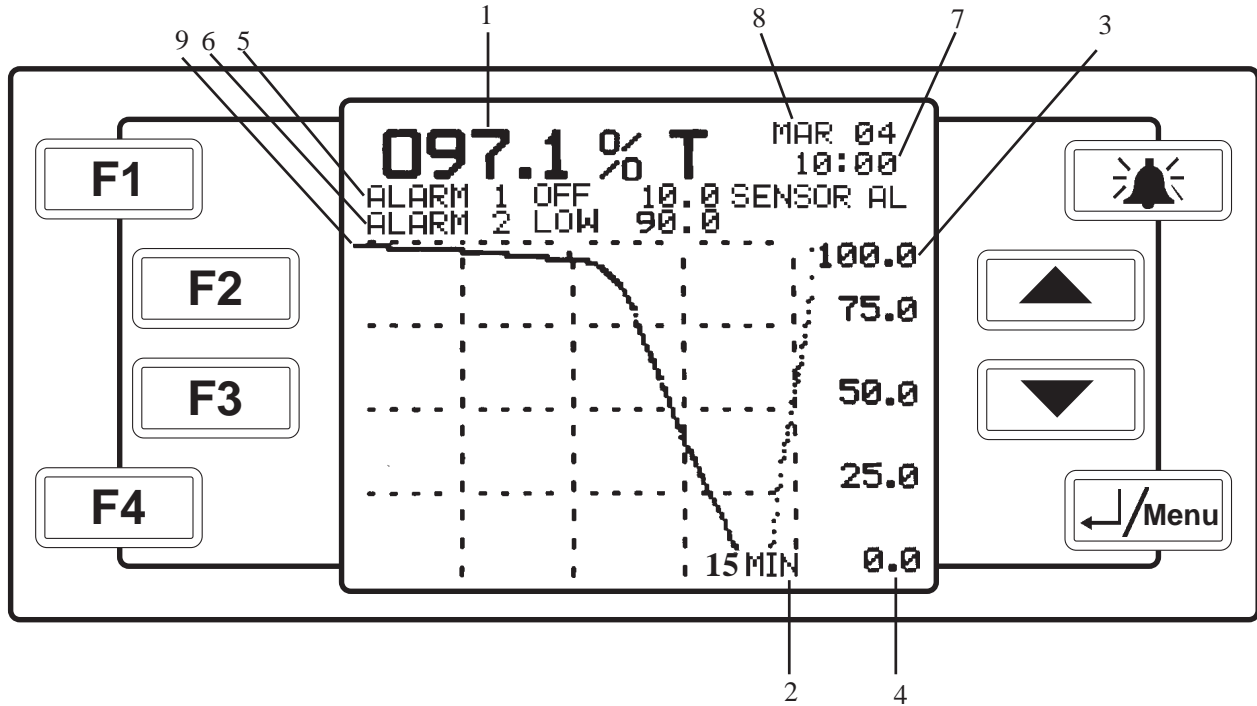

This is the backwash display. It is only meaningful if the Backwash option is connected. The screen above shows a typical backwash cycle. In this mode, updates are made to the screen every 6 seconds. The reading is updated every second. The display shows the following parameters:

- 1 - CURRENT %T READING: 97.1 %T
- 2 - GRAPH TIME BASE: 15 MINUTES
- 3 - GRAPH UPPER LIMIT: 100 %T
- 4 - GRAPH LOWER LIMIT: 0 %T
- 5 - ALARM 1 SETTING: ALARM SET AT 10%, BUT TURNED OFF
- 6 - ALARM 2 SETTING: ALARM ON LOWER THAN 90.0 % T
- 7 - TIME: 10:00 AM (SHOWN IN 24 HOUR CLOCK MODE)
- 8 - DATE: MARCH 4
- 9 - GRAPH OF BACKWASH HISTORY (with optional Backwash Sensor and Interface connected)

To leave the backwash display and get to the Main Menu push  . F1 - F4 are nonfunctional in this display.

3.3 START UP

Before placing the MICRO 200 BW on line we recommend that you standardize the instrument. The following sections describe the required procedures.

3.3.1 Indexing

The United States Environmental Protection Agency (U.S. EPA) recommends that cuvettes used for instrument calibration or sample measurement be indexed.

To comply with U.S. EPA standards, the MICRO 200 BW includes an Indexing Ring for quick and repeatable indexing of the reference standard.

To index the calibration standard you must be in the calibration menu. Observe the center (current frequency) reading while performing the following steps:

- Slowly rotate the standard, inside the optical well, one complete revolution (360°). While rotating the standard slowly, observe the measured turbidity and locate the position of the cuvette having the lowest reading.
- With the calibration standard positioned at the location having the lowest turbidity reading, install the Indexing Ring over the cap on the standard so that the pointer of the Indexing Ring faces directly forward.

When using the standards in the future, always insert the standard so that the pointer of the indexing ring faces forward. Slowly rotate the standard back and forth about 5° to find the lowest point. The standard is now indexed and ready for use.

Figure 10 shows a calibration standard being indexed.

NOTE: This Calibration Standard is only Indexed to the Turbidimeter for which it was aligned.

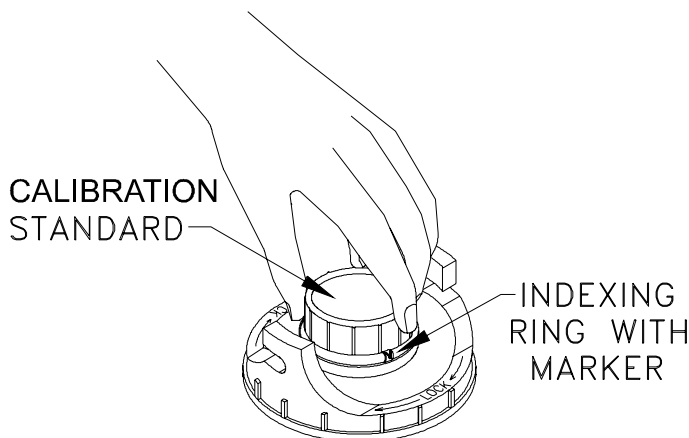

Figure 10
Calibration Standard Indexing

3.3.2 Standardizing

The calibration standard (cuvette) supplied with the MICRO 200 BW is a pure liquid sealed in glass. It has a value of 0.02 NTU.

Standardization is performed in the calibration menu see page 15 & 16 for more details. While in the calibration menu perform the following operations:

- Place the Calibration Standard in the Optical Well.
- Index the Calibration Standard as previously described.
- Allow a few seconds for the standard to stabilize.
- Press the F1 button to accept the frequency.

NOTE: This operation “calibrates” the .02 NTU calibration standard in the range of interest. If both ranges maybe used this operation should be performed on both ranges.

CAUTION: Avoid scratching the surface of the cuvette. Keep the cuvette surface clean and free of dust. A scratched or dirty and dusty cuvette will cause analysis error. For instructions (See: V. ROUTINE MAINTENANCE).

4.0 ROUTINE OPERATION

4.1 CONTINUOUS MONITORING FLOW THROUGH UNIT

The standard flow through unit supplied with the instrument is designed to operate at pressures up to a maximum of 60 p.s.i. (414 kPa or 4.22 kg/cm³) and temperatures to a maximum of 122° F (50° C) fluid temperature. Flow rates through the unit can be adjusted from 0.5 gpm (200 ml/min) to a maximum of approximately 1.5 gpm (5.7 liters/minute). The speed of sensing turbidity changes will depend on the length of the takeoff line, the diameter of the takeoff line, and the flow rate or velocity through the takeoff line. By using a high flow rate and keeping the lines small, approximately 3/16 inch (4.8 mm) I.D. and relatively short length, the response time is kept to a minimum. Consult HF scientific, inc. when unusually long connections are required.

Depending on the type of fluid being monitored, a pressure drop through the line can cause gas or air to come out of solution and form bubbles which will create errors in the turbidity measurements. This can be prevented by creating a slight back pressure on the

discharge side of the flow through unit using the backpressure valve (Catalog #24008) supplied. Increasing the size of the incoming line will also help this condition.

NOTE: Since each application is different, the amount of back pressure required to eliminate bubbles must be determined and modified on site during operation by the customer.

A plastic shut-off clamp is provided on the inlet side of the flow through unit in order to completely stop flow to facilitate changing the cuvette. See the section on cuvette cleaning and care for more information.

The U.S. EPA recommends that cuvettes used for instrument calibration, standardization, or sample measurement be indexed. For quick indexing of the flow through cuvette, a rotational flow through assembly with locking collar is supplied.

To index your flow through cuvette, slowly rotate the flow head through at least one revolution, while observing the reading, to locate the position of the lowest reading. Without moving the flow through, press down on it and turn the locking collar until the flow through assembly is securely locked in place. See figure 11.

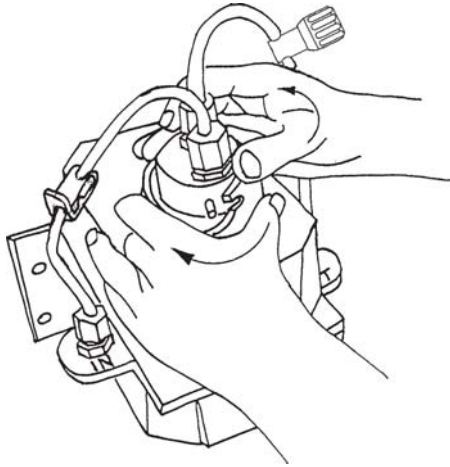

Figure 11
Flow Through Cuvette Indexing

4.2 VAPORPURGE

The MICRO 200 BW is equipped with a continuous vaporpurge system. A fan inside the sensor continuously circulates heated, dry air around the optical well and the flow through cuvette. This feature eliminates the need for connection of a dry purge line. See Figure 12.

The humidity indicator card is blue when dry and turns to a light pink when the desiccant is expended. Check

the desiccant on a quarterly basis or if after cleaning the cuvette readings appear erroneously high to ensure proper operation of the vaporpurge feature. **It is important to keep a cover on the sample well if the flow through head is out for more than a few minutes, to avoid saturating the desiccant uselessly.** A replacement desiccant pouch is available from HF scientific or your local representative HF part# 21555R. See figure 1 on page 6 when replacing the desiccant.

Remember to dry the flow through cuvette of excess moisture before inserting it into the optical well. This will speed up the evaporation time.

NOTE: If it should become necessary to return the sensor to the factory, you need only return the upper sensor assembly and not the base. IF RETURNING THE BASE, THE DESICCANT TRAY SHOULD BE REMOVED AND STORED IN A ZIP LOCK BAG BEFORE SHIPPING.

4.3 GRAB SAMPLES

Take extreme care when handling any sample cuvettes. Surface scratches, dust or finger smudges will cause analysis error. Examine each cuvette carefully before the sample is drawn and placed in the Optical Well. We recommend that the cuvette be wiped clean with a lint-free laboratory tissue before the sample is drawn. Handle Reference Standard and cuvettes by the top portion only.

To take a reading of a grab sample:

1. Set Averaging to 1 second (see page 19).
2. Remove the flow through unit and insert grab sample cuvette in Optical Well.
3. The turbidity value of the grab sample will now be displayed on the readout. Allow at least two updates (five to ten seconds) for best accuracy before noting the reading.

NOTE: Settling particles or air in the sample may cause the digital reading to “hunt”. For best results take readings before turbid particles settle but after air bubbles have been allowed to escape.

5.0 ROUTINE MAINTENANCE

5.1 CUVETTE CLEANING & CARE

Cuvettes must be clean and free of marks or scratches in the critical area (see figure 13 on page 28). Cleaning is accomplished by washing the interior and exterior of the cuvette in a detergent solution, then rinsing thor

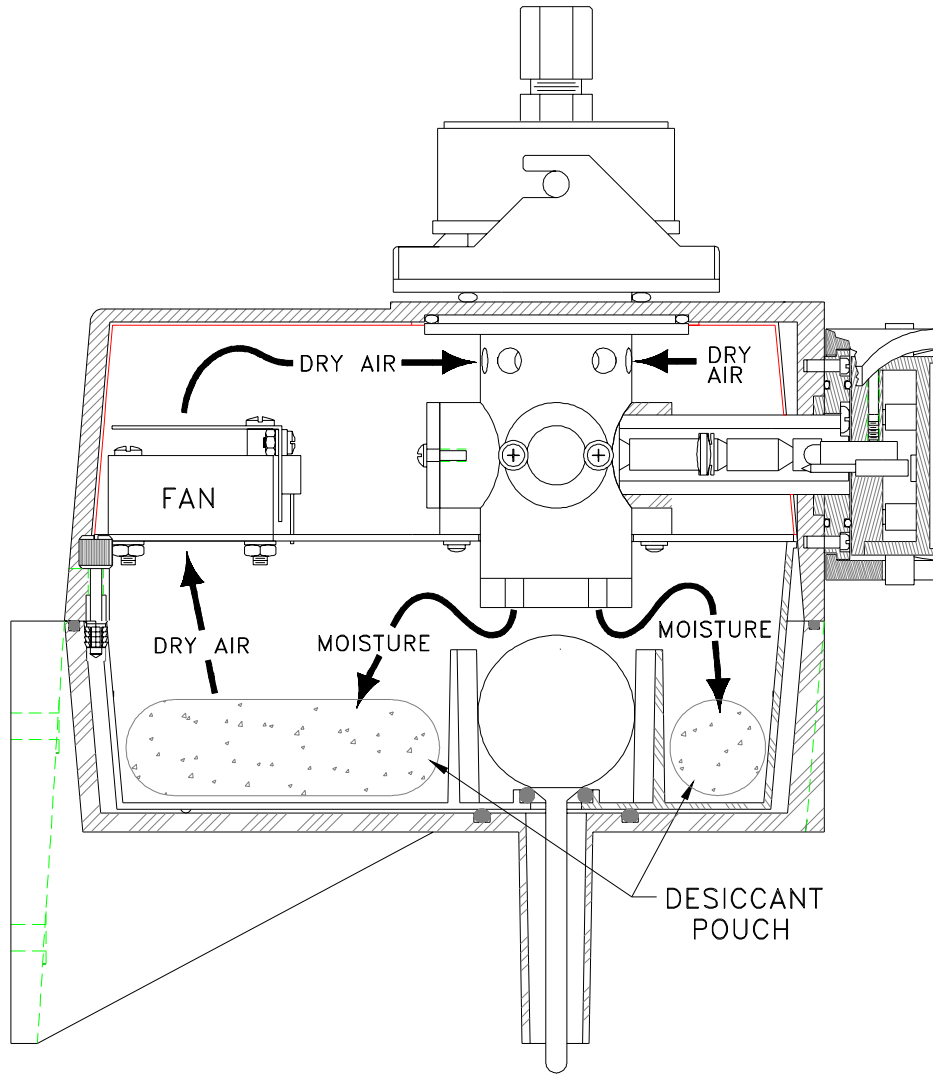

Figure 12
Vaporpurge

oughly 8 to 10 rinses in clean, distilled water, to remove all streaks.

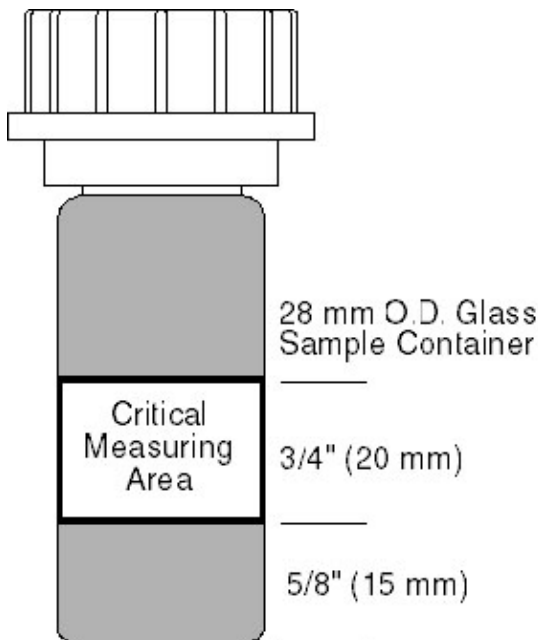

Figure 13
Critical Measurement Area

The sample flow must be shut off, with the shut-off clamp on the inlet flexible tubing, when the cuvette in the flow through unit is to be cleaned or changed (see figure 14).

Replace the cuvette if scratches or marks in the critical area affect readings.

Store reusable cuvettes (Catalog No. 50036, pkg of 3) in a clean dust-free environment.

5.2 LAMP REPLACEMENT

Periodically the LAMP MODULE, Cat. #21541, in the sensor will require replacement. It is recommended that one spare lamp for each MICRO 200 BW be kept on hand at all times. A burned out lamp is indicated by a flashing SENSOR AL indicator on the analyzer display. **TO CHANGE THE LAMP MODULE SIMPLY TURN THE OUTSIDE LOCKING RING COUNTER CLOCKWISE, AND PULL THE MODULE STRAIGHT OUT.** Reverse the procedure to install the replacement module. For accurate operation a complete calibration is recommended after a lamp module replacement. See page 29 for calibration instructions. Refer to figure 14.

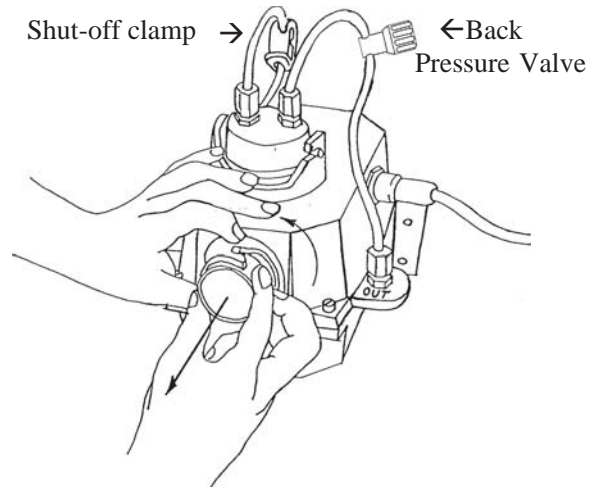

Figure 14
Lamp Replacement

5.3 CALIBRATION PROCEDURES

5.3.1 Calibration Standards

5.3.1.1 **PRIME TIME** Standard Set (optional) Catalog No. 19820

HF **PRIME TIME** Primary Standards are recommended and certified by HF scientific. They are more stable than Formazin and have a minimum shelf life of 12 months. These standards are very easy to use off the shelf anytime without preparation making them an ideal turbidity standard. A Certificate of Traceability is available on request to HF scientific Customer Service Department. Prior to calibration, review the expiration dates, to ensure that the standards have not expired. Order from HF scientific, inc.

NOTE: Do not freeze standards. Do not leave standards in the measuring well for extended periods. Do not shake standards.

Each **PRIME TIME** Primary Standard Kit contains:

- 0.02 Calibration Standard
- Certified Primary Standards 4.00, 10.00, 40.00, 100.00 NTU Standards are contained in preselected cuvettes with light shield caps.
- A sturdy storage case

5.3.1.2 Standard Formazin Solutions

We recommend that this instrument be calibrated on the factory prepared **PRIME TIME** primary calibration standards to achieve the stated accuracy.

It is well known that diluted Formazin is unstable. If Formazin is used to calibrate the instrument ensure that a fresh stock suspension is used. Formazin stock suspension can be prepared by the user (Reference Standard Methods For Examination of Water and Wastewater) or a kit can be purchased from, HF scientific, inc., Catalog No. 50040.

NOTE: When the prepared samples start to flocculate, they are unreliable and fresh ones must be made. This will occur more rapidly for the lower value diluted suspensions.

5.3.2 Calibration Steps 0-10 NTU Range (Also See Section IV)

To meet stated accuracy it is advisable to allow both the analyzer and sensor to come to its optimum operating temperature, which can take approximately two hours. After this point you can proceed with the following procedure.



Standardization should be performed after 10 NTU (Full Scale) Calibration, although it is possible to standardize at any time without performing a complete calibration.



Although it is possible to calibrate at any combination of the calibration points, to achieve the stated accuracy use the following procedure.

Read these instructions in entirety prior to calibration. Select Extended Setup menu then:

1. Insert 10 NTU Standard
2. Rotate the standard while observing the frequency until the lowest reading is noted.

NOTE: Be prepared for the two least significant digits to move about, this is normal.

3. (Full Scale) calibrate the instrument with the 10 NTU Standard by pressing the F2 key to highlight "Press Up to Calibrate". Then press the  key.
4. A full scale calibration is performed which adjusts the maximum gain of the instrument. The NTU value and frequency are displayed on the lower edge of the screen.
5. Press the  key twice to return to the Sensor Setup menu.
6. Select  Normal Cal...
7. Press the F3 key twice to highlight the frequency for Cal Point 3.



8. Press the . The frequency at the time of the selection is saved as the calibration frequency for the 10 NTU standard. This frequency is displayed in the right hand column.
9. Insert the 4 NTU standard.
10. Rotate the standard while observing the frequency until the lowest reading is noted.
11. Press the F2 key twice to highlight the frequency for Cal Point 2.
12. Press the . The frequency at the time of the selection is saved as the calibration frequency for the 4 NTU standard. This frequency is displayed in the right hand column.
13. Insert the .02 NTU Calibration Standard.
14. Rotate the Calibration Standard to its index point. If the standard has not been indexed, see page 25.
15. Press the F1 key twice to highlight the frequency for Cal Point 1.
16. Press the . The frequency for the 0.02 NTU standard is saved. This frequency is displayed in the right hand column.

5.3.3 Calibration Steps 0-100 NTU Range (Also See Section IV)

To meet stated accuracy it is advisable to allow both the analyzer and sensor to come to its optimum operating temperature, which can take approximately two hours. After this point you can proceed with the following procedure.



Read these instructions in entirety prior to calibration. Select calibration menu then:



1. Insert 100 NTU Standard
2. Rotate the standard while observing the frequency until the lowest reading is noted.
3. Press the F3 key twice to highlight the frequency for Cal point 3.
4. Press the  key. The Frequency at the time of this selection is saved as the calibration frequency for the 100 NTU standard. This frequency is displayed in the right hand column.
5. Insert the 40 NTU standard.
6. Rotate the standard while observing the frequency until the lowest reading is noted.
7. Press the F2 key twice to highlight the Frequency for Cal Point 2.

8. Press the . The Frequency at the time of this selection is saved as the calibration frequency for the 40 NTU standard. This frequency is displayed in the right hand column.
9. Insert the Calibration Standard.
10. Rotate the Calibration Standard to its index point. If the standard has not been indexed, see page 25.
11. Press the F1 key twice to highlight the frequency for Cal point 1.
12. Press the . The frequency for the 0.02 NTU standard is saved. This frequency is displayed in the right hand column.

6.0 SECURITY ACCESS CODE

The security access code for the MICRO 200 BW provides a degree of protection against an unauthorized change to the instrument's settings or parameters. The security code feature may be turned off if desired.

The first requirement for the security access code after "power-up" is when you wish to exit the current display screen (turbidity or backwash). Upon pushing the  button to leave the display screen, a request will be made for the security access code. If the wrong code is entered, the screen will return to the previous display after pressing . About ten seconds are allowed to enter the correct security access code. After this time the screen will return to the previous display. **Security access codes may be entered using the F1, F2, F3 or F4 keys only.**

Your personal code may be recorded and used for general maintenance. This code may be changed at any time. To record another code, go to the ALARM SETUP MENU. Press the F4 button to highlight the "F" key you wish to change. Use the   keys to change the code to fit your requirements. To use the access code feature, toggle the access code to on. Note that the security access code must be any combination of four function buttons, F1 through F4. See page 18. Push the button to accept this code. 

7.0 TROUBLESHOOTING

7.1 GENERAL NOTES

Service and technical support are available from the manufacturer, HF scientific inc. from 8:00 AM to 4:00 PM Eastern Standard Time.

The following Table will supply fundamental troubleshooting information. The Guide assumes that the controls and functions of the instrument are used correctly. The intention of the guide is to eliminate common faults, not to troubleshoot down to component level.

GUIDE TO FUNDAMENTAL TROUBLESHOOTING

SYMPTOM	SOLUTION
Display not lit.	<ol style="list-style-type: none"> 1. Make sure that the unit is plugged in and turned on. Make certain that your power source is providing the correct voltage. 2. Check analyzer fuse. Refer to page 7 for correct fuse size and instructions for changing. 3. Shut off power for about five seconds and then turn it back on. This will initiate a power on reset. 4. If none of the above steps correct the problem, contact HF scientific, inc. service dept. for additional support.
Instrument not functioning correctly.	<ol style="list-style-type: none"> 1. If sensor cable was removed from the analyzer, check wiring connections.
Cannot leave menu.	<ol style="list-style-type: none"> 1. Invalid parameters may have been inadvertently set. Examples of this are a bad time or date or the lower limit set higher than the upper limit. Check the screen and change any invalid numbers.
Display response slow.	<ol style="list-style-type: none"> 1. Select a lower averaging time.
Sensor alarm on.	<ol style="list-style-type: none"> 1. Replace the lamp module. 2. Check the connection at the sensor. 3. The turbidity may be too high. If you are on the low range, switch to the higher range. 4. Replace the sensor. If you have a spare sensor or another MICRO 200 BW you may use the alternate sensor to determine if the sensor in question is defective.
Readings lower than expected.	<ol style="list-style-type: none"> 1. Recalibrate with known good standards.
Readings higher than expected.	<ol style="list-style-type: none"> 1. Check the flow through cuvette. If it has dirt on either the inside or outside or is scratched, clean the cuvette or replace it. 2. Check for condensation on the outside of the cuvette. If condensation is present either the desiccant tray needs replacement or the vaporpurge system of the sensor is defective. Replace the desiccant or the sensor. 3. Recalibrate the sensor with known good standards.
Readings erratic.	<p>To check if the erratic readings are due to sample measurement or a problem with the instrument, remove the flow through unit and place a light shield over the sample well. This may be left for a period of time and the graphic history observed later. If the graph shows instability the MICRO 200 BW has a problem. Call HF scientific service dept. If the graph is stable there is a problem with the sample being measured. See the following for suggested corrections.</p> <ol style="list-style-type: none"> 1. Check for debris in flow through cuvette. Clean out as required. 2. Increase back pressure with flow control valve. This will keep air in solution.
Analyzer Displays "Frequency Error"	<ol style="list-style-type: none"> 1. "0-10 range 10 NTU calibrate" should only be performed with a 10 NTU standard in sensor well.

7.2 SPARE PARTS LIST FOR MICRO 200 BW

<u>CATALOG NO.</u>	<u>DESCRIPTION</u>
20892	BNC Connector
50036	Cuvette (3 pk) 28 mm x 70 mm (pressure checked)
21555R	Desiccant Pack
50004	Flow control valve
50125	Flow through assembly
21512	Foot Valve Assembly
50040	Formazin Stock Solution Kit (4000 NTU)
21062	Kit, tubing & fittings Micro 200 Sensor
21541	Lamp Module
50092	Light Shield Cap
20853	NTU Sensor Cable (per foot)
19807	NTU Sensor Module, 0 - 10 & 0 - 100 NTU, Electronics portion only
21148	Nylon Bulkhead Assembly
50136	O-ring kit for flow through unit.
21652	Operating & Maintenance Manual
21870	PC Board Micro 200 BW Analyzer (Universal)
60002	Standard 0.02 NTU
20106	Stilling Chamber

OPTIONS - BACKWASH

19275	Backwash Interface
20849	Backwash Interface to Analyzer Cable
50321	Backwash Sensor
20853	Backwash Sensor to Interface Cable
19805	Junction Box
20848	Junction Box Extension Cable
50345	Backwash Sensor Extension Handle
50356	Backwash Sensor Extension Handle Mounting Installation Kit

HF scientific, inc.
Phone: (239) 337-2116
Fax: (239) 332-7643

8.0 OPTIONS

BACKWASH

8.1 INSTALLATION

8.1.1 Backwash Interface (Catalog No. 19275)

To monitor backwash using the MICRO 200 BW, one backwash interface and one backwash sensor is required for each analyzer. Refer to figure 16 for the outline of the backwash interface. Power requirements are 12 VA at 110 - 120 VAC or 220 - 240 VAC. The voltage may be changed using the selector switch located inside the interface housing. See figure 17 for details. The interface may be mounted up to 300 feet (91.4 m) away from the backwash sensor. The signal is sent to the MICRO 200 BW analyzer via BNC connectors through up to 1000 feet (304.8 meters) of coaxial cable (Catalog No. 20849). Refer to figure 15 for the analyzer BNC cable connection.

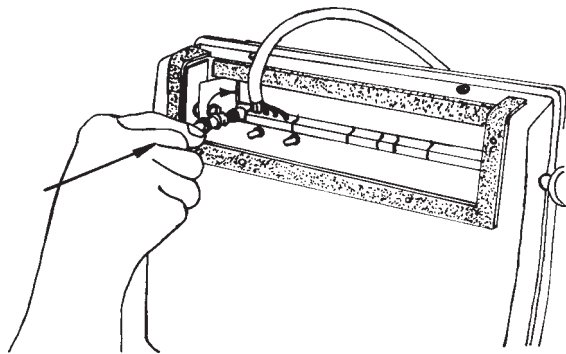

Figure 15
Analyzer BNC Connection

8.1.2 Junction Box

This option, HF Catalog No. 19805, may be used to extend the backwash sensor cable to a total length of 350 feet (106.7 meters), as measured from the sensor to the backwash interface. The junction box is weather tight and may be mounted outside. Refer to figure 18 for outline dimensions. For wire connections refer to figure 19. Extension cable may be ordered using HF Catalog No. 20848.

8.1.3 Backwash Sensor

There are two standard methods of installing this sensor, **channel mounting** and **extension handle mounting** (Catalog No. 50321). Both of these will be described below. If alternate methods of mounting are required, please consult HF scientific inc.

When choosing an installation site for the sensor there are several things to consider. Since filters rarely will backwash consistently or uniformly, a site should be chosen that best averages the backwash water over the cycle. The sensor should also be located as close to the backwash filter as possible to reduce the time delay of the water sample. This will give the operator a correct picture as to how the backwash is proceeding and when it is complete. Refer to figure 20 for sensor outline dimensions.

8.1.3.1 Channel Mounting

This method can be used when the area above the end of the channel is easily accessible. This allows cleaning of the sensor or calibrating by lifting the sensor up by its cable and lowering it back into place when you are finished. Since the sensor is not affected by sunlight, a light shield is not required. An installation kit is available from HF scientific, HF Catalog No. 50345 which includes the sensor chamber, a stainless steel bracket, and mounting clamps. The user must supply PVC piping, bolts and anchors. Refer to Figure 21.

8.1.3.2 Extension Handle Mounting

This method allows the user to adjust the sensor positioning to optimize the sampled water. An installation kit is available from HF scientific, HF Catalog No. 50356 which includes sensor end baffles, hose clamps, and a pipe adapter. The user must supply the extension pipe such as galvanized steel 1/2" to 1 1/2" in diameter (12.7 mm - 38.1 mm) and any additional mounting deemed necessary for upper end.

1. The slot for the outlet baffle must be positioned in a vertical axis at the top.
2. Remove all rough edges from the pipe to prevent cable damage.
3. Attach the sensor to the pipe adapter with hose clamps.
4. Sensor cable can be wrapped around the pipe. If the pipe diameter permits, the cable can be threaded through the pipe.
5. Don't pull the cable too sharply through the pipe, use a large radius bend instead.

In operation, some experimentation will be needed during backwash to achieve optimal results. Note that the adapter has a pivot to allow the sensor to lay parallel to the bottom. Refer to figure 22.

8.2 BACKWASH SENSOR CONNECTIONS

The Backwash sensor is supplied with a 30 foot (9.1 meters) cable (Catalog No. 20853). This cable connects at TB2 of the Backwash Interface. The cable should first be inserted through the strain relief fitting of the case. At

this point the outer jacket of the cable should be stripped back about three inches. Care must be used to not nick the wires under the jacket. Note that the sensor cable is composed of two pairs of wires. Each pair consists of two insulated wires and an uninsulated shield wire, wrapped individually in a foil shield. The wire pairs are RED & BLACK and WHITE & BLACK. The foil can be unwrapped and removed, while keeping the pairs together. The two shield wires should be wrapped together. The remaining wires need to have the insulation stripped back about ¼". The sensor cable can now be wired to the appropriate terminal block, using care not to transpose the black wires in opposite pairs. Make the following connections:

Terminal 1	White wire - white/black pair
Terminal 2	Black wire
Terminal 3	Uninsulated shields
Terminal 4	Red wire
Terminal 5	Black wire - red/black pair

8.3 BACKWASH SENSOR MAINTENANCE

Over a period of time contaminants may build up on the flow through glass surface of the sensor. This may affect the operation of the sensor. The sensor should be cleaned periodically. A soft bottle brush can be used with a mild solution of water and detergent followed by a thorough rinsing with water. For optimal results, clean the sensor each time before calibrating.

An indicating type desiccant can be seen through the glass of the sensor. If no leaks are present, these beads will be blue. If the beads are not blue, the sensor must be returned to HF scientific for service.

8.3.1 Backwash Calibration

This procedure takes place through the Calibration selection from the Utilities Menu. Numbers will be displayed on the LCD (screen). These numbers represent frequencies adjusted so that 10KHz is represented as 100%T. The numbers in the top center of the screen show real time frequency and percent transmittance as it is output from the sensor. The number to the right of the 100%T is the frequency that was saved from the previous backwash calibration. See page 16.

Follow this procedure:

1. Inspect the glass tube in the backwash sensor. Clean the sensor in mild detergent and a soft bottle brush, if required.
2. Insert the backwash sensor in a container of

100 %T water, preferably the same water which will be used for backwash.

3. Press the **F1** twice to highlight the Frequency Column. Press the **▲** to perform calibration. (This is the only cal point necessary for backwash calibration.)

8.4 BACKWASH ALARMS

To use the backwash alarms you must first enter the backwash display, and then exit to the main menu. Select F2 for alarms. The alarms may be set as shown on page 17. Note that the alarms are set in percent transmittance and that these alarm settings are unique to the backwash function. These settings do not affect previous turbidity alarm settings.

CAUTION: If either of these alarm contacts are wired to a turbidity control function, set that alarm to "off" to prevent accidental operation during a backwash. Likewise, if alarm contacts are wired to a backwash control function, set that alarm to "off" to prevent accidental operation during turbidity measurement.

8.5 BACKWASH REMOTE SWITCHING

NOTE: This feature adds two attributes to the MICRO 200 analyzer:

- 1) The addition of an analog output either 4-20mA or 0-10V while operating in the backwash mode.
- 2) The ability to switch, at a remote location, between turbidity and backwash.

8.5.1 ELECTRICAL CONNECTIONS

8.5.1.1 Remote Switch

Connections are made at the analyzer terminal block J7 labeled MISC. INPUTS (SIGNAL). A dry (not powered) "A" contact connection between terminals 1 & 2 is required. With an open circuit between these contacts, the MICRO 200 will operate normally. Closing this circuit, while in the turbidity display, will cause the instrument to change to the backwash mode.

8.5.1.2 Alarms

Two sets of user settable alarm contacts are provided plus an additional sensor alarm. Separate Alarm set points may be made in either turbidity and backwash modes. Keep in mind that when you change modes these

contacts are still connected and active unless set to OFF in either of the modes.

8.5.1.3 Analog Outputs

Analog outputs of either 4-20 mA or voltage are available. If you select voltage you may choose 0-10V, 0-1V or 0-100mV. This analog output will be shared by both modes and will automatically recalibrate to the selected mode.

8.5.1.4 Serial Port (Optional)

If a serial port is connected the readings will report in NTU while in the turbidity mode and will report in %T while in the backwash mode.

8.5.2 OPERATION

With the remote switch set to the normal position (open), the instrument should be calibrated in both turbidity and backwash. All parameters such as alarm set points and display limits should be set as described in the O&M Manual. Press  key to return to the main menu. At any time, from this point on, you may set the remote switch to the backwash position (closed) and change over to the backwash display.

While in either mode any operating parameter may be changed by pressing  and entering the access code. Keep in mind that even while in the menus, all outputs are still active in which ever mode you were last in.

CAUTION: Keep in mind that when changing modes, the alarms, the analog output and the serial port (if connected) will also change modes.

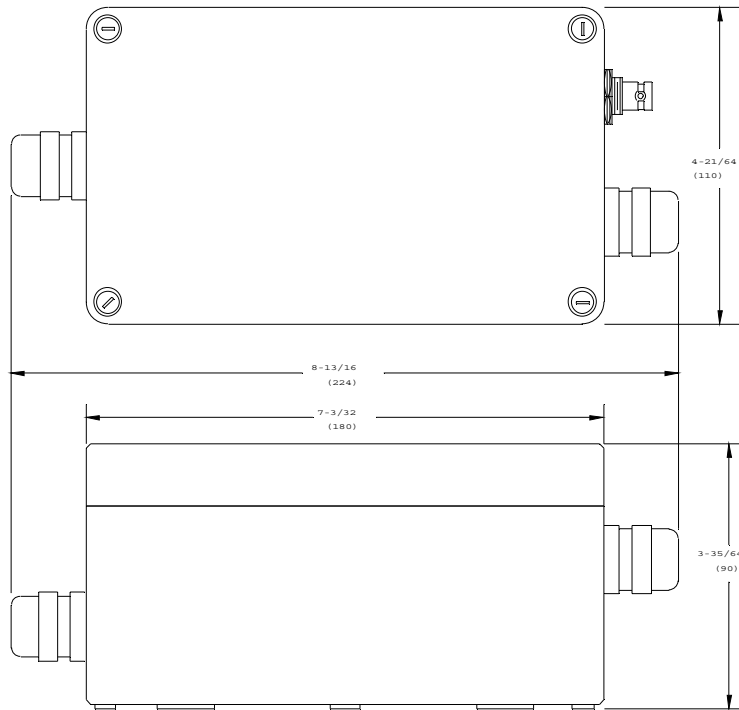

Figure 16
Backwash Interface Outline Dimensions

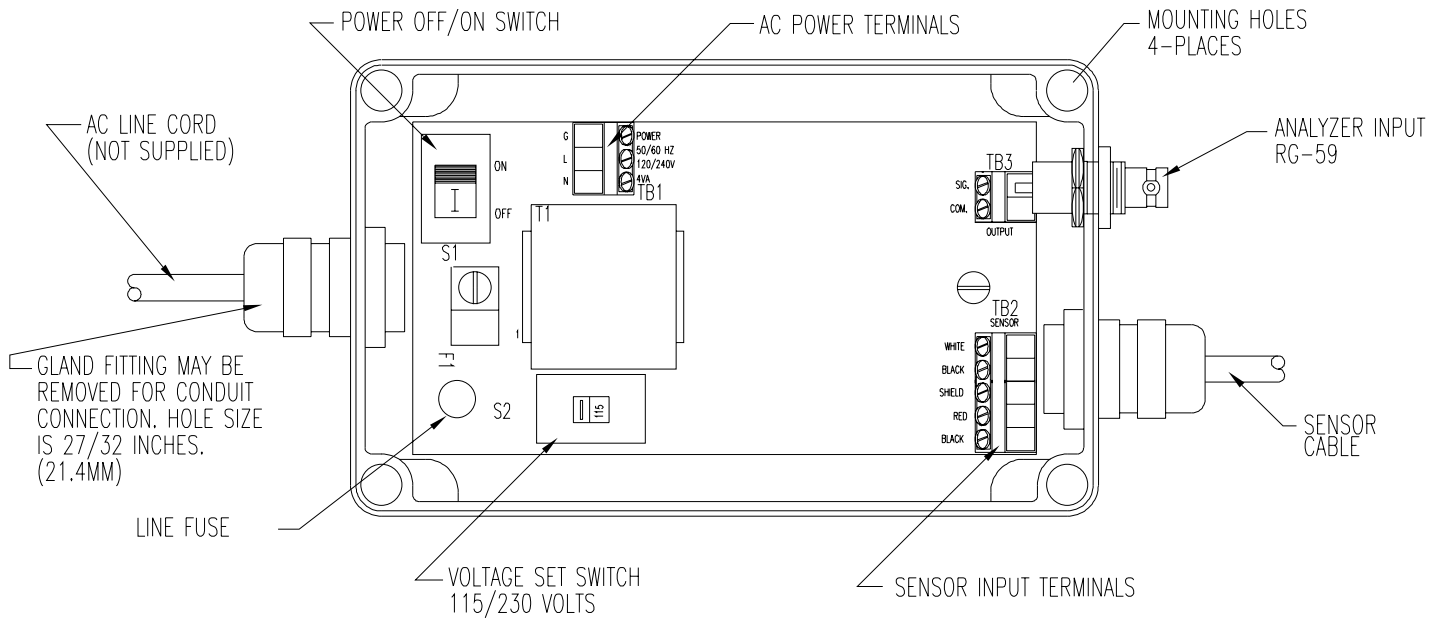

Figure 17
Backwash Interface Voltage Selection

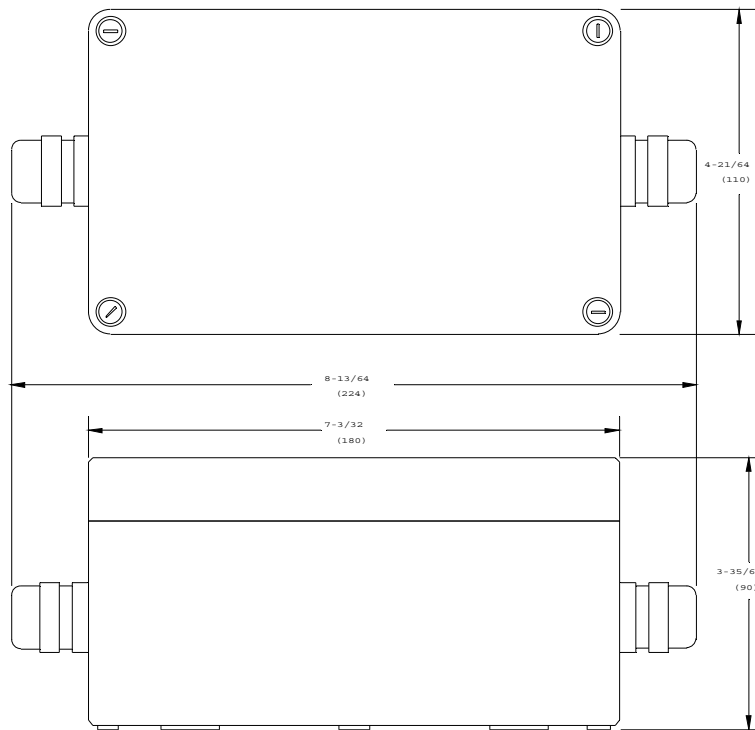
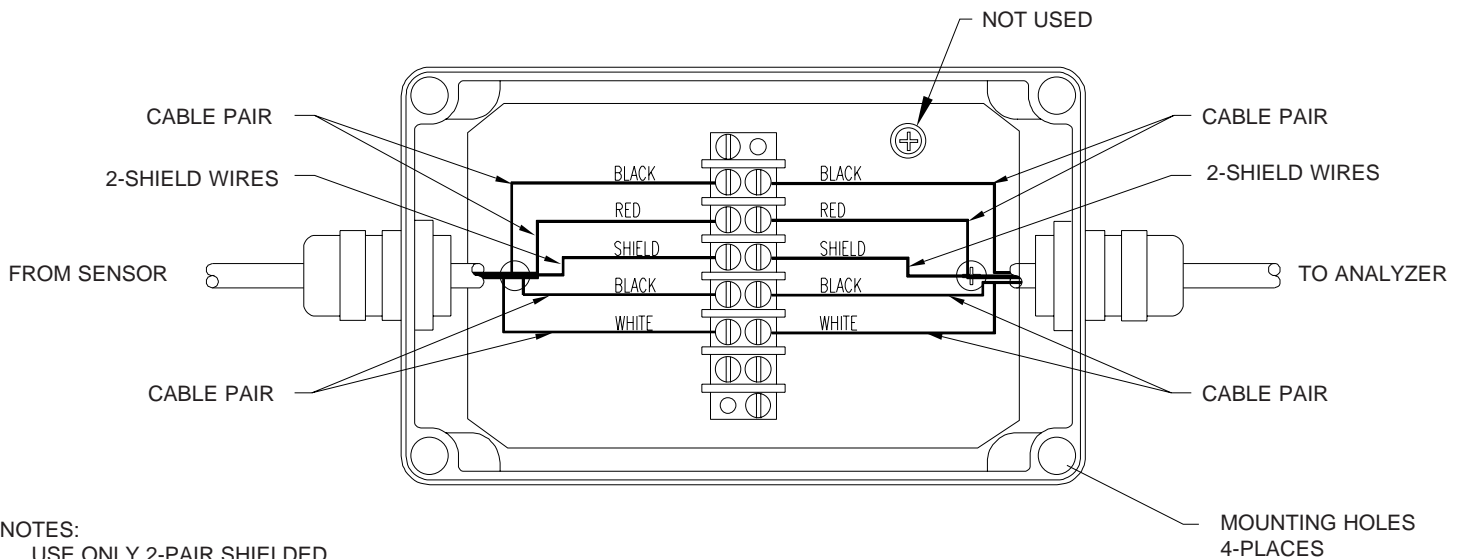

Figure 18
Junction Box Outline



NOTES:
USE ONLY 2-PAIR SHIELDED
CABLE TYPE 6052C.

Figure 19
Junction Box Wiring Diagram

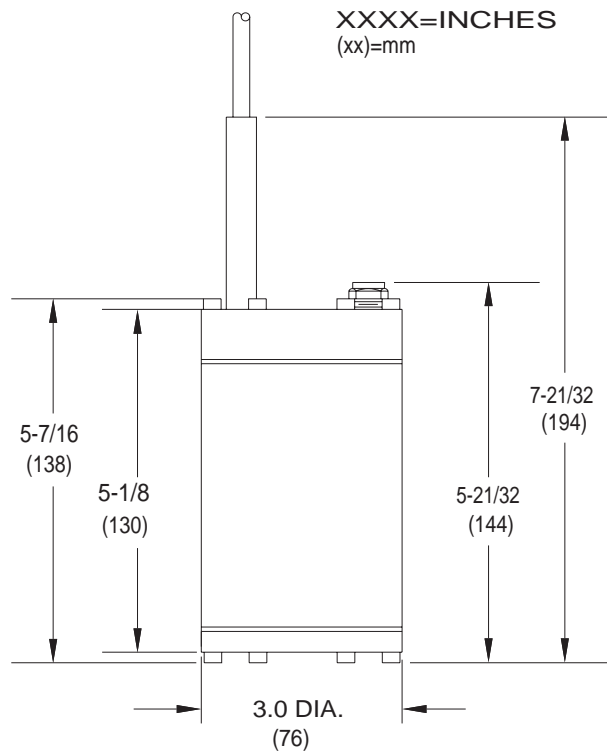

Figure 20
Backwash Sensor Outline Dimensions

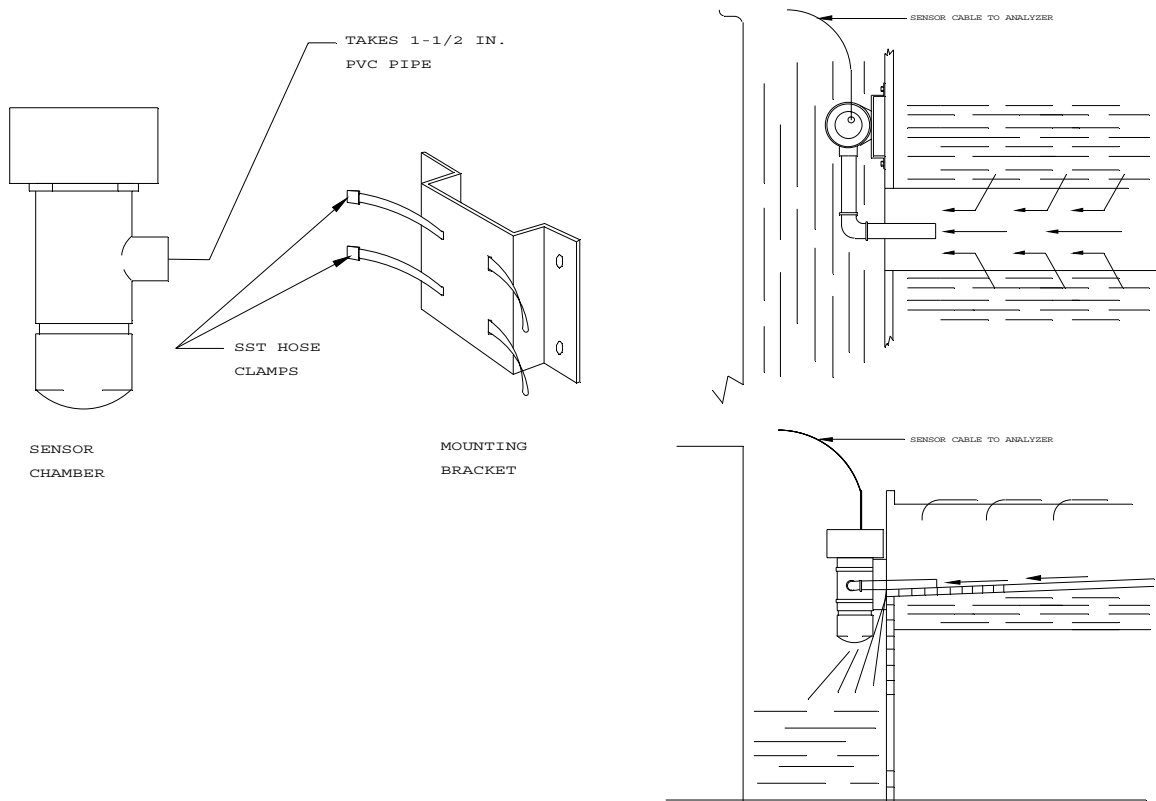
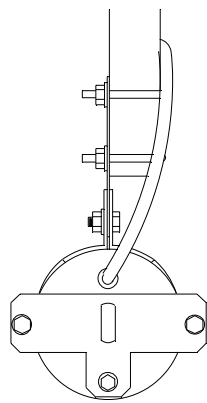
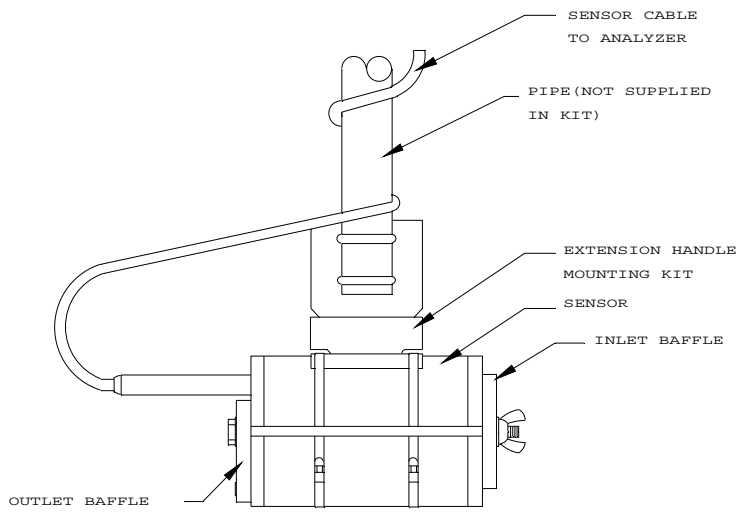
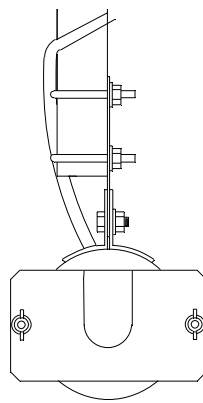

Figure 21
Backwash Channel Mounting



OUTLET BAFFLE



INLET BAFFLE

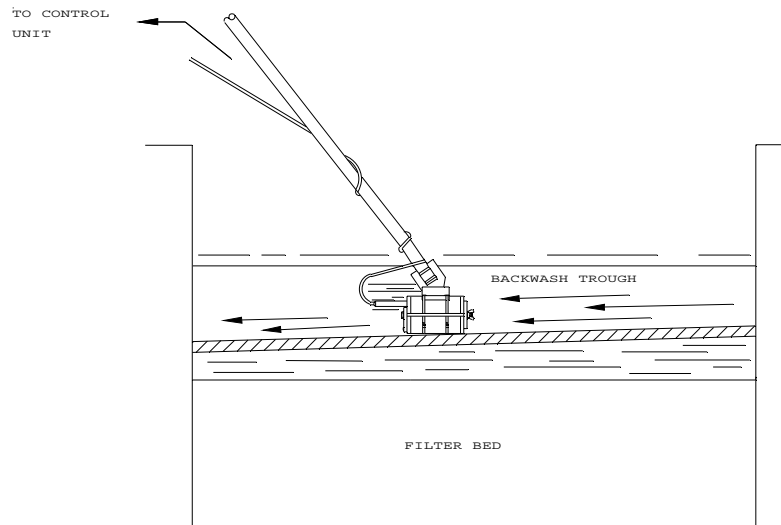

Figure 22
Backwash Extension Handle Mounting

8.0 OPTIONS - Continued

SERIAL INTERFACES

8.6 SERIAL INTERFACES

Each of these options may be installed by removing the rear cover of the analyzer as shown in figure 8 on page 10 and plugging in the interface as shown in figure 23.

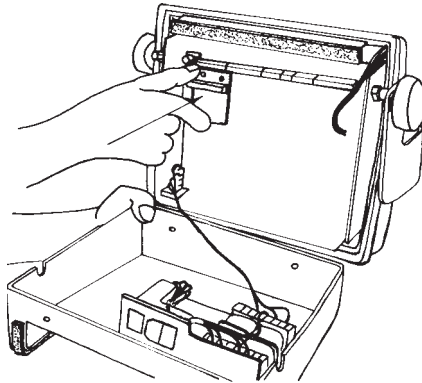

Figure 23
Serial Interface Installation

These options may be used to connect to a serial printer, a data logger or as a direct interface to a computer. The serial port will report each reading that is seen on the analyzer digital display. The protocol is 8 bits, no parity, 1 stop bit. The baud rate is screen selectable. The report is in ASCII format and is concluded with a carriage return and line feed.

As an example, if the display of the MICRO 200 BW reads 0.1234 NTU, the serial port decimal string would be:

Decimal	48	46	49	50	51	52	78	84	85	13	12
	0	.	1	2	3	4	N	T	U	(CR)	(LF)
ASCII											

(SP) = Space; (CR) = Carriage Return; (LF) = Line Feed

If the display reads 098.7 % T, the serial port decimal string would be:

Decimal	48	57	56	46	55	0	37	84	13	12
	0	9	8	.	7	(SP)	%	T	(CR)	(LF)
ASCII										

By selecting "Printer on" via the Main Menu, Utility Menu and the COMM Port menu, the MICRO 200 BW will transmit each reading, in real time. This mode is used to drive a printer for raw data collection.

By selecting "Printer Off" the MICRO 200 BW will only transmit its reading by command. Up to 16 MICRO 200 BW units may be simultaneously connected to one serial port of a host computer. An address may be assigned to a particular unit by operating F2 in the Comm Port Menu. It will serially cycle through addresses 0 through F (Hexadecimal). Obviously, no two units, which are on the same host computer port, should have the same address.

If the host computer transmits the ASCII character "@" (decimal 64) followed by the ASCII character address, for instance, 64, F, only the unit assigned address "F" will respond with its reading. This allows data logging for a non-dedicated host computer for up to 16 MICRO 200 BW units on only one of its serial ports. Both the MICRO 200 BW and the host computer must be set at the same baud rate. The host computer requires software to handle the data storage.

8.6.1 RS-232C Standard Voltage Mode Interface (Catalog # 19861)

This configuration is the standard serial port format (RS-232C). It is suitable where the cable length between the most remote MICRO 200 BW analyzer and the host computer does not exceed 50 feet (16.4 m.). Due to its "tri-state transmitter" design, the companion MICRO 200 BW units, which are on the same serial port at the host computer, may be "hubbed" or connected each one to the next as long as the total cable length from each MICRO 200 BW to the host computer does not exceed 50 feet (16.4 m.). See figure 24 on page 42.

TXD = Pin #1; Transmitted data out; Data to computer or printer

GRD = Pin #5; ground; digital common

RXD = Pin #8; received data in; data from computer to MICRO 200 BW

Please consult HF scientific, inc. for more detailed instructions.

8.6.2 RS-485 Half Duplex Interface (Catalog # 19851)

This option may be used where the distance from the host computer to the most remote MICRO 200 BW analyzer is, in extreme cases, up to 10,000 feet (3.28 km), depending on the site noise conditions. It is similar

to the RS-232 Standard Voltage Mode Interface except that it transmits in a “Balanced” mode, in one direction, at one time (half-duplex). This balanced mode makes it less susceptible to noise. It also maybe “hubbed” or connected each one to the next. It is important the most remote interface, and only it, should have it’s switch “closed” to properly terminate the network. Please consult HF scientific, inc. for more specific information. See figure 25 on page 42.

8.6.3 Serial Printer (Catalog # 19860)

This options provides a printout every 4 hours, or every 24 hours at midnight, of: date, time of period, minimum NTU, average NTU, and maximum NTU readings during the selected period. The printer option is supplied in a NEMA 4x enclosure intended for wall mounting. This option is shipped with an instruction manual addendum giving more detailed information on installation and operation. Please consult HF scientific, inc. for more specific information.

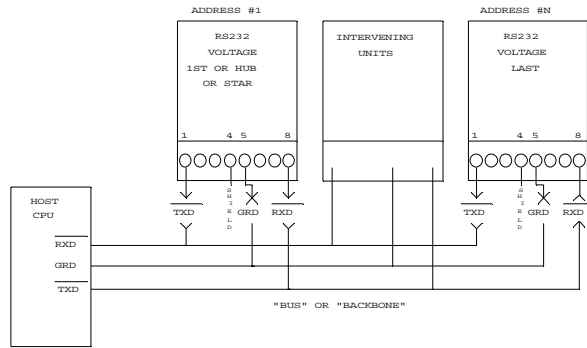

Figure 24
RS-232 Voltage Connection

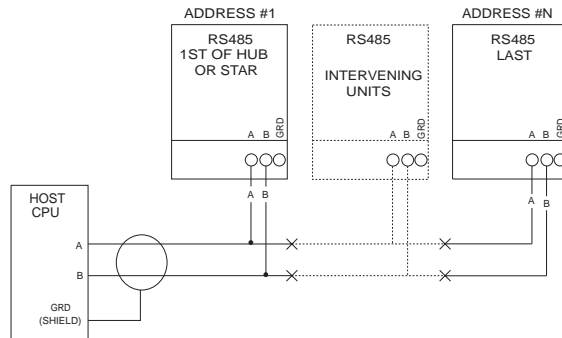

Figure 25
RS-485 Connection

WARRANTY

HF scientific, inc., as vendor, warrants to the original purchaser of the instruments to be free of defects in material and workmanship, in normal use and service, for a period of one year from date of delivery to the original purchaser. HF scientific, inc.'s, obligation under this warranty is limited to replacing, at its factory, the instrument or any part thereof. Parts which by their nature are normally required to be replaced periodically, consistent with normal maintenance, specifically lamps including fluorescent backlight, reagent, desiccant, sensors, electrodes and fuses are excluded. Also excluded are accessories and supply type items.

Original purchaser is responsible for return of the instruments, or parts thereof, to HF scientific, inc.'s factory. This includes all freight charges incurred in shipping to and from HF scientific, inc.'s factory.

HF scientific, inc. is not responsible for damage to the instrument, or parts thereof, resulting from misuse, negligence or accident, or defects resulting from repairs, alterations or installation made by any person or company not authorized by HF scientific, inc.

HF scientific, inc. assumes no liability for consequential damage of any kind, and the original purchaser, by placement of any order for the instrument, or parts thereof, shall be deemed liable for any and all damages incurred by the use or misuse of the instruments, or parts thereof, by the purchaser, its employees, or others, following receipt thereof.

Carefully inspect this product for shipping damage, if damaged, immediately notify the shipping company and arrange an on-site inspection. HF scientific, inc. cannot be responsible for damage in shipment and cannot assist with claims without an on-site inspection of the damage.

This warranty is given expressly and in lieu of all other warranties, expressed or implied. Purchaser agrees that there is no warranty on merchantability and that there are no other warranties, expressed or implied. No agent is authorized to assume for HF scientific, inc. any liability except as above set forth.

HF scientific, inc.
3170 Metro Parkway
Fort Myers, Florida 33916-7597
Phone: (239) 337-2116
Fax: (239) 332-7643

GLOSSARY

Alarms:	Relay outputs that change when an alarm setpoint has been exceeded.	LCD Display	Liquid Crystal Display (screen) used to view the information available on the MICRO 200 BW.
Backwash:	A method of measuring the transmission of filter backwash water.	Main Menu:	The major options for each of the functions accessed by the "FUNCTION" keys.
Baud:	Rate of transfer of serial information.	NTU:	Nephelometric Turbidity Units
Calibrate:	Electronic adjustment of the instrument to known standards.	Self Test:	A function that the MICRO 200 BW performs to check the internal analyzer voltages.
Cursor:	The LCD pointer indicating which digit or figure will change.	Set Alarm Point:	Setting the value at which an alarm will occur.
Cuvette:	Glass container used to hold the sample to be measured. It is placed in the optical well of the turbidimeter.	Set Average:	Selection of the time period used to average the display. Used to mitigate rapidly changing readings.
Comm Port:	Serial RS-232 or RS-485 communications port used for connecting a serial printer to generate hard copies of measurements or to data logging equipment.	Set Time:	Function used to Set the internal clock of the MICRO 200 BW
D to A:	Digital to analog conversion. Used to provide 4-20 mA and 0 - 10 V output signals.	Set Baud Rate:	Set the RS-232 information transfer rate.
Digit Up:	Command indicating an increment or increase of the digit selection.	Standardize:	Calibration of the lowest value of water.
Digit Down:	Command indicating a decrement or decrease of the digit selection.	Sub Menu:	Menu selections offered after selecting an option from the main menu.
Display Parameters:	The set up of information to be displayed on the LCD display.	Select:	A function that alternates among features or selections.
Display:	LCD display screen on the Analyzer.	Turbidity:	The measurement of light reflected by particles suspended in a fluid.
Frequency:	The number of cycles per second (hertz), of an alternating current signal.		
FTU:	Formazin Turbidity Units (see NTU)		
Host Computer:	A computer that is used to acquire and collect information from the serial port of one or more MICRO 200 BW analyzers (up to 16, Ø through F, Hexametadecimal).		
JTU:	Jackson Turbidity Units		

MATERIAL SAFETY DATA SHEET

HF scientific, inc.
3170 Metro Parkway
Fort Myers, FL 33916-7597
(239) 337-2116
Mon-Fri 8:00 am - 4:30 pm

24 Hour Emergency
Telephone Number
CHEMTREC
1-800-424-9300

SECTION 1 PRODUCT IDENTIFICATION

PRODUCT NAME: 100 %T STANDARD SOLUTION, 0.02 NTU PRIME TIME STANDARD, REFERENCE STANDARD, 0.02 NTU 250 ML PRIMARY STANDARD, and 0.02 NTU 1GALLON PRIMARY STANDARD, WATER - INCLUDING H2O PRIME TIME STANDARD.

CATALOG NUMBER:

HF scientific, inc.
14246/19199/19323/50047/60002/70908

U. S. Filter/Wallace & Tiernan:
AAC1556/AAC6608

CHEMICAL FAMILY: Not applicable

SYNONYMS: None

FORMULA: Turbidity free water (CAS # 7732-18-5), Preservative

SECTION 2 HAZARDOUS INGREDIENTS

No hazardous ingredients greater than or equal to 1%
No carcinogen greater than or equal to 0.1%

SECTION 3 PHYSICAL DATA

Boiling Point(F): Approximately 212 deg F (100 deg C)

Solubility in Water: Miscible

Vapor Pressure (mm Hg): Not determined

Appearance and Odor: Clear and colorless; no odor.

pH : 1.1 - 2.0 at 25 deg C

Vapor Density(AIR=1): Not determined

Specific Gravity (H₂O=1): Approximately 1

Melting Point: Approximately 32 deg C (0 deg C)

Evaporation Rate: Not determined

Percent Volatile by Volume: Not determined

SECTION 4 FIRE AND EXPLOSION HAZARD DATA

Flash Point: Not Flammable

Flammable Limits: Not determined

Fire Extinguishing Media: Suitable to cause of fire

Fire Fighting Procedures: Suitable to cause of fire

Unusual Fire And Explosive Hazards: None

SECTION 5 HEALTH EFFECTS AND FIRST AID

Route(s) of Entry: Inhalation? No Skin? Yes Ingestion? Yes

Effects of Overexposure: Irritation of the eyes, mucous membranes and skin could occur.

Carcinogenicity: NTP? IARC MONOGRAPHS? OSHA REGULATED?
Not a carcinogen.

Signs and Symptoms of Exposure: Burning or irritation of the exposed area.

Medical Conditions Generally Aggravated by Exposure: None found

Emergency First Aid Procedures:

Skin: Wash with plenty of water for 15 minutes. Call physician if irritation occurs.

Eyes: Flush eyes with plenty of water for 15 minutes. Call physician.

Ingestion: Give large quantities of water. Do not induce vomiting. Never give anything by mouth to an unconscious person. Call physician.

Inhalation: Remove to fresh air. If breathing has stopped, give artificial respiration. Call physician immediately.

SECTION 6 REACTIVITY DATA

Stability: Stable

Conditions to Avoid: Organic matter, chlorates, active metals

Incompatibilities (Materials to Avoid): Organic matter, chlorates, active metals

Hazardous Decomposition Products: Toxic SO_x fumes

Hazardous Polymerization: Will not occur

SECTION 7 SAFE HANDLING AND USE

Steps to be Taken in Case Material is Released or Spilled: Neutralize with soda ash. Absorb with paper.

Waste Disposal Method: DISPOSE OF IN ACCORDANCE WITH ALL APPLICABLE FEDERAL, STATE AND LOCAL ENVIRONMENTAL REGULATIONS.

Precautions to be Taken in Handling and Storage: Avoid contact with skin, eyes and clothing. Store tightly closed in a cool, dry place.

Other Precautions: Do not open vial to preserve low turbidity of standard.

SECTION 8 CONTROL MEASURES

Respiratory Protection: None required in normal use.

Ventilation: General mechanical ventilation satisfactory in normal use.

Skin Protection: Rubber gloves

Eye Protection: Safety goggles

Other Protective Measures: None

Work/Hygenic Practices: Wash well if contact occurs

NO GUARANTEE IS MADE AS TO THE ACCURACY OF ANY DATA OR STATEMENT CONTAINED HEREIN. WHILE THIS MATERIAL IS FURNISHED IN GOOD FAITH, NO WARRANTY EXPRESS OR IMPLIED, OR MERCHANTABILITY, FITNESS OR OTHERWISE IS MADE. THIS MATERIAL IS OFFERED ONLY FOR YOUR CONSIDERATION, INVESTIGATION AND VERIFICATION AND HF SCIENTIFIC INC., INCLUDING ITS DIVISIONS, AFFILIATES AND SUBSIDIARIES, SHALL NOT IN ANY EVENT BE LIABLE FOR SPECIAL, INCIDENTAL, OR CONSEQUENTIAL DAMAGES IN CONNECTION WITH ITS PUBLICATION. LIKEWISE, NO STATEMENT MADE HEREIN SHALL BE CONSTRUED AS A PERMISSION OR RECOMMENDATION FOR THE USE OF ANY PRODUCTION IN A MANNER THAT MIGHT INFRINGE EXISTING PATENT.