

**OPERATING & MAINTENANCE**  
**MANUAL**  
**OIL CONTENT BILGE ALARM**

HF scientific, inc.  
3170 Metro Parkway  
Ft. Myers, FL 33916-7597  
Phone: (239) 337-2116  
Fax: (239) 332-7643

# At Sea Spare Parts Kit for the HF scientific, inc. Bilge Alarm



At Sea Spare Parts Kit  
Cat. No. 81080

- i Clean, calibrate and repair your instrument in the field or at sea
- ii Avoid rush orders for spares while in port

The HF Bilge Alarm Spare Parts Kit contains the recommended spare parts needed for standard maintenance and repair. This kit contains detailed instructions designed to allow the ship's engineer to service the instrument without a costly port service call.

Save 40% over individually priced spare parts cost.

## Bilge Alarm Spare Parts Kit Contents:

Qty.	Description	Cat.No.
1	In line calibrator	20098
2	Fuse $\Omega$ A/120V	50016
2	Fuse $^{\circ}$ A/240V	50017
1	Light Detector Assembly	80995
2	Lamps for Recirc./Overboard	81007
1	Photodiode Assembly	81010
1	Side Panel Assembly	81025
1	Power Supply Board	81030
1	Amplifier Board	81033
1	Instruction Manual	81099
1	Cleaning brush for sensor	81095
1	Rugged plastic case	81094
1	Source Lamp	80996



3170 Metro Parkway  
Fort Myers, FL 33916-7597  
Phone: (239) 337-2116  
Fax: (239) 332-7643  
Rev 4/98

**IMPORTANT**

**Calibration / Cleaning Kit**

Note: This unit has been factory calibrated and should not require further adjustment.

Your Oil Content Bilge Alarm requires a calibration check every 3 - 4 months or anytime either mechanical or electrical adjustments have been made to the unit.

The calibration procedure is detailed in this instruction manual and requires HF Part # 20098.

**This kit should be ordered now so that material is available when calibration is required due to time constraints, equipment adjustment or compliance agency request.**

Please complete and mail to HF scientific, inc. 3170 Metro Parkway, Ft. Myers, Florida, U.S.A. 33916-7597.

---

**PURCHASE ORDER FORM**

Ship to:

Bill to:

---

---

---

---

---

---

---

---

P.O. Number (if required): \_\_\_\_\_

Name: \_\_\_\_\_

Phone: \_\_\_\_\_

<u>Qty.</u>	<u>Description</u>	<u>Cat. No.</u>	<u>Price (each)</u>
1	Oil Content Bilge Alarm Calibrator Kit & Cleaning Brush	20098	\$230.00

## CONTENTS

	PAGE
I. SPECIFICATIONS .....	1
II. WARNING NOTICE .....	2
III. OPERATION .....	2
IV. INSTALLATION .....	2
V. ALARM CONNECTIONS .....	2
VI. START-UP .....	3
VII. CALIBRATION .....	3
VIII. CALIBRATION CHECK .....	3
IX. ISOLATION VALVES .....	4
X. SETTING ALARM LEVEL .....	4
XI. INDICATING LAMPS .....	4
XII. CLEANING SENSING MODULE WINDOWS .....	4
XIII. REPLACING SOURCE LAMP .....	4
XIV. REPLACING SENSING MODULE MEASUREMENT DETECTOR .....	5
XV. REPLACING SENSING MODULE FAILSAFE LIGHT DETECTOR .....	5
XVI. TROUBLE SHOOTING GUIDE .....	6
XVII. TEST PROCEDURES FOR POWER SUPPLY BOARD .....	7
XVIII. SPARE PARTS .....	8
XIX. WARRANTY .....	10

## LIST OF FIGURES

1	SYSTEM INSTALLATION DIAGRAM .....	11
2	SENSOR INSTALLATION DIAGRAM .....	12
3	WIRING DIAGRAM .....	13
4	INTERCONNECT WIRING .....	14
5	LOCATION OF PARTS .....	15
6	LOCATION OF PARTS .....	16
7	SENSOR CONNECTIONS .....	17
8	CONTROL MODULE OUTLINE .....	18
9	SENSING MODULE OUTLINE .....	19
10	DISPLAY BOARD SCHEMATIC .....	20
11	POWER SUPPLY SCHEMATIC .....	21
12	AMPLIFIER BOARD SCHEMATIC .....	22

## I. SPECIFICATIONS

Range	0 - 100 PPM
Outputs	Recorder Output: 0-10 V.D.C., minimum impedance 500 ohms. Digital display: 2 1/2 digit. Display Readings & Alarm Set Point. Relay: Contacts rated at 5 amps. 120VAC, 28Vdc for Resistive Load. Activates upon: 1.High alarm. 2.Light Source Burn Out. 3.Fouled windows. Normal Operation: Fail safe; loss of power causes alarm.
Calibration check	Check switch
Operating Conditions	Power: 120/240 Volts $\pm$ 10%, 50/60 Hz Protection: Fused primary Temperature: 0-50 degrees C (122 degrees F.) (NOTE: When ambient temperatures drop below 0 degrees C. (32 degrees F.), (Sensing Module must be drained). Humidity: To 95% Vibration: - From 2Hz to 13.2 Hz $\pm$ 1mm amplitude. - From 13.2 Hz to 80 Hz with acceleration to .7G. Rolling Angle: 0-22.5 degrees
Critical Measurement	Response Time: Display - 5 seconds or less. Alarm - 16 seconds or less Measured Flow Rate: 40 g.p.m. maximum. Measured Pressure Range: 0-60 p.s.i.
Sensing Module	Weight: 6 lbs., 11 oz. (3.03 kg) Threads: 1" N.P.T. pipe (customer supplied). Dimensions: (Refer to Figure 9) Construction Materials: Body - Cast aluminum, neoprene O-Ring seals, Borosilicate pressure windows.
Interconnecting Cable	7 Conductor, shielded. Rated 80 degrees C., 300V. U.L. listed/CSA Certified. 15 ft. supplied.
Indicating/Control Module	Weight: 19 lbs. (8.62 kg) Dimensions: (Refer to Figure 8) Electronic components are mounted in an oil tight J.I.C. Enclosure with holes for 1/2" conduit.

Amplifier P.C. Board has a plug-in connector and is fastened to the chassis for rigidity. It includes trim pots and Alarm Set and Calibration switches (Refer to Item A, Figure 5).

Power Supply P.C. Board includes test points, a plug-in connector, and is also fastened to the chassis (Refer to Item C, Figure 5).

## II. WARNING

The Sensing Module and the Indicating/Control Module are shipped with the Interconnecting Cable connected for reasons of convenience; however, electrical installation including routing of the Interconnecting Cable, power connections, calibration and servicing should only be done by qualified electricians and in accordance with applicable codes and regulations.

Caution should be exercised when working on components inside the Indicating/Control Module while power is on. Coming in contact with live components may cause electrical shock or damage to equipment.

If there is a possibility of voltage spikes or power surges to the instrument's power supply module, an approved line suppressor is recommended.

## III. OPERATION

Cleaned water from oily-water filtering equipment is continuously monitored.

The Bilge Alarm measures and displays the concentration level of dispersed oil in the flowing stream of cleaned water. The instrument consists of a Sensing module and an Indicating/Control module. Oil content of the cleaned bilge is continuously shown on the Indicating/Control module's digital display. An adjustable alarm set-point function, used to set the allowable oil concentration level, is located inside the Indicating/Control module. When the Sensing Module determines that the oil level exceeds the setpoint value, for longer than 15 seconds, a relay operates the lights on the display panel of the Indicating/Control Module. Green for "OVERBOARD" changes to red for "RECIRCULATE". Simultaneously two sets of relay contacts activate independent alarm circuits. When the oil level in the effluent water is once more below the set-point value, the green lamp for "OVERBOARD" will glow and the red lamp for "RECIRCULATE" will shut off. The relay contacts will also deactivate. The above performance is contingent upon and consistent with the recommendations stated in the IMO Recommendations for Performance and Test Specifications for Oil Content Meters:

"Non foaming detergents should not be used in the bilges for cleaning purposes, as the emulsifying effects of some compounds seriously affect the operation of the equipment. Non soluble suspended solids can give false high readings. The oil water

separators must incorporate a suspended particle filter. "

Piping for the Sensing Module is arranged in the outlet line of the Oily-Water Filtering Equipment. Cleaned bilge water, up to 60 psi, flows through the module past optical windows where the measurement is made. A pre-focused incandescent light source provides a light beam which passes through the bilge water. A detector, placed at a 90° angle to the incident light beam, measures light scattered by the dispersed oil in the bilge water. An electrical output from the detector is transmitted through a cable to the Indicating/Control Module where it is processed. The measurement is displayed on the panel in "PPM".

The digital display on the front panel shows 2 1/2 digits and can indicate readings up to 100 PPM accurately. Readings over 100 PPM are not reliable. An "ON/OFF" switch, for providing power to the Bilge Alarm, is also located on the panel.

## IV. INSTALLATION

Install the Sensing Module using 1" piping after the Oily-Water Filtering Equipment.

To permit use of the Bilge Alarm Calibration Kit, as well as a laboratory cleaning brush to clean the windows by brushing through when required, connect piping as shown in Figure #2. Sensor must be mounted vertically as shown in Figure 2, page 12, to allow the use of calibration kit Part No. 20098.

Piping should be in accordance with 46 C.F.R. 56.01-IOD (U.S.Coast Guard).

Connect Sensing Module to Indicating Control Module, as per Figures #3, #4, #7. Seal the cable entrance to the Sensing Module against the penetration of water vapor.

Connect Power Source through fused switch to Terminals #6 and #7, in the Indicating/Control Module per Figures #3 and #4. Connect ground to Terminal #E9 per Figures #3 and #6. Selection of 115 volt or 230 volt operation can be made with the switch in the Indicating/Control Module as shown in Figure #6, Item A. Use two 1/2 Amp fuse only for 120V; use two 1/4 Amp fuse for 240V.

**NOTE:** Change both fuses for either mode of operation.

## V. ALARM CONNECTIONS

Contacts for the Alarm Relay are located in the Indicating/Control Module. These are "Dry" contacts with ratings

of 5 amps at 120VAC or 28 VDC resistive. There are two sets of contacts which may be used to operate valves, sound alarms, etc. These are wired as follows refer to Figure #3 and #4. Note that the relay is de-energized in the Alarm condition.

TB3	Set #1	Terminal #17 - Closed in the Alarm Condition Terminal #18 - Common Terminal #19 - Open in the Alarm Condition
TB3	Set #2	Terminal #20 - Closed in the Alarm Condition Terminal #21 - Common Terminal #22 - Open in the Alarm Condition

**VI. START-UP**

1. Turn on the Power Switch located on the Indicating/Control Module.
2. Allow the instrument to warm-up for approximately 30 minutes for stabilization. It is recommended that the power to the instrument be left on continuously except when servicing is required.
3. Run clean oil-free water through the Sensing Module.
4. Adjust the Zero Pot in the Indicating/Control Module (Item B, Figure #6) to cause Digital Display to indicate 00 PPM. NOTE: Negative readings on the Digital Display are indicated by a negative sign lighting up to the left of the Display Digits. When making adjustments do not over-adjust to negative values.

**VII. CALIBRATION**

The instrument has been factory calibrated in PPM. However, if it is desired to check calibration, the following procedure should be followed:

1. Run clean oil-free water through the Sensing Module and adjust "Zero" control.
2. Using an In-Line Calibration Holder, HF Part No. 20098, place a suitable calibration standard, equivalent to a known value of oil in water, in the Sensor.
3. When conditions have stabilized, observe Recorder Output reading; it should read 10 Volts DC for 100 PPM and any proportional linear value between zero and 10 volts for lower values (see example below). Recorder output is obtained

across terminals 10 (neg.) and 11 (pos.) in the Indicating/Control Module, (Refer to Figure #4).

**EXAMPLES:**

PPM (Oil in Water)	Recorder Output Reading
100 PPM	10 Volts
15 PPM	1.5 Volts

4. Calibrate the Recorder Output to correct value by adjusting the Trim Pot marked REC on the Amplifier P.C. Board, (Refer to Item D, Figure #5).
5. Adjust the Trim Pot marked DVM, on the same P.C. Board, to cause the Digital Display to read the correct value in PPM.

**NOTE:**

1. Whenever the value of the oil free water changes, it can be "Calibrated Out" by simply running a sample of the oil free water through the Sensing Module and adjusting the "ZERO" Pot in the Indicating/Control Module (Item B, Figure #6) to obtain a reading of "00" on the Digital Display.
2. Calibration should be checked after components have been replaced, i.e., P.C. Board, or Lamp, etc.
3. Whenever the instrument is re-calibrated a new "Cal Check" number should be obtained and recorded. See "Calibration Check" and follow steps 1 through 4.

**VIII. CALIBRATION CHECK**

This is a procedure used to check that the electronic function is still within the limits set by the Calibration Check Number.

1. Open the Indicating/Control Module.
2. Activate the CAL Check Switch (Item F, Figure 5, Spring Return) and note reading.
3. With the Cal Check Switch returned to its normal position and note reading.
4. Subtract the reading obtained in Step #3 above from that obtained in Step #2.
5. Compare the value obtained, which is the current Cal Check value, to the Cal Check number supplied with the instrument, which is affixed to the Indicating/Control Module Chassis. Should this current value vary by more than three (3) units from the original value, then the instrument should be re-calibrated.

## **IX. ISOLATION VALVES**

Isolation valves should be operated to shut-off flow from the Oily-Water Filter under each of the following conditions:

- Conducting service on the Sensing Module.
- Calibration
- Replacement of Sensing Module

Otherwise always ensure that the valves are positioned to provide flow to the Sensing Module.

## **X. SETTING ALARM LEVEL**

Activate "Alarm Set" switch on the Amplifier P.C. Board in the Indicating/Control Module (Item E, Figure 5).

While holding the "Alarm Set" switch "On" (spring return) the Digital Display will read the Alarm Set Value.

Adjust the "Alarm" Trim Pot (Item G, Figure 5) while holding the Switch "On", to cause the Digital Display to read desired Alarm Level. Release the "Alarm Set" Switch.

The Alarm Relay will activate 15 seconds after the PPM Oil-in-Water content has constantly exceeded the Alarm Set value.

## **XI. INDICATING LAMPS**

Green light is ON, Red light is OFF, whenever Unit is operating under Normal Conditions.

Red Light is ON and Green Light is OFF, during Alarm Conditions.

The reading must remain over the alarm set value for 15 seconds to activate the alarm relay.

## **XII. CLEANING THE SENSING MODULE WINDOWS**

The Sensing Module through which the fluid flows and in which a light beam is projected to measure oil content in the effluent contains three precision glass windows.

One indication that these windows may require cleaning is when the system enters the recirculation mode and remains in this mode even though a sample of the effluent from the Oily-Water Filter appears clean.

Cleaning may also be required when oil-free water requires considerable adjustment on the Zero Pot (Item B, Figure

6) even though the water appears clean, or when the display shows a PPM count less than the true value.

A periodic cleaning routine should be established to preclude the system from remaining in the recirculation mode because of a fouled flow channel. The frequency of the cleaning operation should be determined on the basis of the type of fluids being processed and how often the flow channel becomes contaminated during initial system use. Procedure for cleaning is as follows:

1. Turn off the flow to the Sensing Module.
2. Remove the clean-out plugs shown in Figure 2.
3. Use a mild detergent on a laboratory cleaning brush and pass the brush through the Sensing Module flow channel several times. Then rinse with clean water.
4. Replace the clean-out plugs.
5. Resume normal flow.

## **XIII. REPLACING SOURCE LAMP ASSEMBLY**

The Source Lamp in the Sensing Module may burn out occasionally and require replacement. This failure will cause the Bilge Alarm to go into an Alarm Condition (Refer to Figure 7).

1. Turn OFF the Power Switch at the Indicating/Control Module.
2. Remove the four screws in Sensing Module End Cap and remove the Sensing Module End Cap.
3. Unscrew all lug connections except at positions #1 and #2. Save all the screws as they will be needed later.
4. Cut the shield wire for Failsafe Light Detector at position #2.
5. Remove screws #8 & #9 and remove the Source Lamp Assembly.
6. Replace source lamp assembly with new unit. Check that orientation is correct, then reinstall screws #8 & #9.
7. Replace all lug connections at the correct positions.
8. Solder shield wire for Failsafe Light Detector to solder lug at position #2.
9. Replace Sensing Module End Cap and fasten four screws.
10. Turn Power Switch ON at Indicating/Control Module.
11. This completes the Source Lamp Assembly replacement. Proceed to Section VII (Calibration) and perform calibration as described.

#### **XIV. REPLACING SENSING MODULE**

##### **MEASUREMENT DETECTOR** (Refer to Figure 7)

1. Turn OFF the Power Switch at the Indicating/Control Module
2. Remove the four screws in Sensing Module End Cap and remove the Sensing Module End Cap.
3. Cut wires at positions #5, #6, and #7.
4. Remove the brass Measurement Detector Cap, located on the side of the sensor.
5. Remove the Measurement Detector Spacer.
6. Remove the Measurement Detector Assembly including wires cut in step #3 above.
7. Install the replacement Measurement Detector Assembly by feeding the wire of the assembly through hole.
8. Carefully seat Measurement Detector in position.
9. Replace Light Detector Spacer and brass cap.
10. Solder three wires attached to Measurement Detector to lugs on position #5, #6 & 7 (black wire to #5, shield wire to #6 and red wire to #7).
11. Replace Sensing Module End Cap.
12. Turn ON the Power Switch at the Indicating/Control Module and ensure that the Bilge Alarm is responding correctly to changes in oil concentration.
13. This completes the Measurement Detector replacement. Proceed to Section VII (Calibration) and perform calibration as described.
8. Place replacement Light Detector Assembly and Spacer in position and replace the Light Detector Cap with the four screws previously removed.
9. Solder three wires attached to Light Detector Assembly to lugs on positions #2, #3, and #4, (shield wire to #2, black wire to #3, and red wire to #4).
10. Replace the Sensing Module End Cap and Light Detector Cap.
11. Turn ON the Power Switch at the Indicating/Control Module and ensure that the Bilge Alarm is in the normal condition with clean water in the Sensing Module. Insert opaque object in Sensing Module Flow channel to block light to Light Detector to ensure that the Bilge Alarm goes into the Alarm Condition.
12. This completes the Failsafe Light Detector replacement procedure.

#### **XV. REPLACING SENSING MODULE FAILSAFE LIGHT DETECTOR** (refer to Figure 7)

**NOTE:** The Light Detector is a failsafe feature which draws attention to lamp burn-out or opaque obstruction conditions and will not normally need replacement during the life of the instrument).

1. Turn OFF the Power Switch at the Indicating/Control Module.
2. Remove the four screws in Sensing Module End Cap and remove the Sensing Module End Cap.
3. Cut the black and red wires at positions #3 and #4 and shield wire at position #2.
4. Remove the four screws in Light Detector Cap located on opposite end of the Sensing Module and remove Cap.
5. Remove Light Detector Spacer.
6. Remove Light Detector Assembly including wires cut in #3 above.
7. Feed the three wires on the replacement Light Detector Assembly through to positions #2, #3, and #4.

## XVI. TROUBLE-SHOOTING GUIDE

SYMPTOMS	PROBABLE CAUSE	CORRECTIVE ACTION
Digital Display and/or indicating lights do not light up.	<ol style="list-style-type: none"> <li>1. No power to Indicating/Control Module.</li> <li>2. Blown fuses.</li> <li>3. Defective power supply board.</li> <li>4. Indicating lamp loose or burned out.</li> </ol>	<ol style="list-style-type: none"> <li>1. Turn on power switch. Check facility input power source.</li> <li>2. Replace fuses.</li> <li>3. Test power supply board as outlined under Test Procedures and replace if defective.</li> <li>4. Insert lamps properly or replace.</li> </ol>
Unit stays in recirculation mode when reading is below alarm set point.	<ol style="list-style-type: none"> <li>1. Sensing Module Source Lamp burned out.</li> <li>2. Defective Failsafe Light Detector.</li> <li>3. Alarm Relay Defective.</li> <li>4. Defective Power Supply Board.</li> <li>5. Opaque Obstruction in flow channel.</li> </ol>	<ol style="list-style-type: none"> <li>1. Replace Source Lamp. Re-check calibration.</li> <li>2. Replace Failsafe Light Detector.</li> <li>3. Replace relay.</li> <li>4. Test Power supply board as outlined under Test Procedures and replace if defective.</li> <li>5. Clean sensing module windows with detergent and a brush.</li> </ol>
Digital display does not change with changing concentration of oil.	<ol style="list-style-type: none"> <li>1. Defective Amplifier Board.</li> <li>2. Defective Digital Display.</li> <li>3. Open leads from sensor.</li> <li>4. Defective Measurement Detector Sensing Module.</li> </ol>	<ol style="list-style-type: none"> <li>1. Replace amplifier board (Item A, Figure 4) and re-calibrate.</li> <li>2. Replace complete Front Panel Assembly containing Digital Display Indicating Lights, etc.</li> <li>3. Inspect Leads and connecting wiring for breaks.</li> <li>4. Replace measurement detector.</li> </ol>
Digital display shows negative but Alarm and Recirculate light is on.	<ol style="list-style-type: none"> <li>1. Sensing Module Source Lamp Defective.</li> <li>2. Defective Amplifier PC Board.</li> <li>3. Defective Digital Display.</li> <li>4. Fouled windows in flow channel.</li> </ol>	<ol style="list-style-type: none"> <li>1. Replace Source Lamp in Sensing Module.</li> <li>2. Replace amplifier PC board (Item A, Figure 5) and recalibrate.</li> <li>3. Replace complete Front Panel Assembly.</li> <li>4. Clean Sensing Module Windows with detergent and a brush.</li> </ol>

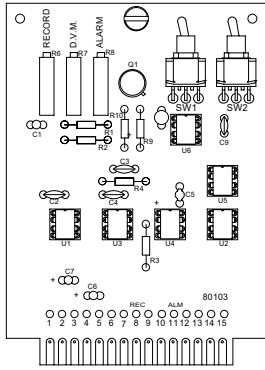
**XVI. TROUBLE-SHOOTING GUIDE (cont.)**

SYMPTOMS	PROBABLE CAUSE	CORRECTIVE ACTION
Readout shows negative.	<ol style="list-style-type: none"> <li>1. Cleaner oil free water.</li> <li>2. Defective amplifier PC board.</li> <li>3. Defective Digital Display.</li> </ol>	<ol style="list-style-type: none"> <li>1. Adjust zero. See “Start-up.”</li> <li>2. Replace amplifier PC Board (Item A, Figure 5) and re-calibrate.</li> <li>3. Replace complete Front Panel Assembly.</li> </ol>
When oil concentration as indicated by the digital Display, goes above Alarm Set Point, Controls stays in “Overboard” condition and does not change to “Recirculate.”	<ol style="list-style-type: none"> <li>1. Defective Alarm Relay.</li> <li>2. Defective Amplifier Board.</li> <li>3. Defective Failsafe Light Detector.</li> </ol>	<ol style="list-style-type: none"> <li>1. Replace Relay.</li> <li>2. Replace Amplifier PC Board (Item A, Figure 5) and re-calibrate.</li> <li>3. Replace complete Front Panel Assembly.</li> </ol>
“Cal Check” reading too high (see “Calibration Check”).	<ol style="list-style-type: none"> <li>1. Dirty Sensing Module Source Lamp.</li> <li>2. Defective Sensing Module Source Lamp.</li> <li>3. Defective Measurement Detector in Sensing Module.</li> </ol>	<ol style="list-style-type: none"> <li>1. Clean Sensing Module windows.</li> <li>2. Check Sensing Module Source Lamp and replace if necessary.</li> <li>3. Replace Measurement Detector.</li> </ol>

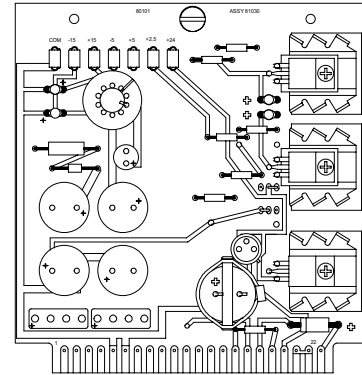
**XVII. TEST PROCEDURES FOR POWER SUPPLY BOARD (LOWER PC BOARD IN Figure 3)**

1. Turn Power OFF.
2. Remove Amplifier P.C. Board (Item A, Figure 5).
3. Unplug the Front Panel Harness Plug from the Socket, Item B, Figure 5.
4. Unplug the voltage plug from the socket, Item C, Figure 6.
5. Plug into socket (Item H, Figure 5) the Dummy Test Plug (Part #80276, supplied with instrument).
6. Turn Power ON.
7. Using a D.C. Volt Meter measure the voltages at the test points, i.e. between common (com) and each test point on Power Supply Board. They should be within  $\pm 10\%$  of value indicated and they should be stable.
8. If the voltages are not as indicated on every test point then replace Power Supply Board.
9. After testing and replacing Power Supply Board, if required, then turn Power OFF.
10. Remove Dummy Test Plug and reinstall Amplifier P.C. Board and replace Front Panel Harness Plug in socket Item C, Figure 6.
11. Reinstall the voltage plug into the voltage socket.
12. Turn Power ON.

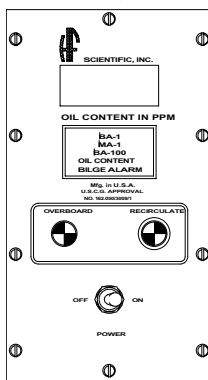
**XVIII. SPARE PARTS**



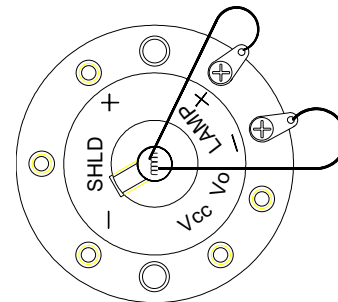
Amplifier P.C. Board Assembly  
 Catalog No. 81033  
 Qty. 1



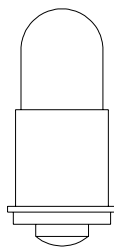
Power Supply P.C. Board Assembly  
 Catalog No. 81030  
 Qty1



Control Panel Complete w/Digital Display Lamps and  
 Switch  
 Catalog No. 81025  
 Qty. 1



Source Lamp Assembly  
 Catalog No. 80996  
 Qty. 1



Bulbs for Recirculate and Overboard Lamps  
 Catalog No. 81007  
 Qty. 2

Fuses, 1/2 Amp. SLO-BLO (110V) Catalog No. 50016

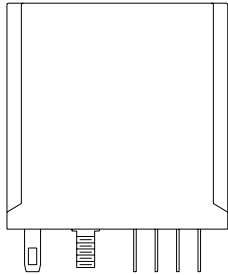
Qty. 2

Fuses, 1/4 Amp. SLO-BLO (220V) Catalog No. 50017

Qty. 2

(Pictures not available)

**XVIII. SPARE PARTS (Cont'd)**



Relay  
Catalog No. 80134  
Qty. 1

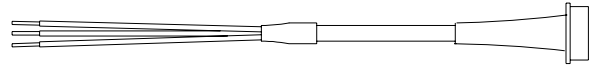
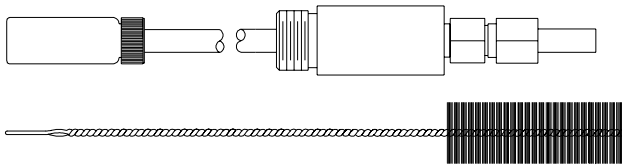
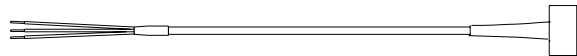


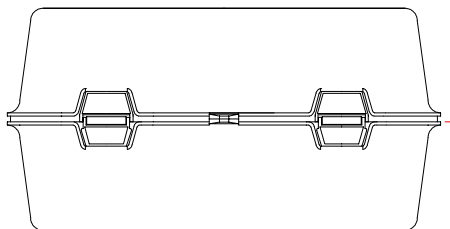
Photo Diode Assembly  
Catalog No. 81010  
Qty. 1



In-Line Calibrator Kit & Cleaning Brush  
Catalog No. 20098  
(Optional)  
Qty. 1



Failsafe Light Detector  
Catalog No. 80995  
Qty. 1



Bilge Alarm Spare Parts Kit  
(See literature at front of manual)  
Catalog No. 81080  
(Optional)  
Qty. 1

**ORDER FROM:**

HF scientific, inc.  
3170 Metro Parkway  
Fort Myers, Florida 33916-7597  
Phone: (239) 337-2116  
Fax: (239) 332-7643

## **XIX. WARRANTY**

HF scientific, inc., as vendor, warrants to the original purchaser of the instruments to be free of defects in material and workmanship, in normal use and service, for a period of one year from date of delivery to the original purchaser. HF scientific, inc.'s, obligation under this warranty is limited to replacing, at its factory, the instrument or any part thereof. Parts which by their nature are normally required to be replaced periodically, consistent with normal maintenance, specifically lamps including fluorescent backlight, reagent, sensors, desiccant, electrodes, and fuses are excluded. Also excluded are accessories and supply type items.

Original purchaser is responsible for return of the instruments, or parts thereof, to HF scientific, inc.'s factory. This includes all freight charges incurred in shipping to and from HF scientific, inc.'s factory.

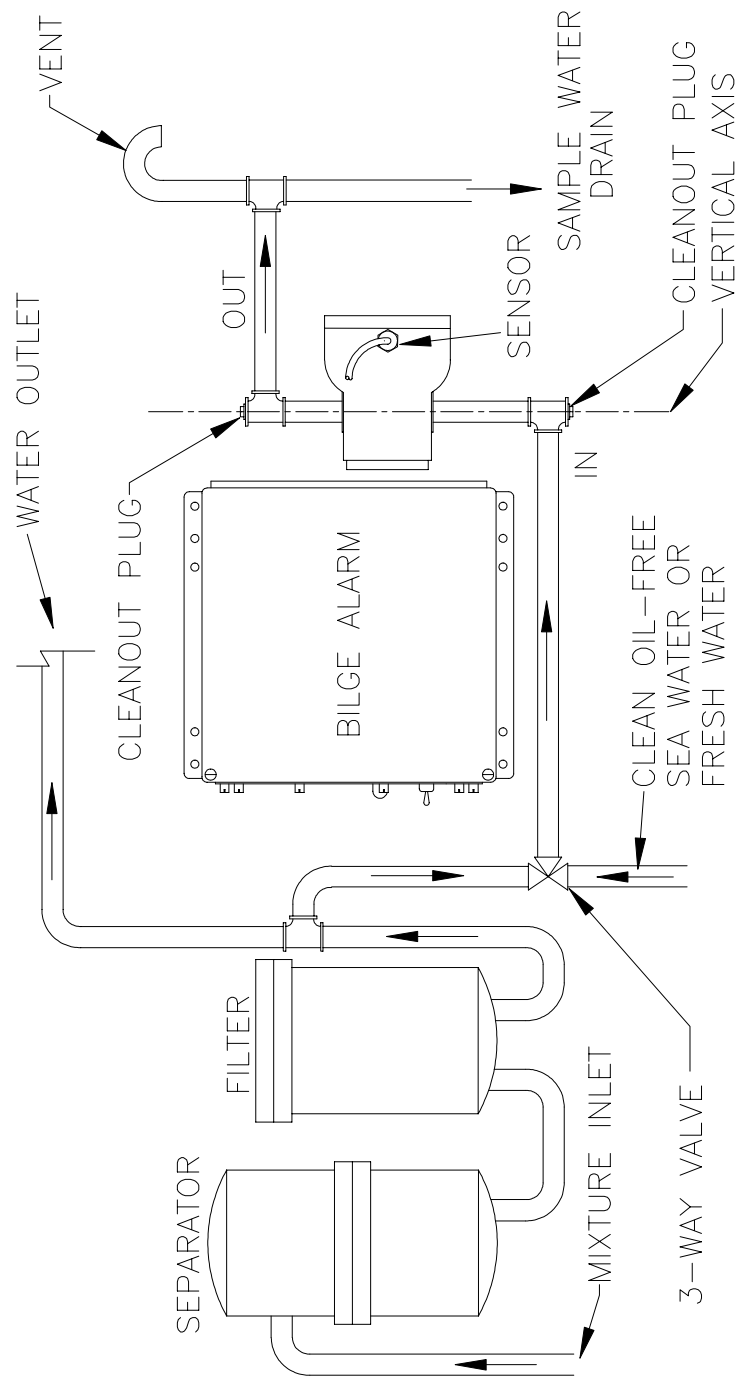
HF scientific, inc. is not responsible for damage to the instrument, or parts thereof, resulting from misuse, negligence or accident, or defects resulting from repairs, alterations or installation made by any person or company not authorized by HF scientific, inc.

HF scientific, inc. assumes no liability for consequential damage of any kind, and the original purchaser, by placement of any order for the instrument, or parts thereof, shall be deemed liable for any and all damages incurred by the use or misuse of the instruments, or parts thereof, by the purchaser, its employees, or others, following receipt thereof.

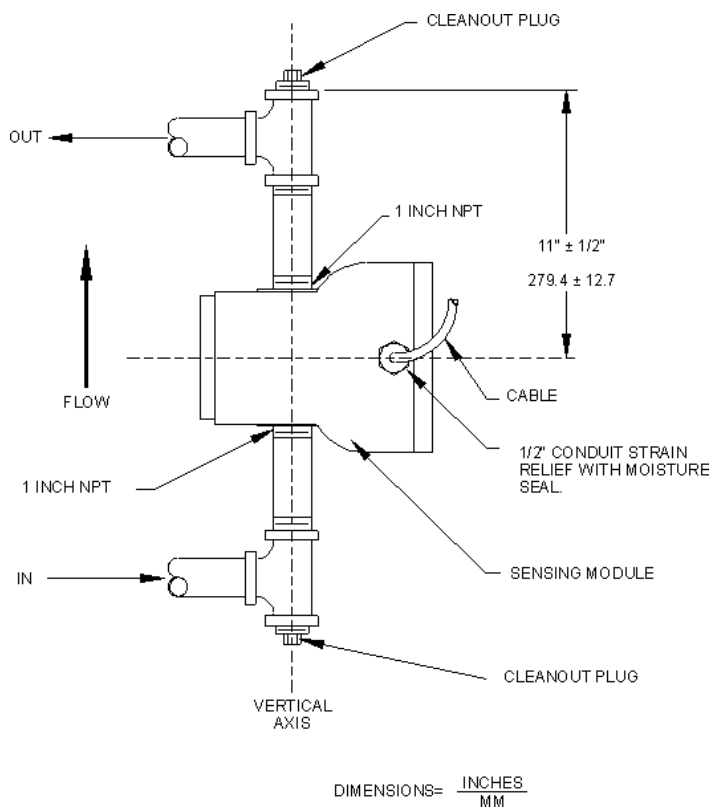
Carefully inspect this product for shipping damage, if damaged, immediately notify the shipping company and arrange an on-site inspection. HF scientific, inc. cannot be responsible for damage in shipment and cannot assist with claims without an on-site inspection of the damage.

This warranty is given expressly and in lieu of all other warranties, expressed or implied. Purchaser agrees that there is no warranty on merchantability and that there are no other warranties, expressed or implied. No agent is authorized to assume for HF scientific, inc. any liability except as above set forth.

HF scientific, inc.  
3170 Metro Parkway  
Fort Myers, Florida 33916-7597  
Phone: (239) 337-2116  
Fax: (239) 332-7643

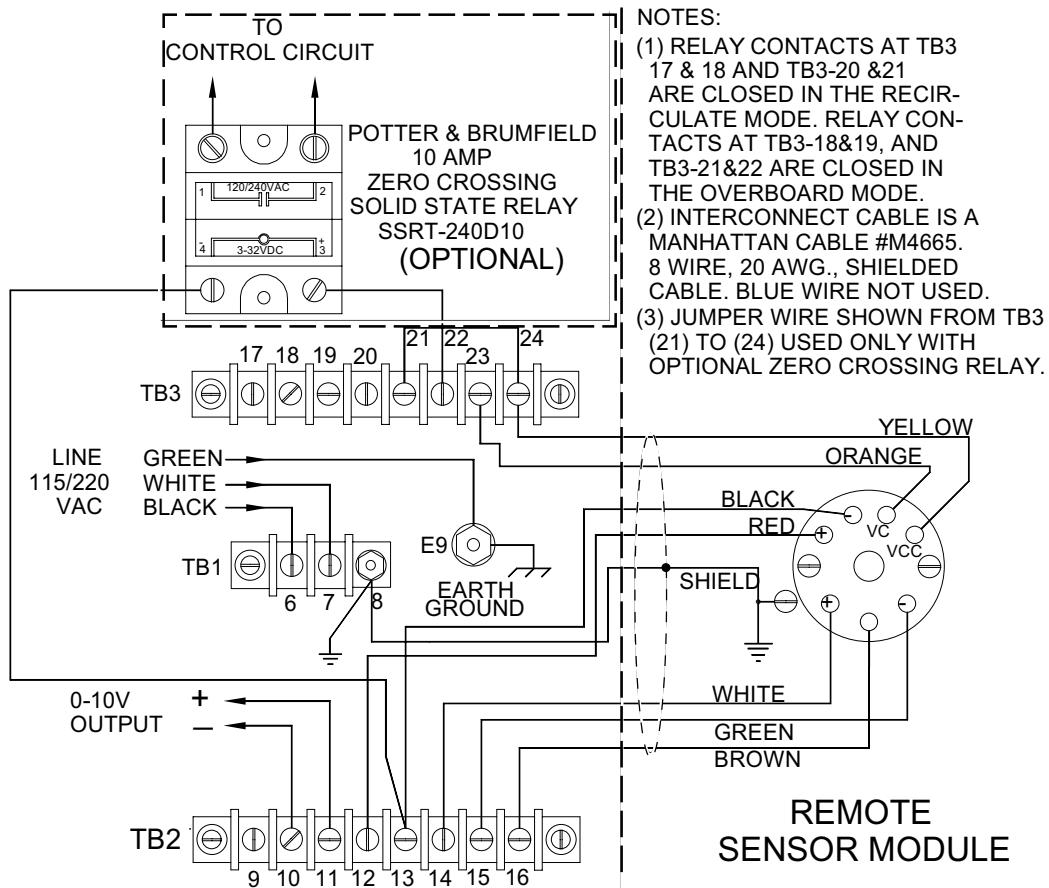


**System Installation Diagram**  
**Figure 1**



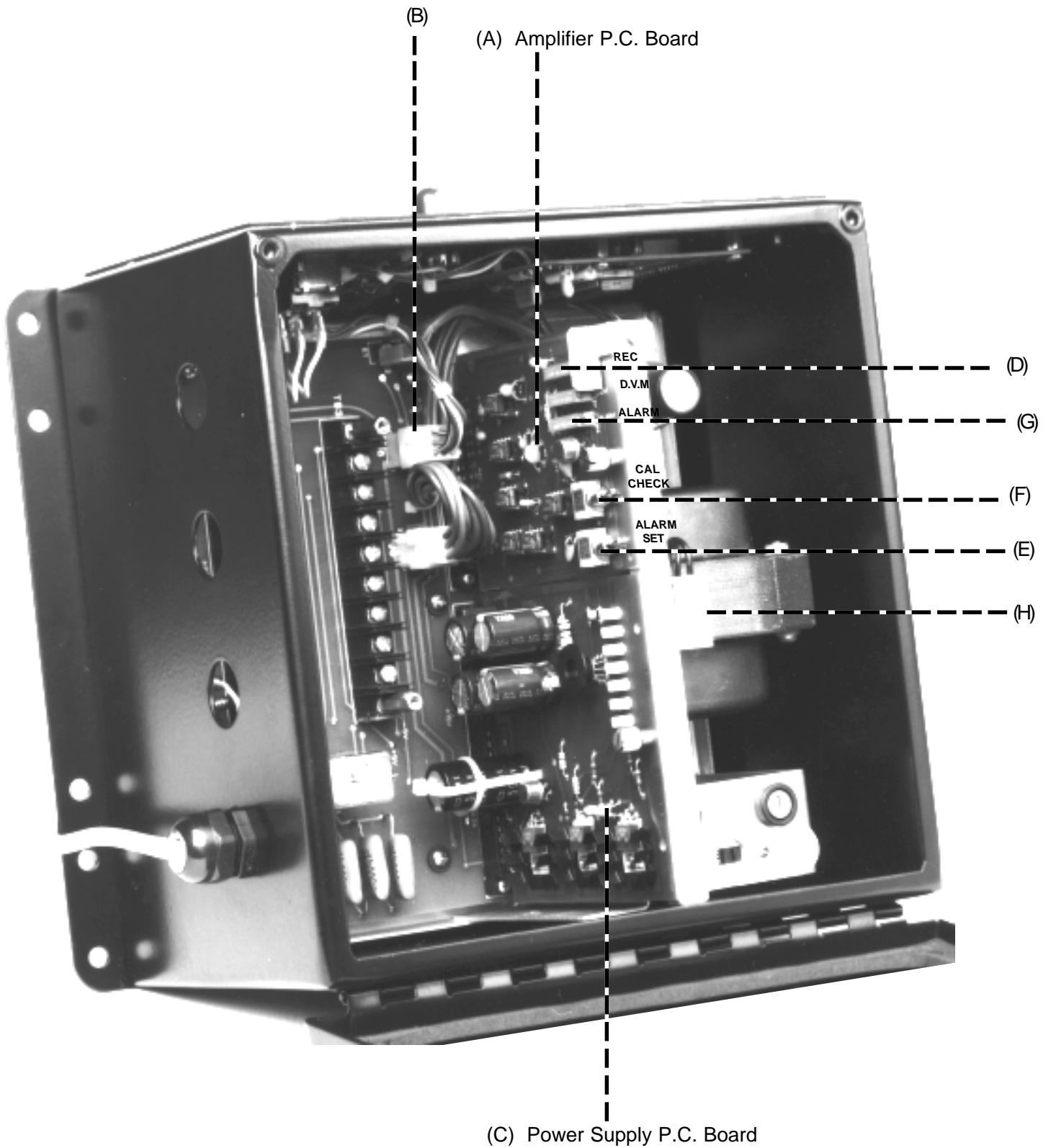
**Sensor Installation Diagram**  
**Figure 2**





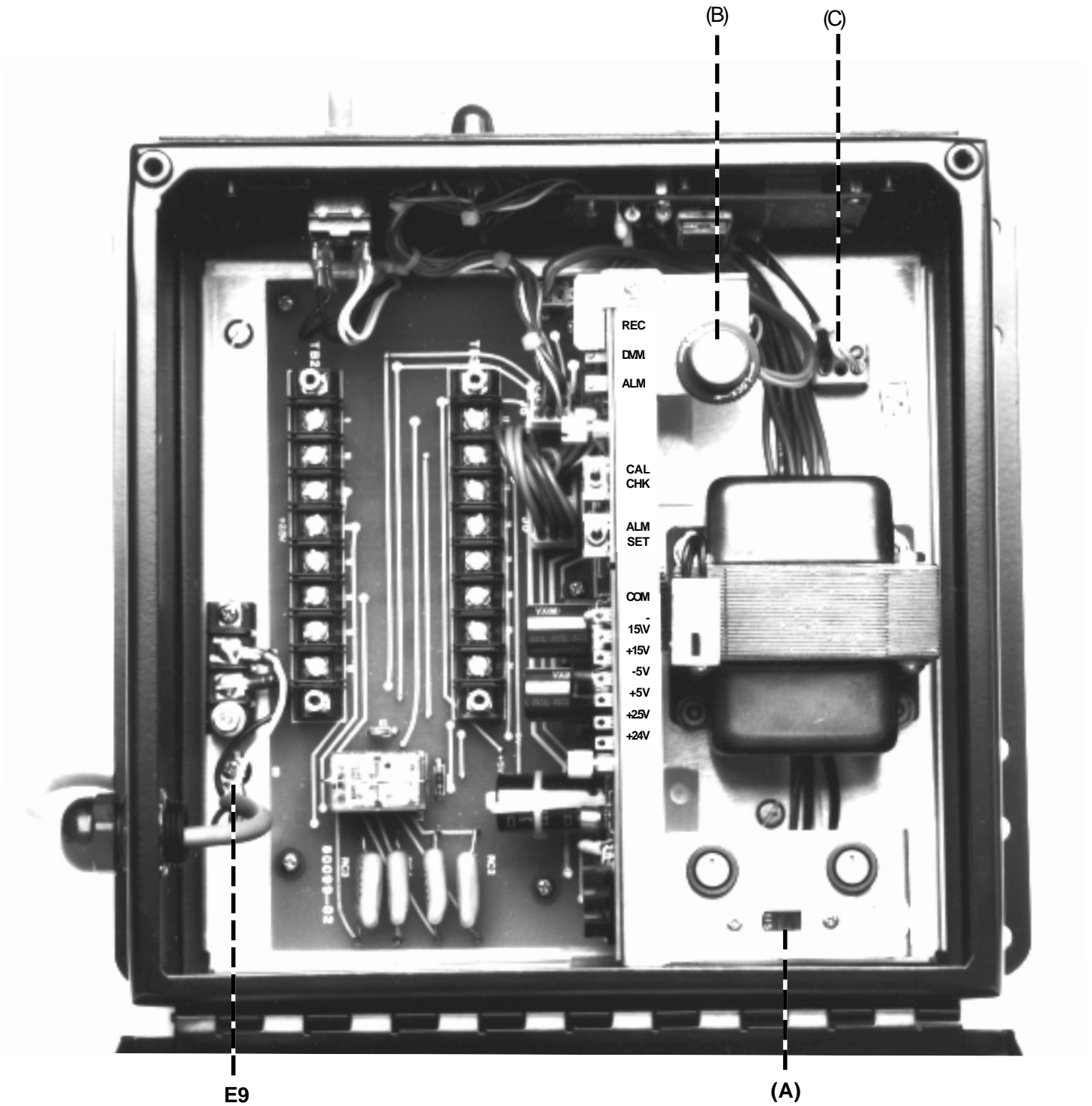
- NOTES:
- (1) RELAY CONTACTS AT TB3 17 & 18 AND TB3-20 & 21 ARE CLOSED IN THE RECIRCULATE MODE. RELAY CONTACTS AT TB3-18&19, AND TB3-21&22 ARE CLOSED IN THE OVERBOARD MODE.
  - (2) INTERCONNECT CABLE IS A MANHATTAN CABLE #M4665. 8 WIRE, 20 AWG., SHIELDED CABLE. BLUE WIRE NOT USED.
  - (3) JUMPER WIRE SHOWN FROM TB3 (21) TO (24) USED ONLY WITH OPTIONAL ZERO CROSSING RELAY.

**Figure 4**  
**Interconnecting Wiring**



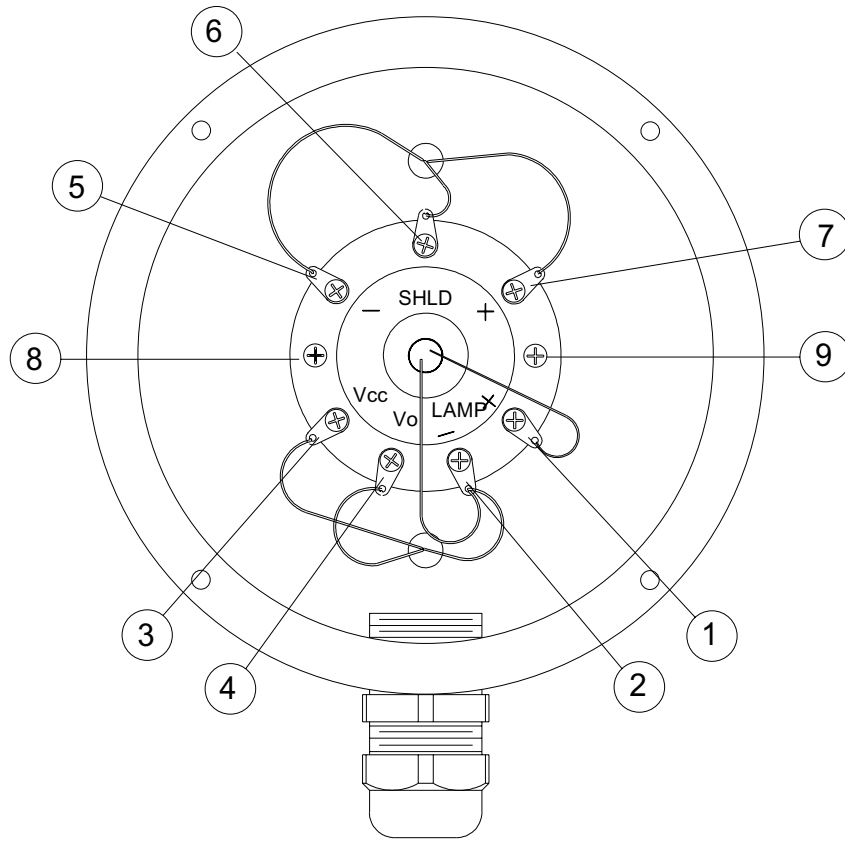
**Figure 5**  
**Location of Parts**



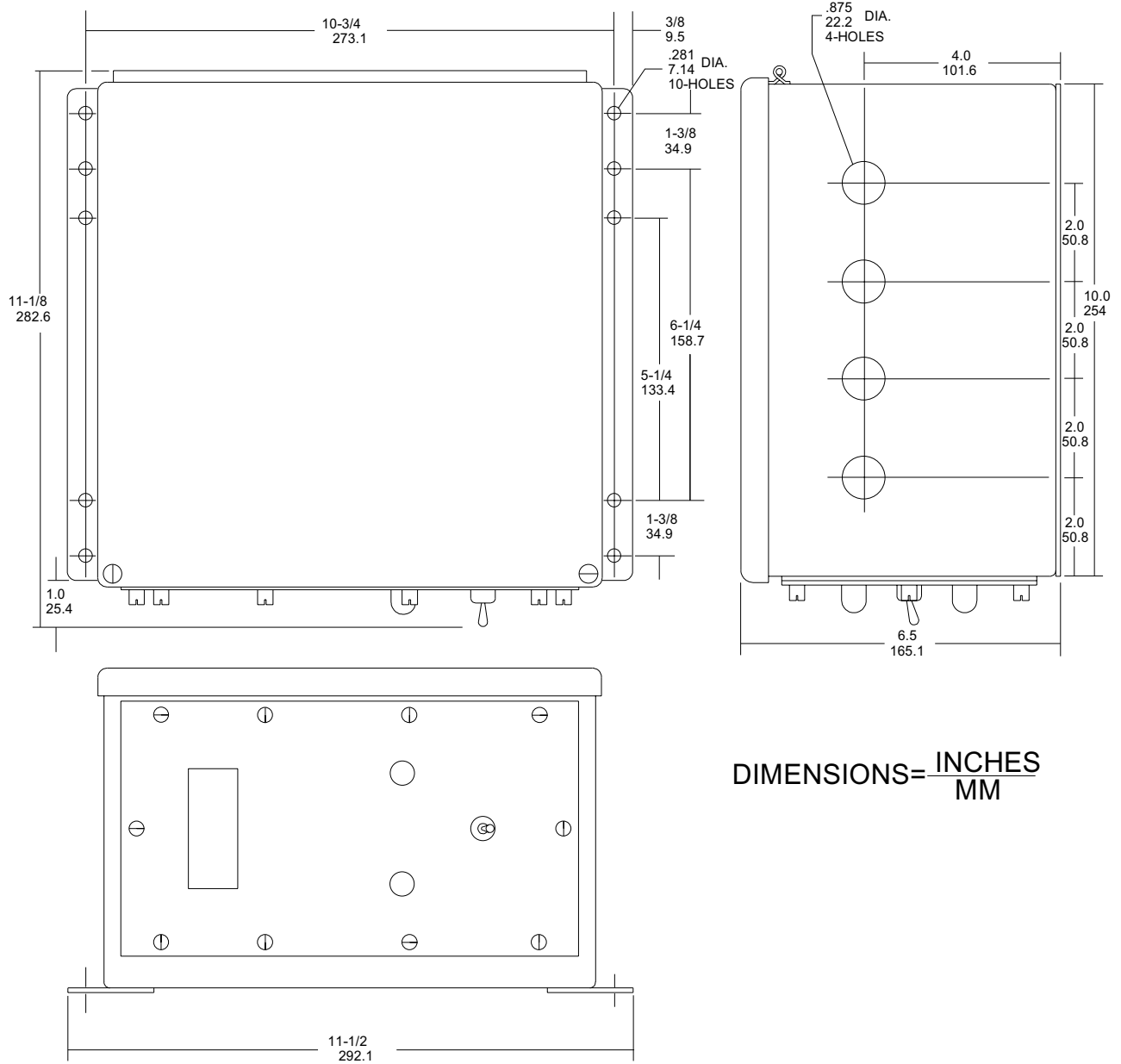


**Figure 6**  
**Location of Parts**

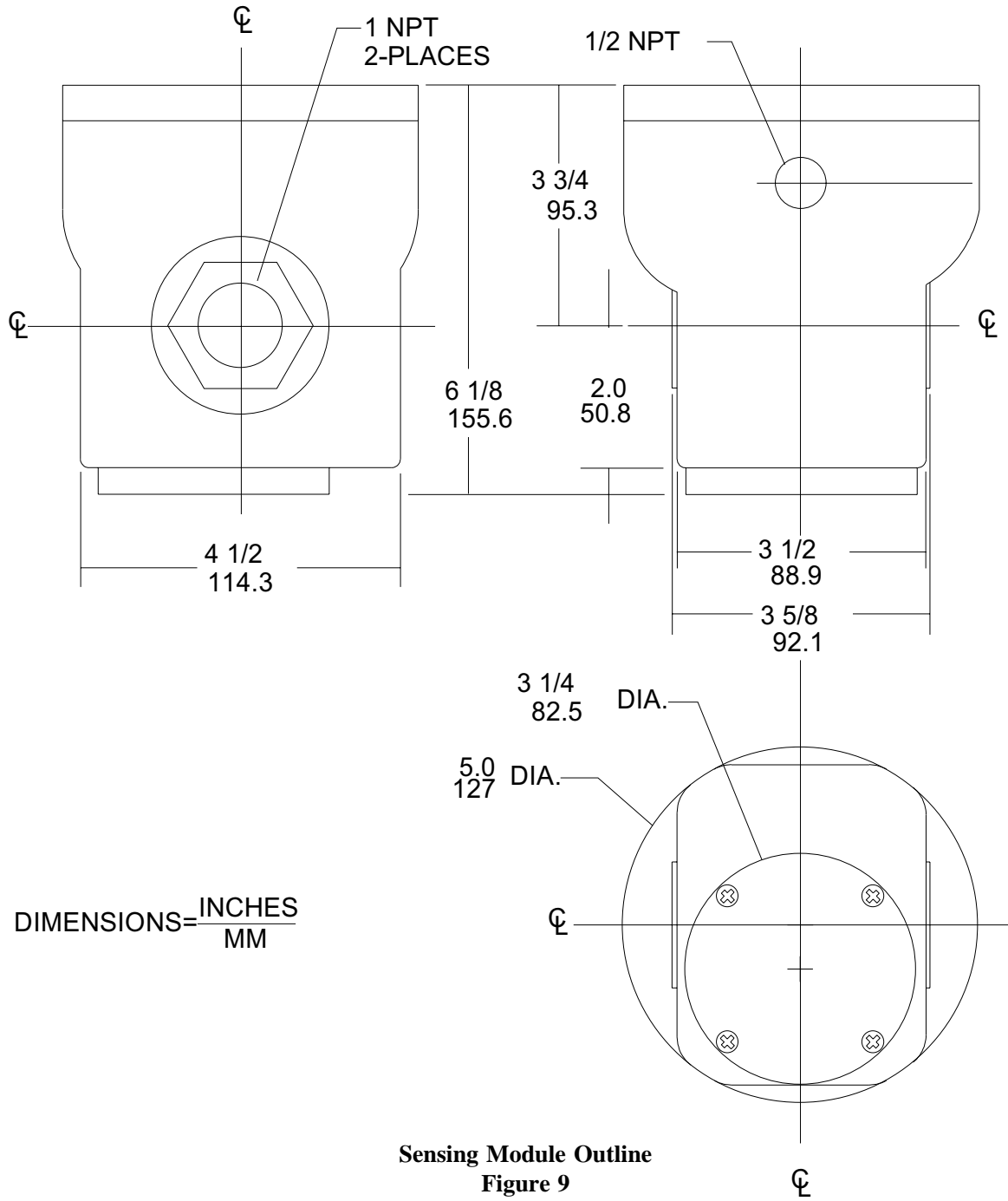




**Sensor Connections**  
**Figure 7**



**Control Module Outline  
Figure 8**



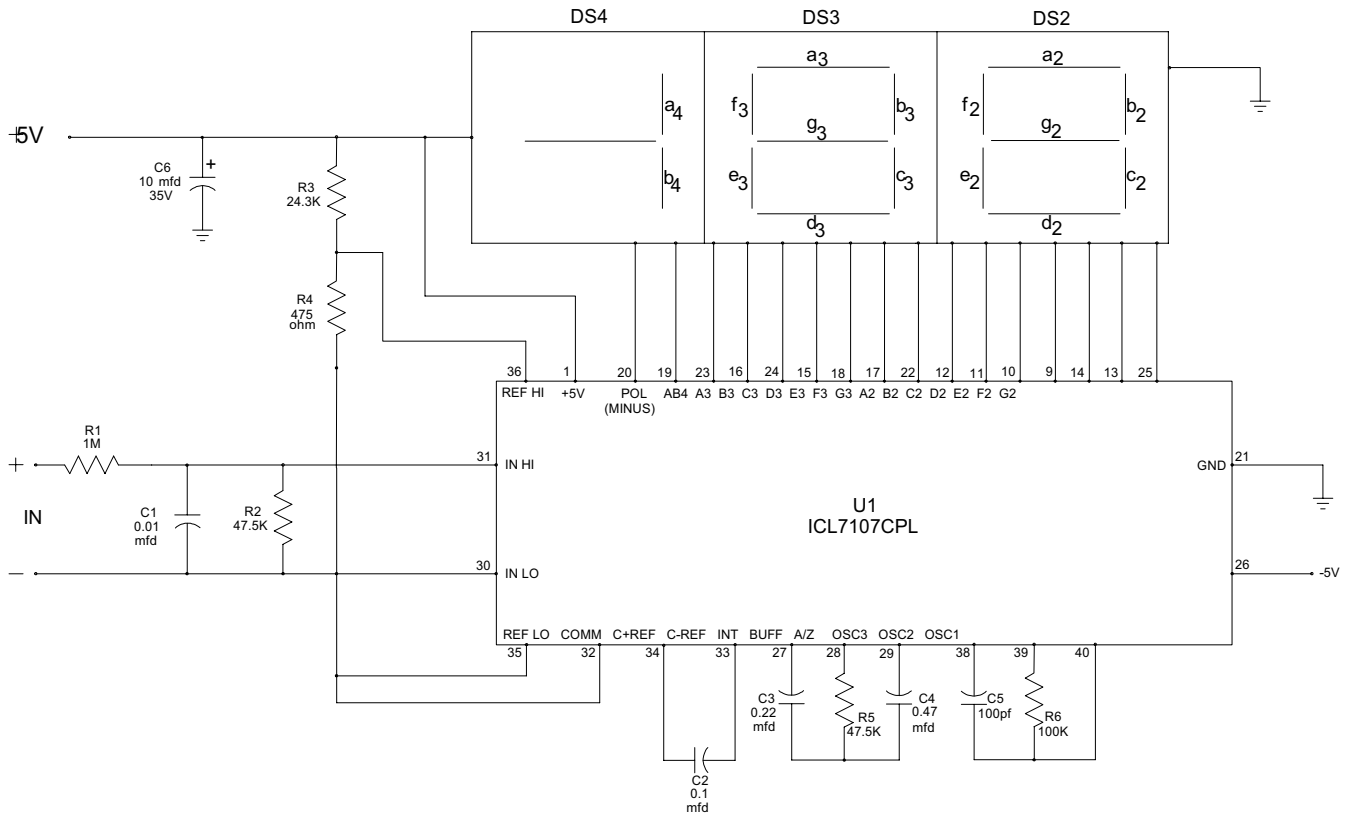


Figure 10  
Digital Display Schematic Drawing

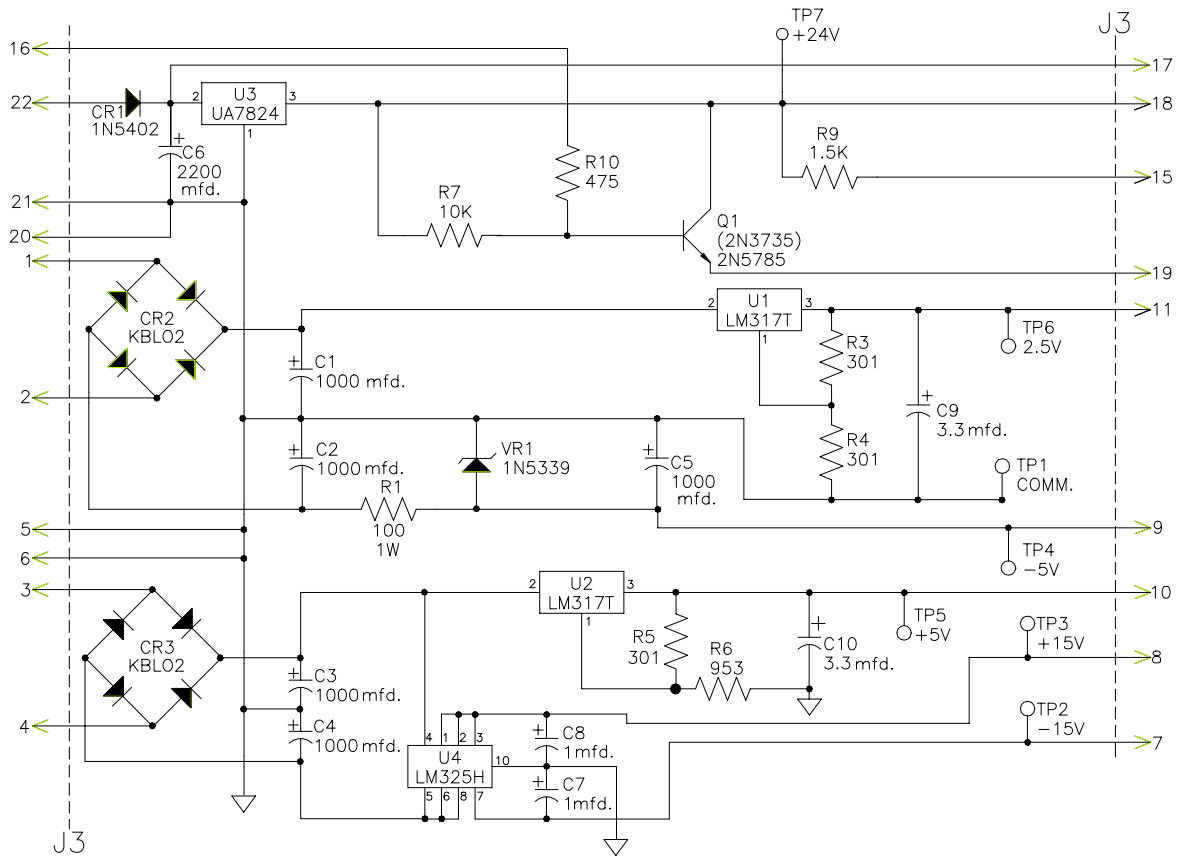


Figure 11  
Power Supply Schematic

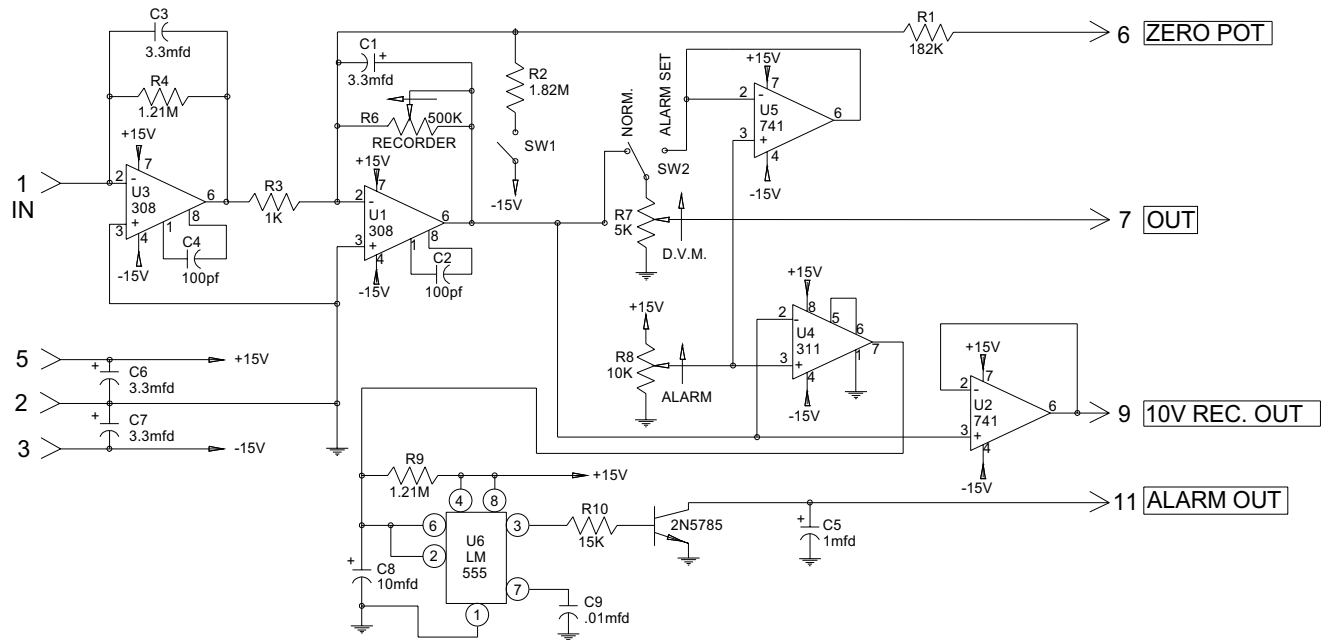


Figure 12  
Amplifier Board Schematic



U.S. Department of Transportation  
United States Coast Guard

# Certificate of Approval

Coast Guard Approval Number: 162.050/3009/1

Expires: Mar 1, 2007

OIL POLLUTION PREVENTION EQUIPMENT

HF SCIENTIFIC INC  
3170 METRO PARKWAY

FORT MYERS FL 33916-7597

Model BA/1 Oil content meter.

Oil content meter analyzing unit manufactured by HF SCIENTIFIC, INC. to drawing no. 88019-C-06 dated 30DEC96. Electronic section of oil content meter manufactured by HF SCIENTIFIC, INC. to drawing no. 88018-B-07 dated 30DEC96.

Identifying Data: The oil content meter is acceptable for use with a 15 ppm bilge alarm in accordance with regulation 16(5).

A copy of this certificate should be carried aboard a vessel fitted with this equipment at all times. IMO Certificates of Type Approval do not expire and are valid for equipment manufactured at any time during the period of validity of this Certificate.

This certificate extends approval number 162.050/3009/1 dated March 23, 1998.

\*\*\* END \*\*\*

THIS IS TO CERTIFY THAT the above named manufacturer has submitted to the undersigned satisfactory evidence that the item specified herein complies with the applicable laws and regulations as outlined on the reverse side of this Certificate, and approval is hereby given. This approval shall be in effect until the expiration date hereon unless sooner canceled or suspended by proper authority.



GIVEN UNDER MY HAND THIS 1<sup>st</sup> DAY OF  
Mar 2002 AT WASHINGTON D.C.

RAYMOND W. MARTIN, CDR  
Chief, Systems Engineering Division  
BY DIRECTION OF THE COMMANDANT, U.S.C.G.

**TERMS:** The approval of the item described on the face of the Certificate has been based upon the submittal of satisfactory evidence that the item complies with the applicable provisions of the navigation and shipping laws and the applicable regulations in Title 33 and/or Title 46 of the Code of Federal Regulations. The approval is subject to any conditions noted on this Certificate and in the applicable laws and regulations governing the use of the item on vessels subject to Coast Guard inspection or on other vessels and boats.

Consideration will be given to an extension of this approval provided application is made 3 months prior to the expiration date of this Certificate.

The approval holder is responsible for making sure that the required inspections or tests of materials or devices covered by this approval are carried out during production as prescribed in the applicable regulations.

The approval of the item covered by this certificate is valid only so long as the item is manufactured in conformance with the details of the approved drawings, specifications, or other data referred to. No modification in the approved design, construction, or materials is to be adopted until the modification has been presented for consideration by the Commandant and confirmation received that the proposed alteration is acceptable.

**NOTICE:** Where a manufacturer of safety-at-sea equipment is offering for sale to the maritime industry, directly or indirectly, equipment represented to be approved, which fails to conform with either the design details or material specifications, or both, as approved by the Coast Guard, immediate action may be taken to invoke the various penalties and sanctions provided by law including prosecution under 46 U.S.C. 3318, which provides:

"A person that knowingly manufactures, sells, offers for sale, or possesses with intent to sell, any equipment subject to this part (*Part B. of Subtitle II of Title 46 U.S.C.*) and the equipment is so defective as to be insufficient to accomplish the purpose for which it is intended, shall be fined not more than \$10,000, imprisoned for not more than 5 years or both."

APPENDIX

TEST DATA AND RESULTS OF TESTS CONDUCTED ON AN  
OIL CONTENT METER IN ACCORDANCE WITH PART 2 OF  
THE ANNEX TO THE GUIDELINES AND SPECIFICATIONS  
CONTAINED IN IMO RESOLUTION MEPC...(33)

Oil Content meter was submitted by HF scientific, inc., Fort Myers, FL

Test location Underwriters Laboratories, 12 Laboratory Dr., Research Triangle Park, NC

Method of sample analysis in accordance with part 2 of MEDC 60 (33)

Samples analyzed by Underwriters Laboratories, Inc.


Environmental testing of the electronic section of the oil content meter has been carried out in accordance with part 3 of the annex to the Guidelines and Specifications contained in IMO resolution MEPC...(33). The equipment functioned satisfactory on completion of each test specified on the environmental test protocol.

Manufacturers' recommendations and information concerning the use of cleaning agents a 1% concentration of the cleansing agent is preferred.

W/9146D/EWP

**APPROVED**  
Subject to conditions in  
Commandant (G-MSE) approval certificate

MAR 0 1 1997

  
R.L. MARKLE  
Chief, Lifesaving and Fire  
Safety Standards Division  
By direction of the Commandant  
United States Coast Guard

**Contaminates Test**

1. Non-oil particulate matter

Meter reading shift with ppm non-oil particulate contaminants mixed with water and light distillate oil added in oil concentrations of:

**Readings (ppm)**

<b>Condition</b>	<b>Measured</b>	<b>Indicated</b>	<b>Remarks</b>
Fresh Water	10.3 ppm	10 ppm	5-5 UL report
6% Salt	10.3 ppm at 39.5 psig 41.2 gpm	25ppm	5-5-94 UL report
6% Salt	10.7 ppm at 60 psig 21.4 gpm	9-11 ppm	5-5-94 UL report
Fresh Water	7.0 ppm	7.0 ppm	5-5-94 UL report
10 ppm air cleaner	7.02 - 7.4 ppm	34-25 ppm	5-5-94 UL report

**Color Test**

2.5 ppm black ink test

pass/fail

**Remarks**

Indicated meter reading 9-10 ppm, with 10 ppm measured.

**APPROVED**  
 Subject to conditions in  
 Commandant (G-MSE) approval certificate

MAR 0 1 1997

*R.L. Markle*  
 R.L. MARKLE  
 Chief, Lifesaving and Fire  
 Safety Standards Division  
 By direction of the Commandant  
 United States Coast Guard

**READINGS (ppm)**

	<b>Indicated</b>	<b>Measured</b>	<b>Grab Sample</b>	<b>Remarks</b>
Calibration	0	0	N/A	Test 1A, UL report 4-28-82
Light Distillate Fuel Oil	15 ppm Alarm	≥ 15 ppm	19.0	Test 1A, UL report 4-28-82
	15ppm Alarm	≥ 15 ppm	17.8	Test 3A, UL report 4-28-82
	15ppm Alarm	≥ 15 ppm	15.2	Test 4A, UL report 4-28-82
	15ppm Alarm	≥ 15 ppm	13.6	Test 4A, UL report 4-28-82
Full Scale	N/A	N/A	N/A	

**TEST**  
**Water Temperature**  
**20.0-24.4°C**  
**RE-ZERO YES/NO**  
**RECALIBRATE YES/NO**

**Response Times**

at 40 ppm injected

**Remarks**

0.72 seconds for alarm to accuate  
 Test 2A, UL Report 4-28-82

W/9146D/EWP

**APPROVED**  
 Subject to conditions in  
 Commandant (G-MSE) approval certificate

MAR 0 1 1997

*R.L. Markle*  
 R.L. MARKLE  
 Chief, Lifesaving and Fire  
 Safety Standards Division  
 By direction of the Commandant  
 United States Coast Guard

**SAMPLE PRESSURE OF FLOW TEST**

Meter reading shift at 50% of normal                    -1.0 ppm                    Test 3A, 50% Flow, 4-28-82 UL report.

Meter reading shift at 200% of normal                    -1.9 ppm                    Test 3A, 120% Flow, 4-28-82 UL report

Deviations from this test should be stated if necessary

Meter reading before shut off                                    +0.2 ppm                    Test 4A, 4-28-82 UL Report

Meter reading after start up (minimum dry period 8 hours)                    -1.4 ppm                    Test 4A, 4-28-82 UL Report

Damage to meter as follows:

NONE

**Utilities Supply Variation Test**

110% voltage effects                    -2.0 ppm at 121 VAC, 60Hz Test 5A, UL report 4-28-82  
+4.1 ppm at 242 VAC, 60Hz Test 5A, UL report 4-28-82

90% voltage effects                    +0.8 ppm at 99 VAC, 60Hz Test 5A, UL report 4-28-82  
+0.5 ppm at 198 VAC, 60Hz Test 5A, UL report 4-28-82

110% air pressure effects N/A

90% air pressure effects N/A

110% hydraulic pressure effects N/A

90% hydraulic pressure effects N/A

Other Comments:

---

---

---

---

---

**APPROVED**  
Subject to conditions in  
Commandant (G-MSE) approval certificate

MAR 0 1 1997  
*R.L. Markle*  
R.L. MARKLE  
Chief, Lifesaving and Fire  
Safety Standards Division  
By direction of the Commandant  
United States Coast Guard

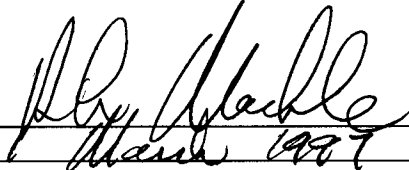
Calibration and Zero Test

Calibration drift                      -2.0 to +2.7 ppm

Test 7A, 4-28-82 UL Report

Zero drift                                0 ppm

Test 7A, 4-28-82 UL Report

Signed   
Date March 1997

Official Stamp

(Official stamp or equivalent identification and the date of approval  
to be placed on all pages of the test protocol.)

\*\*\*

**APPROVED**  
Subject to conditions in  
Commandant (G-MSE) approval certificate

MAR 0 1 1997

  
R.L. MARKLE  
Chief, Lifesaving and Fire  
Safety Standards Division  
By direction of the Commandant  
United States Coast Guard

