

DESCRIPTION

Heavy duty shower system with chrome plated HydroGuard shower valve, triple duty checkstops with strainer, chrome head riser, and adjustable brass shower head. Available with HydroGuard 410 Series pressure balancing valve or HydroGuard T/P® Series e420 combination valve.

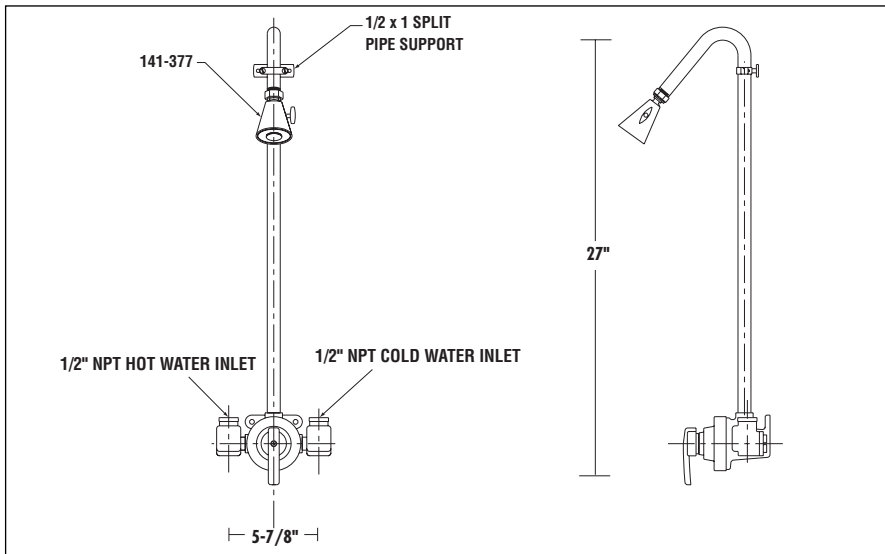

SPECIFICATIONS*

Connections	1/2" NPT
Valve Capacity (@45 psi ΔP)5.25 gpm (420)/6.0 gpm (410)
Maximum Operating Pressure	125 psi
Temperature Limit Stop	Standard
Shower Valve ComplianceADA/Barrier Free, ASSE 1016 Compliant, CSA B125 Approved
ShowerheadChrome-plated, adjustable 2.5 gpm
CheckstopsChrome-plated, brass, triple duty

*See individual shower data sheets for more information.

HydroGuard Exposed Shower Systems

Order Code

410 HydroGuard Exposed (Pressure Balancing)455 419FK0
420 HydroGuard Exposed (Thermostatic)455 423FK0

Engineering Approval

Project _____
 Contractor _____
 Architect/Engineer _____