

POWERSTATION™

Water Tempering Recirculation Systems



Single-Valve Powerstation

Description ■

Powerstation is a complete, fully assembled water tempering system, designed to provide safe water throughout commercial and institutional facilities. Powerstation features the HydroGuard® e430 or 1430 tempering series valve with advanced thermal actuation technology. Each Powerstation is mounted on heavy-duty, welded struts and is factory tested as a complete system. Each POWERSTATION includes an engineer specified circulator, GFCI outlet, combination temperature/pressure gauges and Powers' triple-duty checkstops. Optional equipment includes an Aquastat and/or Powers' exclusive automatic balancing valve and internal by-pass loop for fast and easy set-up.

Specifications ■

Maximum Pressure Differential	100 psi (689 kpa)
Maximum Static Pressure	125 psi (862 kpa)
Maximum Hot Water Temperature	200°F (93°C)
Minimum flow*	0.5 gpm (2.0 lpm)
Minimum flow at which valve will control to ASSE 1017 requirements.	
431	4.0 gpm (15 lpm)
432	7.0 gpm (26 lpm)
433	10.0 gpm (38 lpm)
434	15.0 gpm (57 lpm)
1432	1.5 gpm (6 lpm)
1434	5.0 gpm (19 lpm)
Approach Temperature	15°F (8°C)
Temperature Adjustment Range	40° - 160°F (4° - 71°C)
<i>*Minimum flow when POWERSTATION is installed at or near hot water source with re-circulated tempered water with a properly sized continuously operating re-circulating pump.</i>	

Table 1 — Flow Capacity When Tested To ASSE 1017 Standard ■

Valve	CV 1 psi (7 kpa)	Minimum Flowrate	Pressure Differential						
			5 psi (35 kpa)	10 psi (69 kpa)	15 psi (103 kpa)	20 psi (138kpa)	30 psi (207 kpa)	45 psi (310 kpa)	60 psi (414 kpa)
431	3.73	4.0 gpm (15.0 lpm)	8.3 gpm (31.0 lpm)	11.8 gpm (45.0 lpm)	14.4 gpm (55.0 lpm)	16.7 gpm (63.0 lpm)	20.4 gpm (77.0 lpm)	25.0 gpm (95.0 lpm)	28.9 gpm (109.0 lpm)
432	6.71	7.0 gpm (26.0 lpm)	15.0 gpm (57.0 lpm)	21.2 gpm (80.0 lpm)	26.0 gpm (98.0 lpm)	30.0 gpm (114.0 lpm)	36.8 gpm (139.0 lpm)	45.0 gpm (170.0 lpm)	52.0 gpm (197.0 lpm)
433	11.93	10.0 gpm (38.0 lpm)	26.7 gpm (101.0 lpm)	37.7 gpm (143.0 lpm)	46.2 gpm (175.0 lpm)	53.4 gpm (202.0 lpm)	65.3 gpm (247.0 lpm)	80.0 gpm (303.0 lpm)	92.4 gpm (350.0 lpm)
434	18.63	15.0 gpm (57.0 lpm)	41.7 gpm (158.0 lpm)	58.9 gpm (223.0 lpm)	72.2 gpm (273.0 lpm)	83.3 gpm (315.0 lpm)	102.0 gpm (386.0 lpm)	125.0 gpm (473.0 lpm)	144.3 gpm (546.0 lpm)
1432	5.96	1.5 gpm (6.0 lpm)	13.3 gpm (50.0 lpm)	18.8 gpm (71.0 lpm)	23.1 gpm (87.0 lpm)	26.7 gpm (101.0 lpm)	32.6 gpm (123.0 lpm)	40.0 gpm (151.0 lpm)	46.2 gpm (175.0 lpm)
1434	14.91	5.0 gpm (19.0 lpm)	33.3 gpm (126.0 lpm)	47.2 gpm (179.0 lpm)	57.8 gpm (219.0 lpm)	66.7 gpm (252.0 lpm)	81.7 gpm (309.0 lpm)	100.0 gpm (379.0 lpm)	115.5 gpm (473.0 lpm)

Dimensions & Legends ■

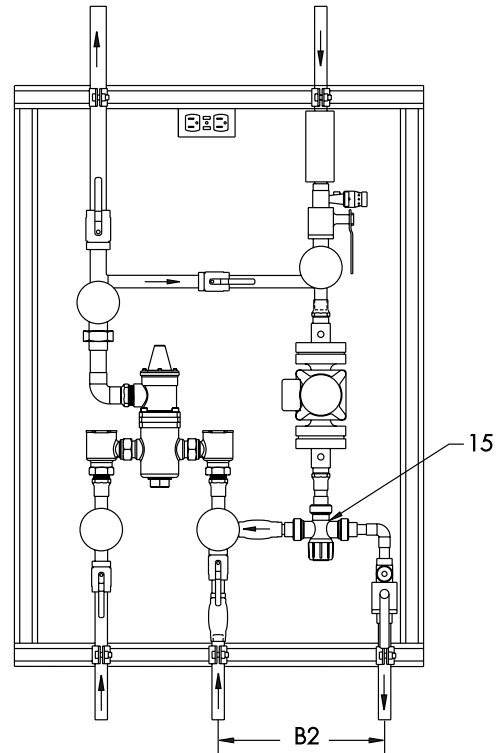
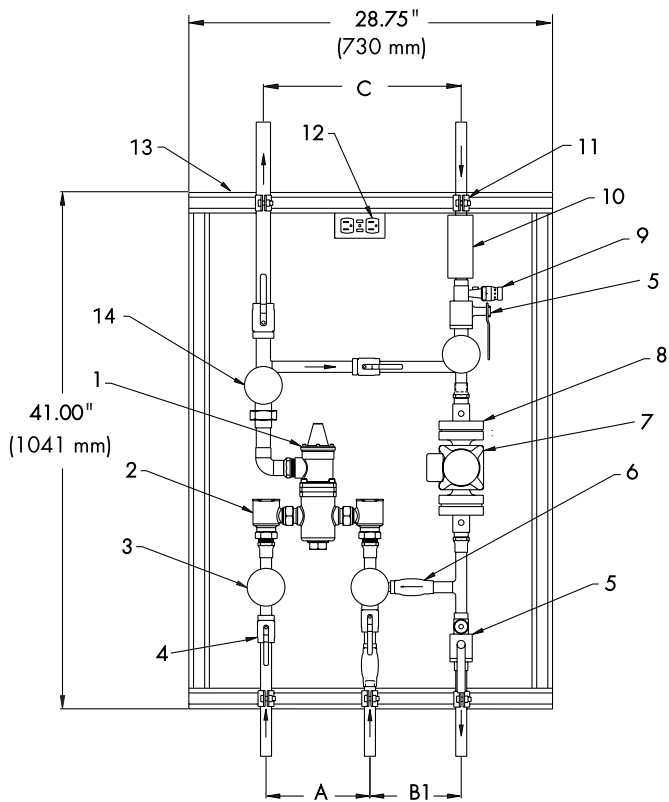

	431	432	433	434	1432	1434
A	8-3/16" (208 mm)	8-3/16" (208 mm)	10-1/4" (260 mm)	10-1/4" (260 mm)	8-3/16" (208 mm)	10-1/4" (260 mm)
B1	7-3/4" (197 mm)	7-3/4" (197 mm)	7-3/4" (197 mm)	7-3/4" (197 mm)	7-3/4" (197 mm)	7-3/4" (197 mm)
B2	11-1/8" (283 mm)	11-1/8" (283 mm)	11-1/8" (283 mm)	11-1/8" (283 mm)	11-1/8" (283 mm)	11-1/8" (283 mm)
C	16-1/4" (413 mm)	16-1/4" (413 mm)	18-1/4" (464 mm)	18-1/4" (464 mm)	16-1/4" (413 mm)	18-1/4" (464 mm)

Item Number	Item Description	Options	Quantity Required
1	THERMOSTATIC VALVE	SEE ORDER CODE	1
2	TRIPLE DUTY CHECK-STOP	Std	2
3	TEMPERATURE/PRESSURE GAUGE	Std	3
4	BALL VALVE	Std	4
5	BALL VALVE w/DRAIN	Std	2
6	CHECK VALVE	Std	2
7	CIRCULATOR	APPLICATION SPECIFIC	1
8	ISOLATION FLANGE	Std	2
9	VACUUM BREAKER	Std	2
10	AQUASTAT	OPTIONAL	1
11	PIPE STRAPS	Std	Typical
12	GFCI OUTLET	Std	1
13	WELDED MOUNTING STRUTS	Std	1
14	THREE COLOR THERMOMETER	Std	1
15	AUTOMATIC BALANCING VALVE	OPTIONAL	1

Piping Diagrams ■

Diagram 1. Low temperature hot water recirculation diagram.

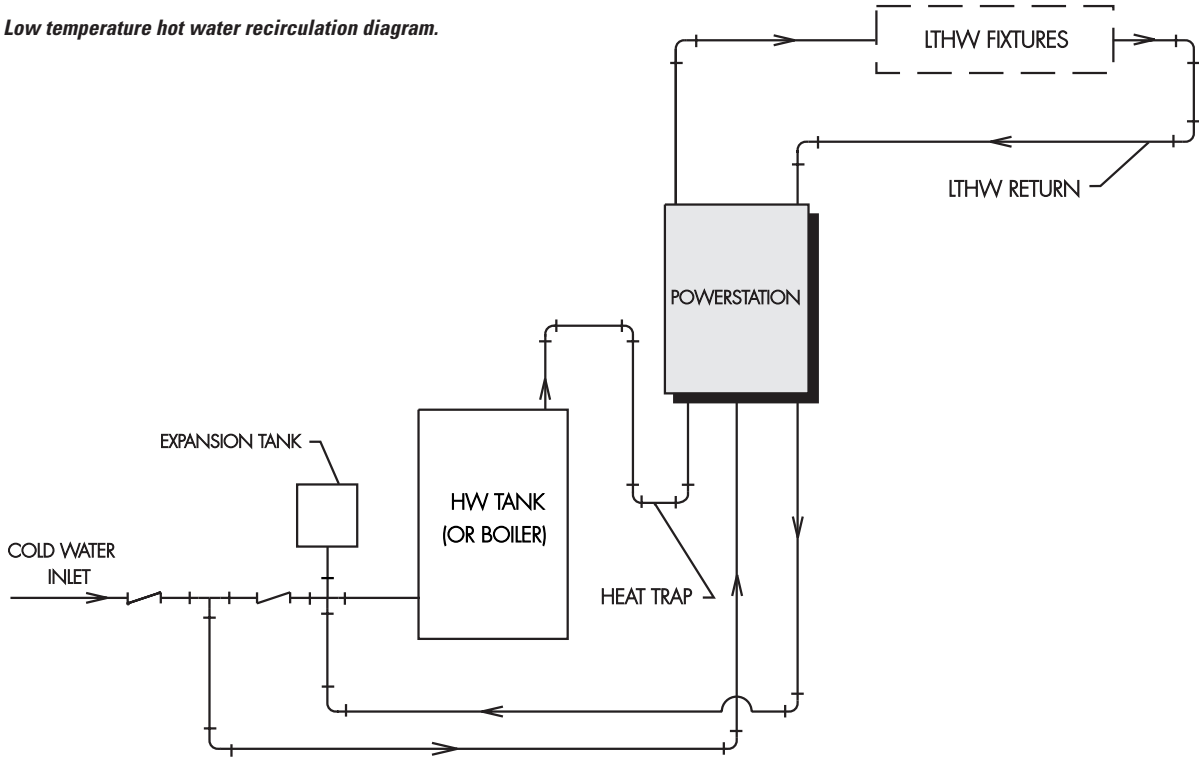
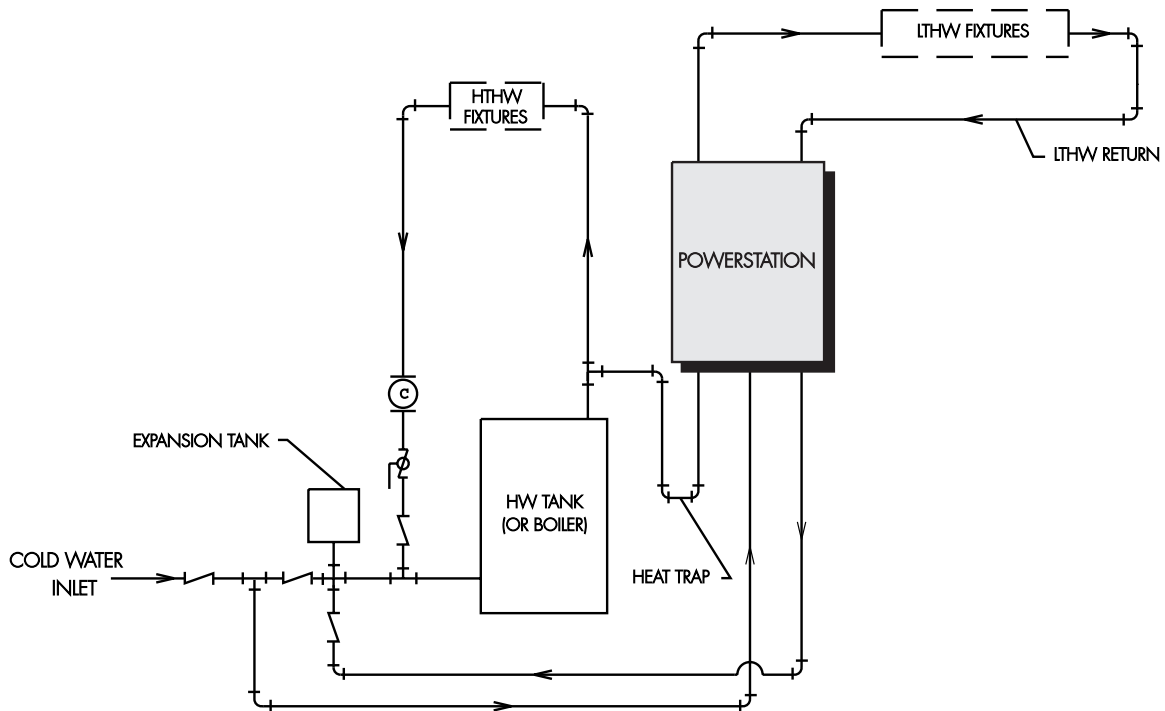

Diagram 2. Low temperature hot water recirculation diagram with separate high temperature hot water recirculation.



Installation & Set up ■

1. Flush all piping thoroughly before installing.
2. Follow piping diagram 1 or 2 to connect the Powerstation.
3. Check for leaks.
4. Set up is as follows:

For all systems ■

1. Close B3, B4, and B6.
2. Close D1 and D2.
3. Open B1, B2, and B5.
4. Connect hose to D2 and run to a drain.
5. Open D2 with a screwdriver and verify flow to drain is greater than minimum flow shown in Table #1.
6. For systems with an automatic balancing valve, adjust the knob to the full hot position (forces the water through the hose).
7. If flow rate is less than in Table 1, turn pump P1 on.
8. Let valve run until readings on inlet gauges T/P1 & T/P2 is steady.
9. Adjust temperature of mixing valve to desired set point (read temperature on T1).
10. Lock temperature adjustment knob/screw in place.
11. Turn off pump.
12. Close B5 and open B4.
13. Open D1 to purge air out of recirculation line.
14. Close D1 when you begin to get water.
15. Open B6 and wait until T/P3 reaches the maximum recirculation temperature (must be less than the mixing valve setpoint).
16. Skip to the type of recirculation used below.

AquaStat ■

1. Close D2.
2. Apply power to pump P1.
3. Set the pump on and off temperatures.
4. As the recirculation temperature was already set to its' maximum, the pump/aquastat will remain off until the temperature cools to the low trip point.
5. Wait until the recirculation line cools to the low point.
6. Verify the pump turns on at this point.
7. Open B3.
8. Verify recirculation line heats back up and turns pump off at the maximum setting from step 3.
9. The system is now set.

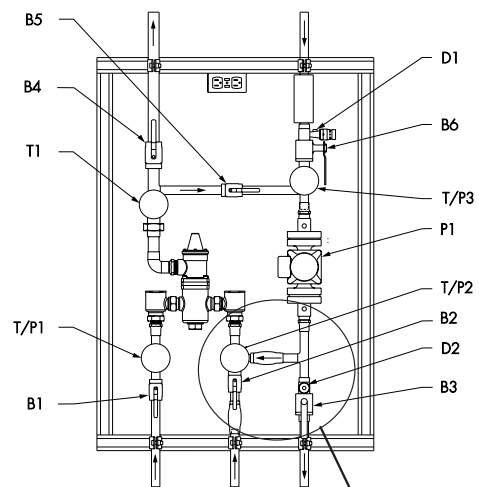

For Automatic Balancing Valve Option.

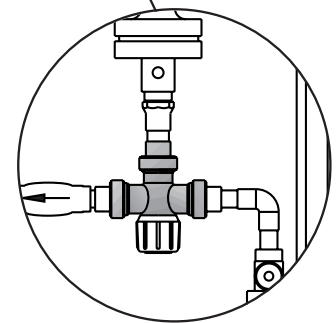

Continuous Recirculation ■

1. Close D2.
2. Open B3 approximately 10%.
3. Allow time for recirculated water to travel around the loop.
4. If the temperature at T/P3 begins falling, you will need to open B3 another 10%.
5. If the temperature at T/P3 begins to rise, you will need to close the handle 5%.
6. Repeat steps 4-6 until the temperature at T/P3 is stable (less than the setpoint of the mixing valve).
7. The system is now set.

Continuous Recirculation with Automatic Balancing Valve ■

1. For systems with an automatic balancing valve, adjust the knob to the full cold position (restricts the flow of water through the hose to a trickle)
2. Slowly turn the automatic balancing valves knob towards the hot position until you just start to get water through the hose. At this point it is set to the temperature shown on T/P3.
3. Close D2.
4. Open B3.
5. The system is now set.

In all cases, verify the system maintains temperature before leaving the mechanical room. You must allow for the system to reach the steady state conditions.

Parts Kits ■

REPAIR KITS for e430

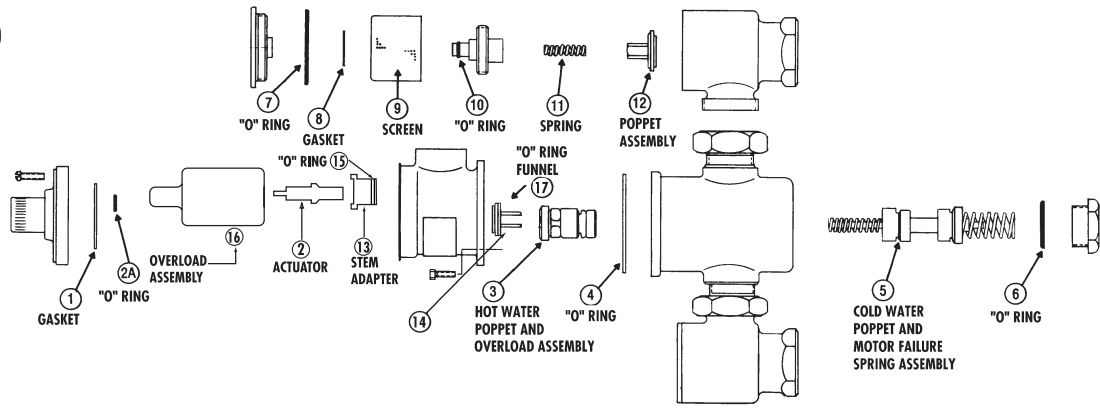

PART DESCRIPTION	REPAIR KIT INCLUDES:	431 Part No.	432 Part No.	433 Part No.	434 Part No.
Thermal Actuator	1, 2, 4, 13, AND 15	390-037	390-036	390-065	390-066
Strainer Replacement	7, 8, 9, and 10	230-134	230-134	230-136	230-136
Checkstop Replacement	7, 8, 10, 11, and 12	230-135	230-135	230-137	230-137
Gasket and Disc Replacement	1, 2A, 4, 6, 7, 8, 10, and 12	390-294	390-298	390-302	390-306
Mixing Valve Replacement	3, 4, 5, and 6	390-067	390-068	390-069	390-070

Strainer and Checkstop Repair Kits contain parts for one (1) pair.
Repair Kits containing "O" Rings include silicone gel for use on "O" Rings during installation.

REPAIR KITS for 1430

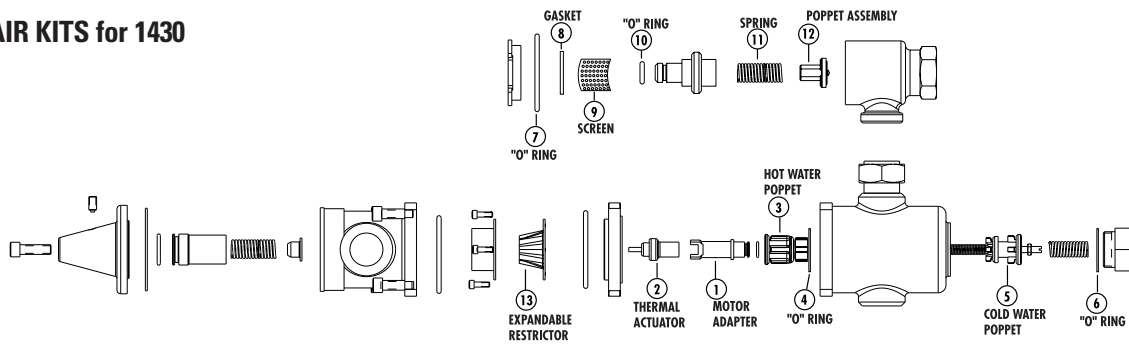

PART DESCRIPTION	REPAIR KIT INCLUDES:	1432	1434
Hi-Lo Motor Replacement Kit	13 and 2	390-500	390-543
Strainer Replacement	7, 8, 9, and 10	230-134	230-136
Checkstop Replacement	7, 8, 10, 11, and 12	230-135	230-137
Gasket and Disc Replacement	1, 4, 6, 7, 8, 10, and 12	390-298	390-306
Mixing Valve Replacement	1, 3, 4, 5, and 6	390-068	390-070

Strainer and Checkstop Repair Kits contain parts for one (1) pair.
Repair Kits containing "O" Rings include silicone gel for use on "O" Rings during installation

Maintenance and Troubleshooting ■

What to look for:

1) Flow of water is less than desired.....

- Stop valves or supply to the HydroGuard valve not fully open.
- Clogged checkstop strainer screen.
- Accumulation of lime deposits around valve seats.
- Low supply pressure or unusual supply temperature.

2) The flow of water is completely shut off.....

- Stop valves or supply valve completely closed.
- Valves downstream from HydroGuard completely closed.
- Loss of either hot or cold water temperature.

3) Discharge temperature varies.....

- Very large restriction in the outlet flow.
- Very large drop in inlet pressure.
- Very large fluctuation of hot water supply temperature.
- Worn valve seat.
- Minimum flow requirement not achieved.

Ordering Information ■

Rough	inlet (inches)	outlet (inches)
1432	3/4	1
1434	1-1/4	1-1/2
431	3/4	3/4
432	3/4	1
433	1-1/4	1-1/4
434	1-1/4	1-1/2

Controls

- None
- Aquastat
- AquaSentry2
- Aquastat & AquaSentry2

Balancing Valve

- None
- Circuit Setter
- Automatic Balancing Valve
- Circuit Setter & Automatic Balancing Valve

Return Pipe Size

- 1/2"
- 3/4"
- 1"
- 1-1/4"
- 1-1/2"

Assigned by Factory

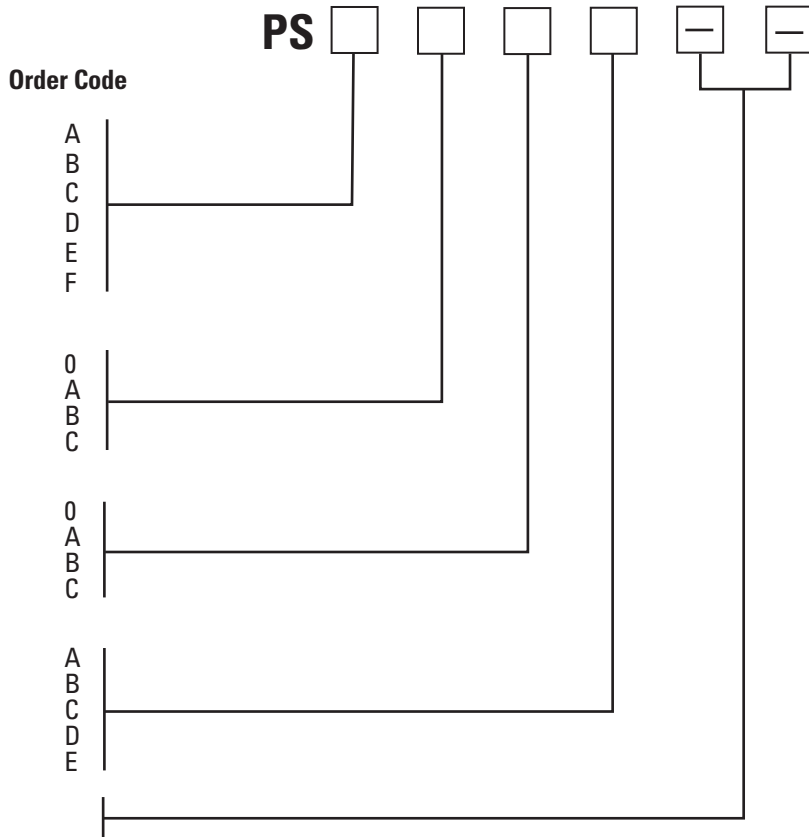

Pump Information:

Pump Manufacturer: _____

Their Part No # * _____

* if the pump is not selected or if you are using an Automatic Balancing Valve (ABV) you must provide the following:

System Head Loss _____

Required Flow to Maintain Recirculating Temp. _____

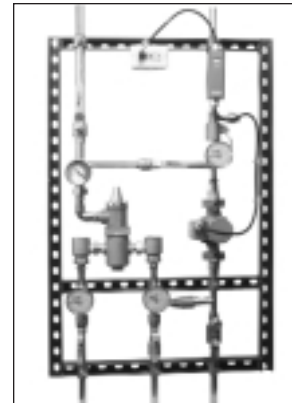

Typical Specification ■

Water temperature control system will include a single thermostatic mixing valve capable of maintaining water temperature to within 15°F (8°C) above set point within the range of 40°F to 160°F (7° to 71°C). Valve must compensate for temperature fluctuations due to inlet temperature or pressure changes. Valve will be of bronze body with triple-duty check stops and must have an advanced, paraffin based thermal actuator to guarantee precise control when tested in accordance with ASSE 1017 and CSA B125.

Control system will be mounted on a heavy-duty welded struts with corrosion resistance coating, and factory tested as a complete unit. System will include an internal by-pass loop for fast and easy set-up. It will also includes GFCI protection, engineer specified circulator and combination temperature/pressure gauges. The control system will be a Powers' POWERSTATION series PS. Any alternate must have a written approval prior to bidding.

CALIFORNIA PROPOSITION 65 WARNING

WARNING: This product contains chemicals known to the State of California to cause cancer and birth defects or other reproductive harm. (California law requires this warning to be given to customers in the State of California.) For more information: www.wattsind.com/prop65

Engineering Approval

Project _____

Contractor _____

Architect/Engineer _____



POWERS™

USA Phone: 800.669.5430
Canada Phone: 888.208.8927
www.powerscontrols.com