

For Snowmelt Applications

Job Name _____
 Job Location _____
 Engineer _____
 Approval _____

Contractor _____
 Approval _____
 Contractor's P.O. No. _____
 Representative _____

PM-224 Sensor/Controller

Remote snow/ice sensor

The PM-224 is a 24 volt, self contained snow and ice detector. Each PM-224 can be set to operate within a range of 22-28 V. The integrated snow sensor is heated to allow for snow, ice, or freezing rain to melt, allowing proper detection of environmental conditions.

Specifications

Supply Voltage	22 - 28 VAC
Trigger Temperature Range (TT)	34°F to 44°F
Configuration Modes	Snow Only Rain Only Snow or Rain
Delay Settings (post melting)	30 to 90 minutes 2 to 6 hours
Low Temperature Cutoff (LTC)	Prevents system operation when Ambient Temperature (AT) is below 15°F
Operation Modes	Automatic Standby/Reset Manual

Installation

The PM-224 must be installed in a location that exposes the moisture grid to a clear view of the sky and any precipitation. **Note: The unit should not be mounted directly under eaves, overhangs, or other obstructions that can block precipitation from reaching the moisture grid.**

Do not install the sensor close to the ground, or any other location, that can cause the sensor to be buried in snow.

Mount the PM-224 outdoors, away from furnace vents, dryer vents, and other sources of heat. The PM-224 can be mounted to a free-standing conduit or by using the mounting holes in each corner of the enclosure. Do not drill holes in the enclosure.

Wire the controller in accordance to the provided schematics.

Standards and Listings



Watts product specifications in U.S. customary units and metric are approximate and are provided for reference only. For precise measurements, please contact Watts Technical Service. Watts reserves the right to change or modify product design, construction, specifications, or materials without prior notice and without incurring any obligation to make such changes and modifications on Watts products previously or subsequently sold.

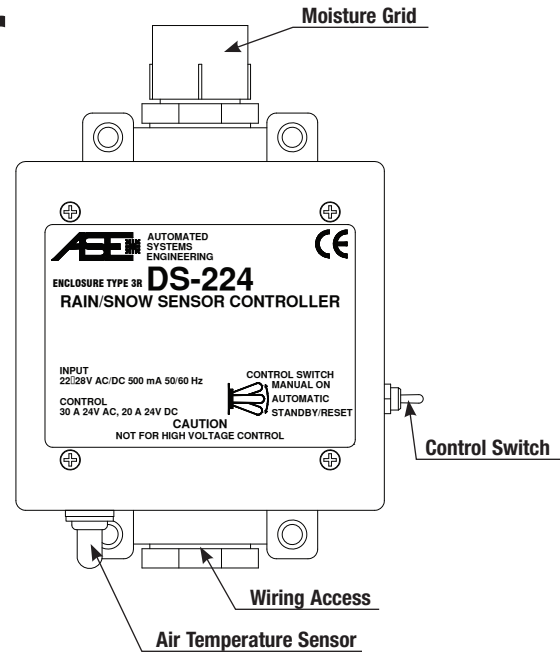

PM-224 provides integrated air and moisture detection within a rainproof and ice-resistant enclosure.

Product Options

Description	Order #
PM-224 Sensor/Control	81011700

⚠ WARNING: General Safety Instructions

- THIS UNIT SHOULD BE INSTALLED ONLY BY QUALIFIED PERSONNEL!**
- Disconnect all power from the control, or any associated equipment, before opening the front cover plate.
- Limit input voltage to 22-28 VAC/VDC
- To avoid fire hazard, replace fuse **only** with 2 Amp 32 V or 250 V 3AG fast acting fuse.
- Do not drill holes through the electrical enclosure for mounting. Mount the control to a free-standing conduit or via the pre-determined mounting holes.
- Ensure front cover gasket is properly installed when replacing cover.



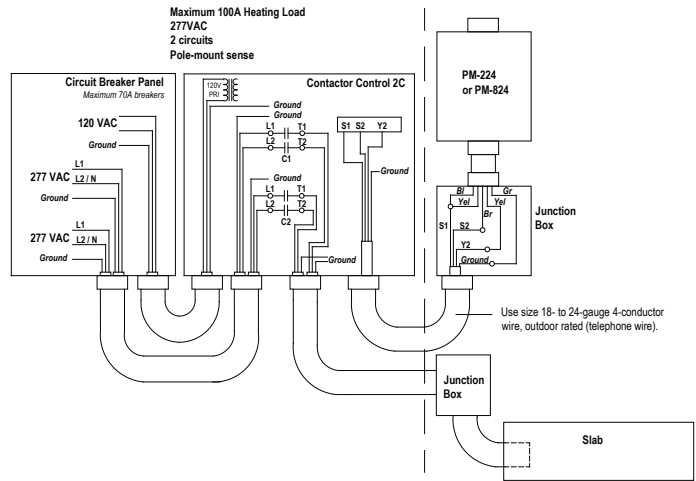
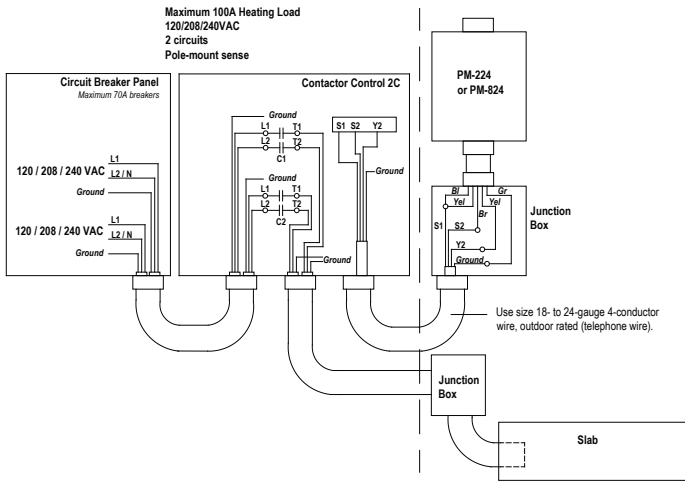

Recommended Switch Settings							
Function	Trigger	LD Off	LD on	LTC	DEL	RAIN	SNOW
Snow sensor w/o LTC	TT>AT	2 min	2 min	OFF	OFF	OFF	ON
Snow sensor w/LTC	TT>AT>15°F	2 min	2 min	ON	OFF	OFF	ON
Snow controller w/o LTC	TT>AT	30-90 min	2-6 hr	OFF	ON	OFF	ON
Snow controller w/LTC	TT>AT>15°F	30-90 min	2-6 hr	ON	ON	OFF	ON

Do Not set the Rain switch to "ON". Possible overheating of the snowmelt cables may result.

