

## For Snowmelt Applications

Job Name \_\_\_\_\_

Contractor \_\_\_\_\_

Job Location \_\_\_\_\_

Approval \_\_\_\_\_

Engineer \_\_\_\_\_

Contractor's P.O. No. \_\_\_\_\_

Approval \_\_\_\_\_

Representative \_\_\_\_\_

# ProMelt Contactor Panels

## For ProMelt CP-50, CP-100, CP-200, and CP-200EX Panels

The CP-50, CP-100, CP-200, and CP-200EX are turn-key panels for activating a ProMelt snow melting system when used in conjunction with the ProMelt series of controls. They allow simple connection from the circuit breaker panel and have a manual override timer and heating indicator. The CP-200EX is an "extension" panel that connects to one of the other panels and allows additional circuits to be controlled.

### Specifications

CP-50, CP-100, CP-200 Specifications		
Terminals		Wiring Type
L1, L2 T1, T2	120, 208, 240, 277 VAC	12 AWG (Minimum)
Y1, Y2	Class 2, 24 VAC	18 AWG (Minimum)
R1, R2		
S1, S2		
Compatible Sensors	PM-224 PM-824 PM-HSC5	

CP-200EX Specifications		
Terminals		Wiring Type
L1, L2 T1, T2	120, 208, 240, 277 VAC	12 AWG (Minimum)
R1, R2	Class 2, 24 VAC	18 AWG (Minimum)

### Features

Each ProMelt system can be used with a wide variety of moisture/precipitation sensors, including the following:

Slab Mounted: PM-HSC5

Pole/wall Mounted: PM-224 and PM-824

Each sensor option is designed to operate a single system. Use a dedicated sensor and CP Control group for each snow melt zone.

CP series of controls can be used directly with any ProMelt cable or mat system. Power is connected directly to each contactor in the control and come pre-wired to the included transformer, terminal blocks, and the coil terminals on the provided contactors. It is not recommended to unwire, or tamper with existing wiring without pre-authorization from the factory.

CP-200EX modules provide an additional 200 amp capacity for any CP Series control. Each CP-200EX contactor needs to be wired directly to a dedicated circuit.



The ProMelt Contactor Control Panel is available in four configurations. CP-50 (single contactor), CP-100 (dual contactors), CP-200 (quad contactors), and CP-200EX (extension module).

### Product Options

Description	Order #
Contactors Pro CP-50	81012215
Contactors Pro CP-100	81012216
Contactors Pro CP-200	81012217
Contactors Pro CP-200EX	81012218

### ⚠ WARNING: General Safety Instructions

1. THIS UNIT SHOULD BE INSTALLED ONLY BY QUALIFIED PERSONNEL!
2. Disconnect all power from the control before opening the front cover plate.

**ProMelt**<sup>TM</sup>  
Electric Snow and Ice Melting

Watts product specifications in U.S. customary units and metric are approximate and are provided for reference only. For precise measurements, please contact Watts Technical Service. Watts reserves the right to change or modify product design, construction, specifications, or materials without prior notice and without incurring any obligation to make such changes and modifications on Watts products previously or subsequently sold.

# Installation

These panels must be installed in accordance with local building codes, the National Electrical Code, or Canadian Electrical Code by qualified persons.

**Disconnect power from all circuits prior to making any connections.**

**Do not energize circuits until all connections are made and all ProMelt mats/cables are fully installed and covered as required.**

Read and follow the installation instructions for both the ProMelt snow-melt mat/cable and the ProMelt sensor for additional information.

Mount the panel indoors on a wall or equivalent. Do not place in a confined air space where heat is not able to escape, such as a small closet.

Properly secure the panel to the wall using the mounting holes provided.

Wire the panel according to the provided schematics.

A GFCI type circuit breaker **must be used** to protect each ProMelt circuit. Size circuits for 125% of the load.

This panel must be bonded to ground, as well as all conduit, junction boxes and other associated items per local code.

## Models CP-50, CP-100, and CP-200

1. Provide 120, 208, 240, or 277 VAC circuits to the panel contactor(s) **L1 and L2** terminals as required by the rating of the ProMelt snow melting mats/cables connected to this circuit. As shown in the wiring schematics, the panel draws internal power from Contactor **C1** terminals, so make sure power is supplied to this contactor.

2. For 120, 208, and 240 VAC systems, connect the transformer **COM** lead wire to contactor **C1** terminal **L1**. Connect the transformer lead wire matching the contactor voltage supplied to **C1** terminal **L2**.

**⚠ CAUTION: Incorrect voltage supplied to the transformer may cause damage, fire, or shock.**

3. For 277 VAC systems, a separate 120 VAC circuit will need to be supplied to the transformer 120 VAC and **COM** lead wires directly. This may be a standard 15 A or 20 A circuit.
4. Use outdoor rated 4-conductor cable to make connections between this panel and the sensor selected. See the wiring schematic and instructions provided with the sensor for proper connections. Connect to terminal block terminals **S1, S2, and Y2** and also to the grounding bar. This will be a Class 2, 24 VAC circuit.
5. Make wire connection between the contactor **T1 and T2** terminals and the ProMelt mats/cables.

## Models CP-200EX

This panel is designed to be used in conjunction with a CP-50, CP-100, or a CP-200 Control Panel. Follow the steps below for proper operation:

1. Provide 120, 208, 240, or 277 VAC circuits to the panel contactor(s) **L1 and L2** terminals as required by the rating of the ProMelt snow melting mats/cables connected to this circuit.
2. Use a 2-conductor cable to make connections between terminals **R1 and R2** in this panel and terminals **R1 and R2** in the main CP-50, CP-100, or CP-200 panel. This will be a Class 2, 24 VAC circuit.
3. Make wire connection between the contactor **T1 and T2** terminals and the ProMelt mats/cables.

Control	No. Contactors	Max. Amp Load
Contactor Pro CP-50	1	50
Contactor Pro CP-100	2	100
Contactor Pro CP-200	4	200
Contactor Pro CP-200EX	4	200

Primary Voltage	Lead Colors
120 Volts	Black & White
208 Volts	Black & Red
240 Volts	Black & Orange

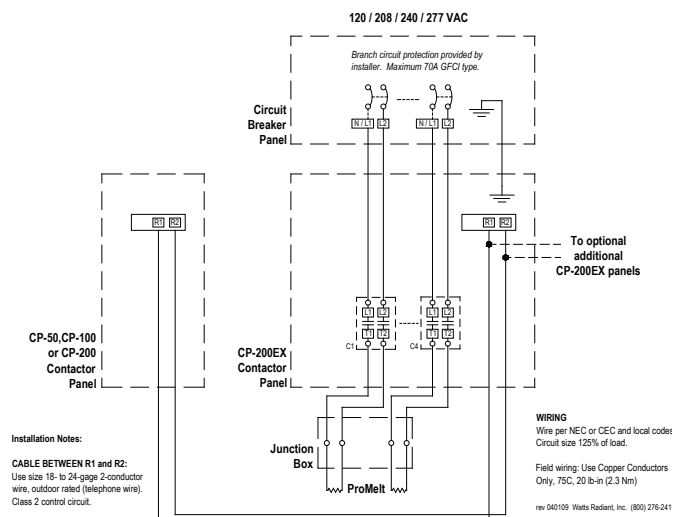
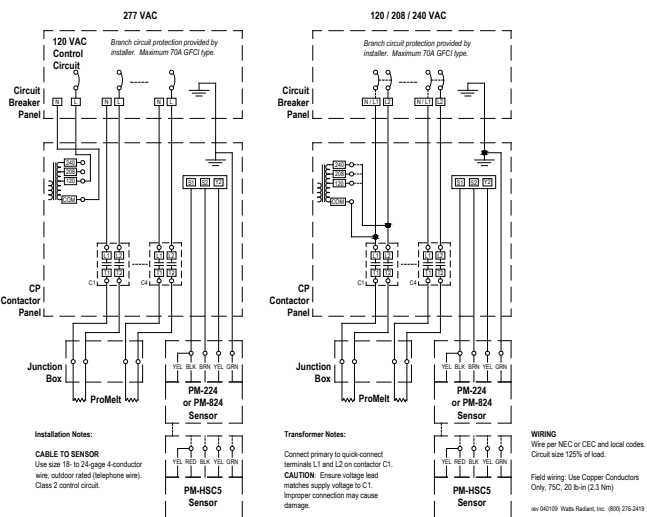

USA: 4500 East Progress Place, Springfield, MO 65803; www.suntouch.com