

Now includes our  
**LEAD FREE\***  
product offering



## Water Pressure Reducing Valves



watts.com

**WATTS**<sup>®</sup>

# Table of Contents

General Information .....	2 – 5
Water Pressure Reducing Valve Options Guide .....	5
Performance Curves .....	6 – 7
Water Pressure Reducing Valves .....	8
Series U5B/LFU5B – Water pressure reducing valves .....	8 – 9
Series 25AUB-Z3/LF25AUB-Z3 – Water pressure reducing valves .....	10 – 11
Series X65B/LFX65B – Water pressure reducing valves (½" – 2") .....	12 – 13
Series N55B-M1/LFN55B-M1 – Water pressure reducing valves (½" – 1") .....	14 – 15
Series N55B/LFN55B – Water pressure reducing valves (1¼" – 2") .....	16 – 17
Series N45B-M1/LF45B-M1 – Water pressure reducing valves (½" – 1") .....	18 – 19
Series N45B/LFN45B – Water pressure reducing valves (1¼" – 2") .....	20 – 21
Series N45B-EZ-M1 – Water pressure reducing valves (½" – 1") .....	22 – 23
Series N45B-EZ – Water pressure reducing valves (1¼" – 2") .....	24 – 25
Series 223, 223S and LF223, LF223S – Super capacity water pressure reducing valves .....	26 – 27
Series N223B, N223BS and LFN223B, LFN223BS – Super capacity water pressure reducing valves .....	28 – 29
Series N223F, N223FS/LFN223F, LFN223FS – Flanged super capacity water pressure reducing valves .....	30 – 31
Series 127W, F127W and LF127W – High capacity water pressure reducing valves .....	32 – 33
Series 2300 – Direct operated water pressure reducing valves .....	34
Series 115 – Water pressure reducing automatic control valves .....	35
Series N250, N250B – Iron body water pressure reducing valves with integral strainer .....	36
Series 26A, 263A and LF26A, LF263A – Small water pressure reducing valves .....	36
Series SS263AP – Stainless steel water pressure reducing valves .....	37
Series P60-M5 – Plastic miniature water pressure reducing valves .....	37
Series 560, H560 – Water pressure reducing valves .....	38
Series 123LP – Water pressure reducing valves .....	38
Series 215 – Super sensitive low pressure water pressure regulators .....	38
Model 276H300, IWTG – Water pressure test gauges .....	39
Series DPG-3, DPG-5 – Water pressure gauges .....	39
Jumper Kits .....	40

# General Information

## Ensuring Practical, Safe Working Water Pressures

Water pressure reducing valves have been in use as long ago as 1874, when Watts' regulators were employed to reduce the pressure of incoming water to industrial operations. Subsequently, they have been adapted for residential and commercial uses.

The most important and practical reason that water pressure reducing valves (WPRV's), also known as pressure regulators, are used is to protect against the effects of high water main pressures.

Municipal and private water supply companies use pumps and pumping stations

to boost water supply pressures in supply mains to be able to supply water for fire fighting, to overcome loss of pressure as the elevation increases in high rise buildings, and to maintain water supply in water towers and supply tanks. Pressure in water supply mains can exceed 200psi.

Most plumbing codes require water pressure reducing valves on domestic systems where the municipal water main's pressure exceeds 80psi. Higher pressures could rupture pipes, damage fixtures, and injure the people using them.

## Promoting Water Conservation

High water pressures waste water. Those concerned with conserving water, a vital and increasingly expensive resource, should be interested in reducing water consumption in order to reduce the cost of operating his or her home or business. Many municipalities today not only charge homeowners and businesses high rates for water consumption, but also charge consumers equally high rates for the dis-

posal of wastewater. Furthermore, reducing water consumption, reduces the excess energy required for heating additional hot water. Watts water pressure reducing valves have proven themselves over the years by promoting efficient water distribution and a longer life for the entire plumbing system, in addition to providing considerable savings in water and energy consumption.

## Why Do You Need a Watts Water Pressure Reducing Valve?

Common practice and analysis indicate that 50psi or less is sufficient inflow pressure for most home and commercial purposes. The higher the pressure the more of your water resources are wasted. Watts water pressure reducing valves will save you money, energy, system maintenance, and on the amount of wastewater returned to the environment (see Fig. 1).

- **Water Savings:** Twice as much water flows through a system at 150psi pressure than at 50psi. Much of this additional water is wasted.

- **Energy Savings:** If less water flows through the system, then less energy is needed to heat domestic hot water. Calculations show that a Watts water pressure reducing valve can save as much as 30% on domestic water heating costs.

- **Wastewater Savings:** When the community's wastewater treatment load is reduced, cost benefits accrue to both the environment and your bottom line.

**Many municipalities prorate sewer usage fees based upon the water meter reading.**

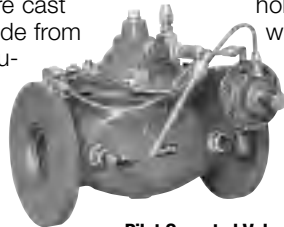

Fig. 1 – Faucet with 10 minutes running time

## What is a Water Pressure Reducing Valve?

There are two types of water pressure reducing valves, direct acting and pilot operated. Both use globe or angle style bodies. Valves used on smaller piping diameter units are cast from brass; larger piping diameter units are made from ductile iron. Direct acting valves, the more popular type of a water pressure reducing valves, consist of globe-type bodies with a spring-

loaded, heat-resistant diaphragm connected to the outlet of the valve that acts upon a spring. This spring holds a pre-set tension on the valve seat installed with a pressure equalizing mechanism for precise water pressure control.



Pilot Operated Valve



Direct Acting Valve

## How Does a Watts Direct Acting Water Pressure Reducing Valve Work?

Installed in series directly after the water meter in homes, commercial buildings, and manufacturing plants, a Watts water pressure reducing valve automatically reduces the pressure from the water supply main to a lower, more sensible pressure. Water entering the valve from municipal mains is constricted within the valve body and directed through the inner chamber controlled by an adjustable spring loaded diaphragm and disc. Even if the supply

water pressure fluctuates, the pressure reducing valve ensures a constant flow of water at a functional pressure, as long as the supply pressure does not drop below the valve's pre-set pressure.

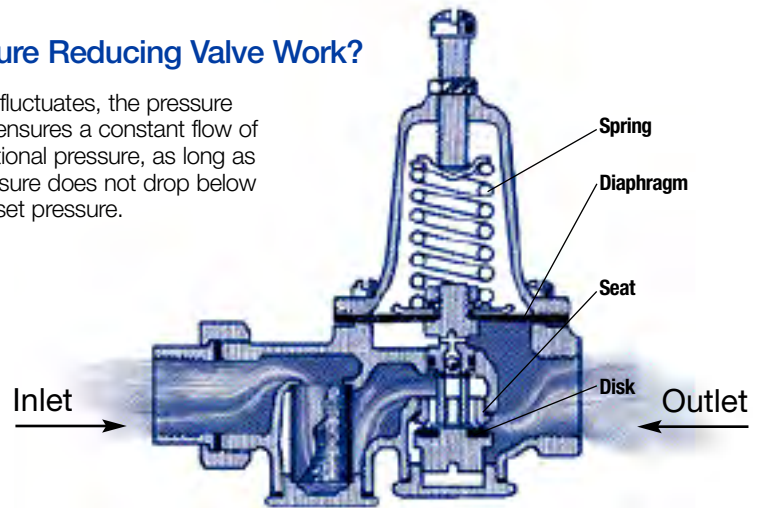

## Thermal Expansion Bypass Technology

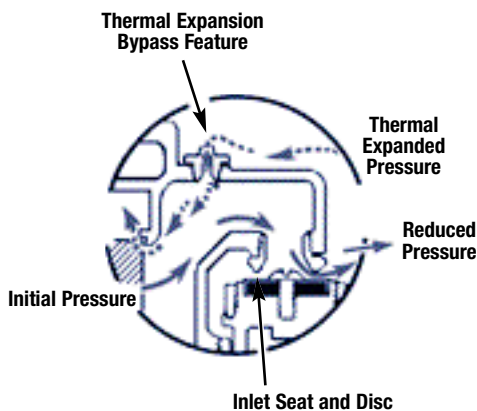

Fig. 2 – Watts Thermal Expansion Bypass feature

The installation of a water pressure reducing valve on the potable water distribution line creates a closed plumbing system, because water can no longer return to the supply main. A water heater installed in the system will cause the water in the heater to expand. This condition is known as thermal expansion. Thermal expansion of water can cause problems with the heater's temperature and pressure (T&P) relief valve. Watts Water Pressure Reducing Valves offer a patented, integral bypass check valve feature that eliminates frequent dripping of T&P relief valves caused by thermal expansion. Under normal operation, the check valve is held closed by the street main pressure. However, should thermal expansion pressure rise just 1psi higher than the supply pressure, the bypass opens, passing the expanded water back to the supply main. Thus, the expanding water is dissipated and the temperature and pressure relief valve is not affected.

The effectiveness of the bypass feature is limited to systems where the supply pressure is less than the pressure setting of the relief valve. The bypass model in no way replaces a water heater temperature and pressure (T&P) relief valve which is a necessary precaution to protect against other causes of excessive pressure. Even with a bypass feature installed, the installation of a backflow preventer or check valve on the water meter and/or high service pressure can result in the need to install a thermal expansion control device. Watts offers both thermal expansion tanks, as well as thermal expansion relief solutions. For more information on these products request literature *PG-ThermExpansion*.

**Note:** The bypass feature will not prevent the pressure relief valve from opening on the hot water supply system with pressures above 150psi.

## Sizing a Water Pressure Reducing Valve for Your Application

A properly sized valve prevents noisy operation or premature valve failure. Over sizing water pressure reducing valves can lead to problems such as wire draw under low flow conditions. In general, the minimum flow through a water pressure reducing valve should be 10% to 15% of the maximum flow rate desired in the

system. Also, water pressure reducing valves should be selected based on the flow and pressure ranges listed in the literature, not the size of the pipe to which they will be attached. You should select a regulator where operating pressures fall within the middle of its rated range.

For example, if you want to create a working pressure of 50psi within a building with a flow rate of 35 to 40 gpm, and a reduced pressure fall-off of 20psi, working with a supply water pressure of 150psi, using Table I, on page 4 (example 1), you would choose to use a 1" Watts 25AUB-Z3.

## Choosing the Correct Installation Configuration

Watts Water Pressure Reducing Valves can increase your water system's performance, reduce operating costs, and ensure a longer life for other plumbing fixtures. Most simple pressure reducing applications require the installation of a single regulator. However, there are appli-

cations that require the use of more than one unit installed in a specific system configuration.

When there is wide variation in pressure between the municipal main's inflow pressure and the functional pressure needed within the building, or when the main's

pressure exceeds 200psi, you should consider using a two-stage, serial reduction configuration.

When you want to maintain a continuous supply of water at reduced pressures, you should consider a parallel installation.

## Two-Stage Serial Reduction Configuration

The two-stage serial reduction approach uses two valves in series to reduce or eliminate extreme variations between the water main's inflow pressure and the desired, final reduced pressure. Two-stage reduction is recommended when initial pressures are 200psi or greater, or when the desired pressure reduction ratio is greater than 4:1, e.g., from 200psi to 50psi, or where the inflow pressure fluctuates greatly.

The advantage of two-stage serial reduction is that neither valve is subjected to extreme pressure differential, thus prolonging valve life and delivering more precise pressure regulation.

Selecting the proper valves and pressure settings is straightforward. For example in Fig. 3, the first regulator in series reduces the main's pressure of 250psi to 150psi, and the second regulator reduces the pressure from 150psi to approximately 50psi. A similar ratio should be used no matter the initial inflow pressure.

Valve sizes and capacities should be selected from the capacity table (see Table I) below. Remember, each valve's flow capacity should exceed the total flow requirement of the system. For example, assume that the desired system capacity is 80 gallons per minute (gpm). In reviewing Table I,

we find that a 2" Series U5B-Z3 valve and a 1½" Series 223S valve exceed the 80 gpm capacity at either a 10psi or 15psi fall-off pressure (example 2). You should then select the appropriate valves based on relative product cost and performance at lower fall-off pressures.

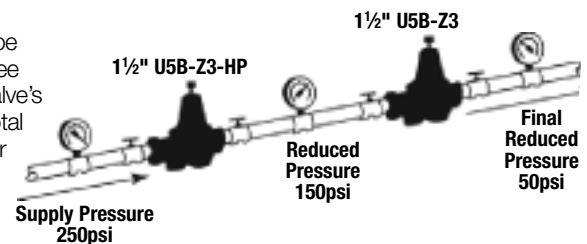

Fig. 3 – Two-stage serial reduction configuration

Table I

### Summary of Capacities of Watts Water Pressure Reducing Valves

Table shows capacity in gallons per minute based on various reduced pressure fall-off.

□ = Example 1    ○ = Example 2

FALL-OFF PRESSURE	CAPACITY (GALLONS PER MINUTE)																		
	U5B-Z3						25AUB-Z3						223 - 223S						
	½"	¾"	1"	1¼"	1½"	2"	½"	¾"	1"	1¼"	1½"	2"	½"	¾"	1"	1¼"	1½"	2"	2½"
5psi	5	6	7	9	12	30	2	3	5	3	5	15	8	10	12	16	37	50	60
10psi	10	13	20	25	32	60	5	7	10	10	10	28	16	20	29	46	80	100	105
15psi	12	21	30	40	52	84	10	15	22	26	33	55	20	29	40	70	107	136	143
20psi	17	27	40	50	64	100	16	25	38	52	60	85	23	36	50	88	132	162	170

**Please Note:** For average installations and applications, the capacities shown at 20psi fall-off are recommended since statistics show that typical demands are well within the total sized capacity of the system. Capacities at 15, 10, and 5psi are offered for comparison and where a lesser fall-off is needed or required for maximum performance, or a specific application.

## Parallel Installation

The parallel installation makes use of two or more smaller size water pressure reducing valves serving a large size supply pipe main (see Table III on page 5 for reference). This approach should be used wherever there is a wide variation of reduced pressure requirements such as an apartment building where demand could be .5 gpm at 1am and 100 gpm at 6am and where you must maintain a continuous water supply. Parallel installations also offer the advantage of providing increased capacity where needed beyond that provided by a single valve. In addition, the parallel configuration improves valve performance for wide variable demands and permits servicing of an individual valve

without shutting down water flow to the building completely, thus avoiding costly shutdowns. (The extra piping is not a factor inasmuch as the secondary valve uses the "piping bypass" line that is always recommended in the installation of larger size regulators).

For a two-valve installation as shown, the total capacity of the valves should equal or exceed the capacity required by the system. One valve should be set at 10psi higher delivery pressure than the other. For example, assume that the system is piped for 265 gpm and the delivery

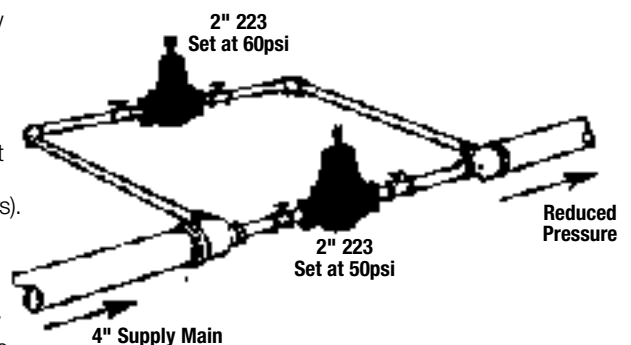

Fig. 4 – Parallel Installation

**Note:** The lower set valve is recommended to be located on the main run with the higher set valve located on the saddle for easier maintenance of this 100% used valve.

Table II

### Summary of Capacities of Watts Water Pressure Reducing Valves

Table shows capacity in gallons per minute based on various reduced pressure fall-off.

◇ = Example 3    ○ = Example 4

FALL-OFF PRESSURE	CAPACITY (GALLONS PER MINUTE)											
	223 - 223S							N223B		N223F	127W	
	½"	¾"	1"	1¼"	1½"	2"	2½"	2½"	3"	3"	3"	4"
5psi	8	10	12	16	37	50	60	60	85	70	75	80
10psi	16	20	29	46	80	100	105	130	180	120	130	140
15psi	20	29	40	70	107	136	143	200	280	160	180	230
20psi	23	36	50	88	132	162	170	285	375	210	250	300

pressure required is 50psi. One valve should be set at 50psi, with the other valve set 10psi higher at 60psi. Thus, when low volume is required, the higher set valve operates alone. When a larger volume is needed, both valves open, delivering full line capacity.

Now, select from Table II, on page 4, two valves whose total capacity equals or exceeds 265gpm. Referring to the Series 223 in Table II (example 3), note that the 2" size offers a capacity of 136gpm, at a 15psi fall-off (totaling 272gpm). Or the 2½" size, Series 223 has a capacity of 143gpm at a 15psi fall-off (totaling 286gpm). Thus, the 2" size Series 223 would appear to be adequate since excellent flow would be provided between 15psi and 20psi fall-off, not to mention lesser fall-offs for typical lower demands.

### Parallel Installation of Same Size Regulators

Use Table III, shown below, as a convenient reference for choosing the various combinations of regulators of the same size whose equivalent capacity matches that of a larger valve or pipeline capacity. Although Table II shows only two-valve combinations of the

same size, three valves can also be used. It is only necessary that the sum of the valves' capacities equal the system requirements.

For example, as shown in Table II, a system requiring 275gpm at 20psi fall-off pressure could use two of the 3" N223F valves or two 2½" 223's. The final selection would be based on the comparative potential capacity performance of 20psi fall-off pressure.

We recommend restricting installations to two valves for most applications to avoid excessive pressure drop and to assure more precise control of reduced pressure. The number of regulators used should be determined by the engineer's judgment, based on operating conditions for a specific installation.

### Parallel Installation of Different Size Regulators

Another type of parallel installation is one using a two-valve combination of different sizes. This would be practical on larger commercial or institutional installations where supply lines are 2" and larger and where there are frequent periods of low volume demand. In such cases, the smaller

valve would have the 10psi higher delivery pressure and thus operate alone to satisfy small demands such as for the flushing of urinals or for supply to drinking fountains. When a larger volume is required, the main regulator would open to satisfy the system demand, for example for an apartment building requiring 275gpm. In this case, selection could be a 4" 127W and a 1" 223 as shown in Table II, Example 4.

**Table IV** – Shows the average rate of water flow in pipe lines which is used quite generally in supply system design. Watts water pressure reducing valves are designed to equal or exceed these capacities.

PIPE SIZE	GPM FLOW
½"	10
¾"	16
1"	25
1¼"	41
1½"	55
2"	84
2½"	115
3"	165
4"	265
6"	530

**Table III**

Valve	NUMBER OF SMALLER SIZE VALVES OF SAME SIZE TO MEET REQUIRED CAPACITY AT 15psi FALL-OFF PRESSURE																								
	Capacity Required for System (gpm)																								
	30	40	50	60	70	80	90	100	110	120	130	140	150	160	175	200	225	250	275	300	400	450	500	550	600
Series 25AUB-Z3	2-¾"	2-1"	2-1¼"	2-1½"	2-2"	2-2"	2-2"	2-2"	2-2"																
Series USB-Z3	2-¾"	2-¾"	2-1"	2-1"	2-¼"	2-¼"	2-1½"	2-1½"	2-2"	2-2"	2-2"	2-2"	2-2"	2-2"											
Series 223	2-½"	2-½"	2-¾"	2-1"	2-1"	2-1"	2-1¼"	2-1¼"	2-1¼"	2-1¼"	2-1¼"	2-1¼"	2-1½"	2-1½"	2-1½"	2-1½"	2-2"	2-2"	2-2½"						
Series N223B																					2-2½"	2-2½"	2-2½"	2-3"	2-3"
Series N223F																					2-3"				
Series 127W																					2-3"	2-4"	2-4"		

## Lead Free\* Construction

Lead Free\* construction (designated with an "LF" prefix) is now available as an option in many of our most popular Water Pressure Reducing Valve Series

\*The wetted surface of this product contacted by consumable water contains less than one quarter of one percent (0.25%) of lead by weight.

## End Connections

To facilitate installation and servicing of the regulator, Watts offers a variety of end fitting configurations, which include union fittings (female threaded, solder, CPVC, PEX, and Quick-Connect end connections), flanged valves, water meter threads and special lay lengths for water meter installations. Please refer to the valve model for specific availability of end connection options.

# Performance Curves

To match the valve characteristics to system requirements Watts has provided performance curves for each type and size of valve giving the capacities of each with reduced pressure fall-offs up to 25psi.

By the use of these charts, the most suitable and economical valve can be selected to satisfy the job requirements.

The charts or curves for all types are plotted on a simple basis of rate of flow plotted against the reduced pressure fall-off.

In the left hand column, the reduced pressure fall-off is listed up to 25psi. Along the bottom, is listed capacity in terms of gallons per minute flow.

In the reduced pressure fall-off column, the "0" represents the reduced pressure setting of the valve set point when there is no flow (reduced lock-up pressure). It can be any setting within the adjustment range of the valve. The figures below "0" show the pressure fall-off or change the set pressure that results in the flow shown by the curves of the various sizes of valves.

With Watts water pressure reducing valves, the difference between the initial and reduced lock-up (no-flow) pressures has a minor effect upon the valve capacity except when it is less than 50psi. When this difference is less than 50psi, the capacity of the valve is reduced and some minor compensation must be made in the sizing procedure. Therefore, either deduct 20% from capacity shown or add 20% to capacity required.

Where more than one type has adequate capacity, the selection should consider the advantages of the one that would permit smaller pipe sizing and evaluate the relative costs of each.

In solving capacity sizing problems, it is suggested that Chart No. 1 is to be used for a trial solution and the results then compared with other types for final evaluation of the selection.

The following examples are prepared to enable a clear understanding of the use of the charts in selecting valves for specific applications or determining valve capacities under specific pressure conditions.

Refer to specific charts on each page of the guide or engineering sheets.

**EXAMPLE: Chart No. 1**

- Initial supply pressure: 100psi
- Reduced no-flow (set) pressure: 50psi
- Demand: 20 gallons per minute
- Allowable reduced pressure fall-off: 15psi

On Chart No. 1, locate 20 gallons per minute along the bottom line and move up until it intersects a curve line. In this case, it intersects the 3/4" size at approximately the 14psi reduced pressure fall-off line. Thus, the 3/4" size provides the required capacity at less than a 15psi fall-off and therefore, will give excellent reduced flow pressure service.

In this procedure, also note a 1/2" Model 223 in Chart No. 3 will meet this capacity at a 15psi fall-off.

**EXAMPLE: Chart No. 1**

- Find the maximum capacity of a 1" sized valve.
- Find the 1" size curve and the intersection with the 20psi pressure fall-off line. Moving down from this intersection, the a flow of 40 is found.
- The valves maximum capacity is 40 gallons per minute.

**Chart No. 1 – Series U5B-Z3**

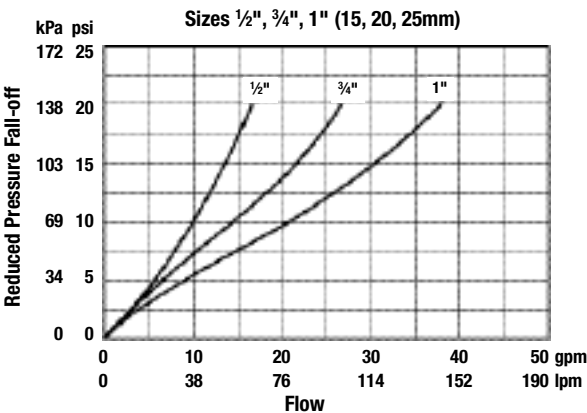

**Chart No. 1A – Series U5B-Z3**

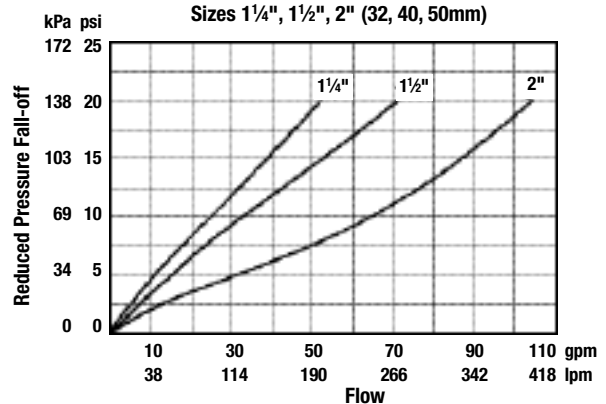

**Chart No. 2 – Series 25AUB-Z3**

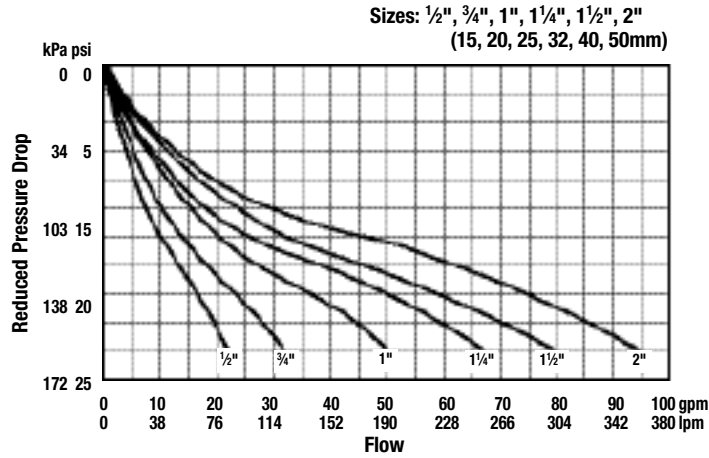

**Chart No. 2A – Series N223B**

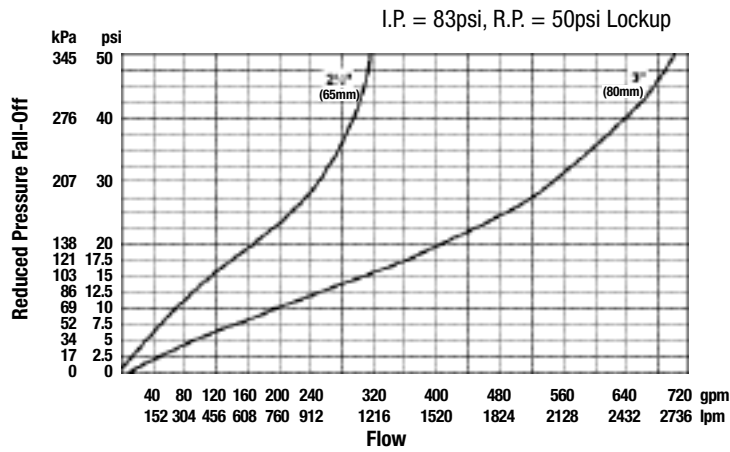

**Chart No. 3 – Series 223**

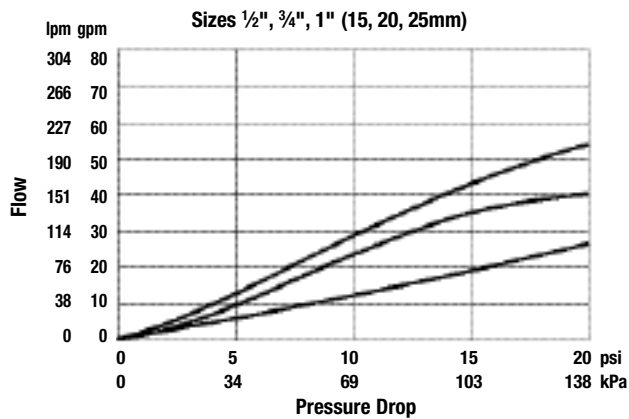

**Chart No. 3A – Series 223**

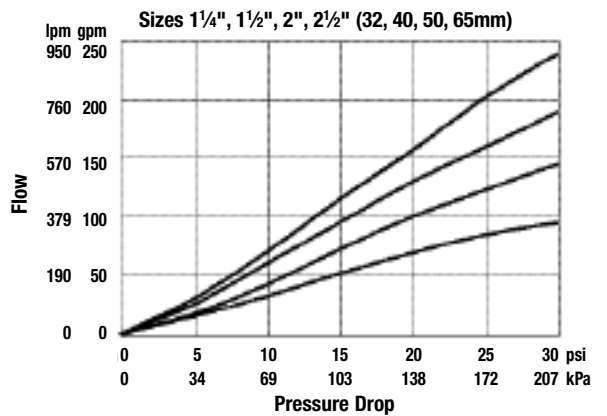

# Series U5B and LFU5B

## Water Pressure Reducing Valves

Sizes: 1/2" – 2" (15 – 50mm)

Series U5B and LFU5B Water Pressure Reducing Valves are designed to reduce incoming water pressure to a sensible level to protect plumbing system components and reduce water consumption. Lead Free\* models are available with Lead Free\* brass construction to comply with Lead Free\* installation requirements. This series is suitable for water supply pressures up to 300psi (21 bar) and may be adjusted from 25 – 75psi (172 – 517 kPa). The standard setting is 50psi (345 kPa). All parts are quickly and easily serviceable without removing the valve from the line. The U5B-Z3's and LFU5B-Z3's standard bypass feature permits the flow of water back through the valve into the main when pressures, due to thermal expansion on the outlet side of the valve, exceed the pressure in the main.

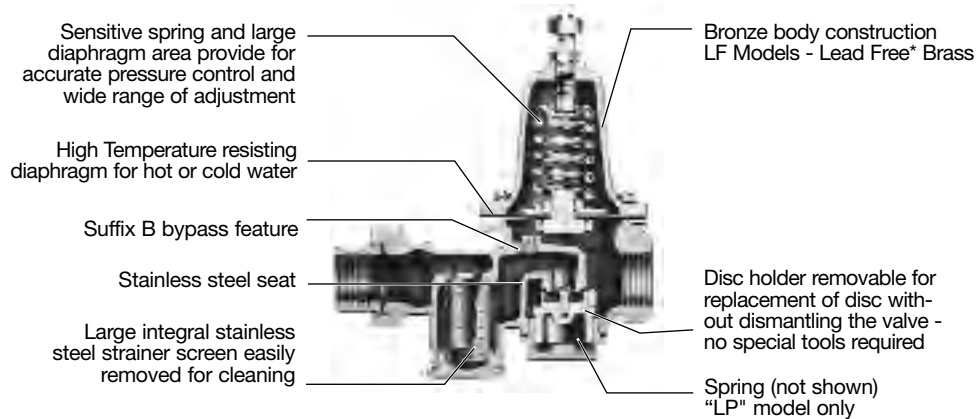

### Features

- Lead Free\* models available
- Standard construction includes Z3 sealed epoxy coated spring cage and corrosion resistant adjusting and cage screws for accessible outdoors or pit installations
- Integral stainless steel strainer
- Replaceable seat module
- Bronze body construction
- Lead Free\* models are constructed with Lead Free\* brass body construction
- Serviceable in line
- Bypass feature controls thermal expansion pressure (U5B-Z3 and LFU5B-Z3)\*
- High temperature resistant reinforced diaphragm for hot water

### Models

U5B-Z3	NPT threaded female union inlet x NPT female outlet w/built in thermal expansion bypass
LFU5B-Z3	
U5B-S-Z3	Solder union inlet x NPT female outlet w/built in thermal expansion bypass
LFU5B-S-Z3	
5M3-Z6	Water meter threaded connections and 7 1/2" (190mm) lay length for new or existing meter box installations. For 5/8" (16mm), 5/8" x 3/4" (16 x 20mm) or 3/4" (20mm) meter setters or reletters
U5B-QC-Z3	Quick-Connect Single-Union-Inlet end
LFU5B-QC-Z3	

### Options

#### add Suffix:

- G Gauge tapping 1/8" (3mm)
- GG Gauge tapping and 160psi (11 bar) gauge
- HP High pressure range 75 – 100psi (5.3 – 6.9 bar)
- LP Low pressure range 10 – 35psi (69 – 241 kPa)

#### add Prefix:

- LF Lead Free\* construction

\*The wetted surface of this product contacted by consumable water contains less than one quarter of one percent (0.25%) of lead by weight.

**Note:** The bypass feature will not prevent the pressure relief valve from opening on the hot water supply system with pressures above 150psi.

## Pressure – Temperature

Temperature Range: 33°F – 160°F  
(0.5°C – 71°C)

Maximum Working Pressure: 300psi  
(21 bar)

Adjustable Reduced Pressure Range:  
25 – 75psi (172 – 517 kPa)

Standard Reduced Pressure Setting:  
50psi (345 kPa)



Meets requirements of ASSE Standard 1003; (ANSI A112.26.2); CSA Standard B356; Southern Standard Plumbing Code and listed by IAPMO.

## Capacity

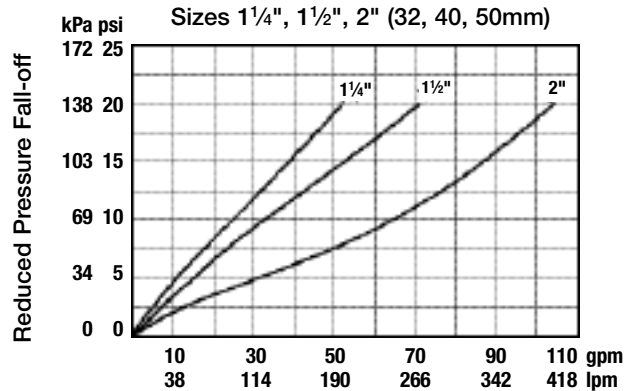
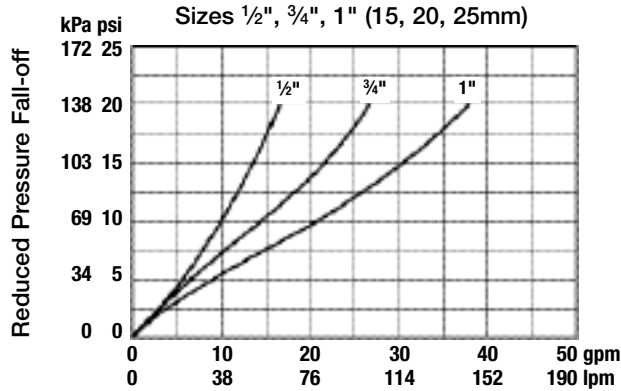

## Dimensions — Weights

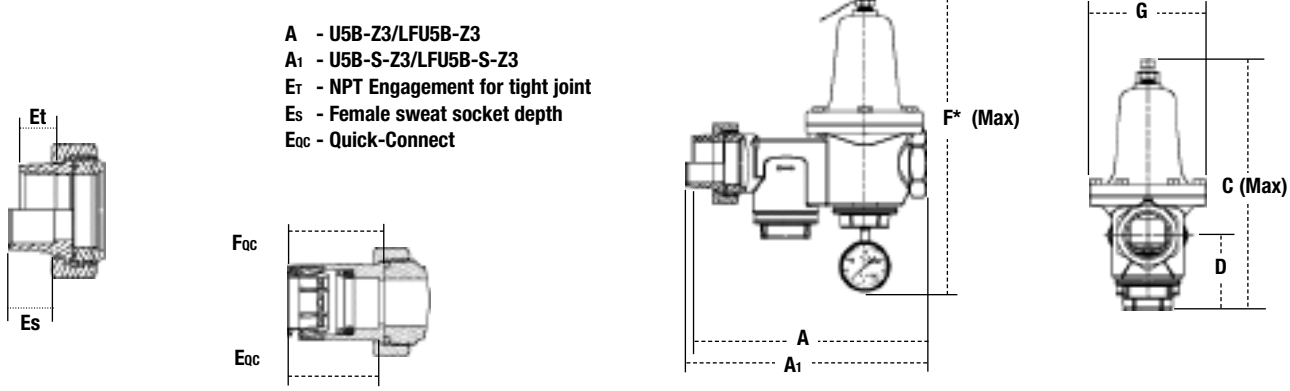

SIZE (DN)	DIMENSIONS (APPROX.)											WEIGHT					
	A		A <sub>1</sub>		C		D		G		Et	Es	Eoc	Foc	F †		lbs.
in. mm	in. mm	in. mm	in. mm	in. mm	in. mm	in. mm	in. mm	in. mm	in. mm	in. mm	in. mm	in. mm	in. mm	in. mm	in. mm		
1/2 15	5 5/8 142.8	5 1/2 139.7	5 7/8 149.2	1 5/8 41.2	3 1/16 77.7	7/16 11.1	1/2 12.7	1 7/16 36	1 1/2 38	10 1/4 260.3	4	1.8					
3/4 20	6 3/16 157.1	6 1/4 158.7	6 7/8 174.6	1 7/8 47.6	3 1/2 88.9	1/2 12.7	3/4 19	1 9/16 40	1 11/16 42	11 1/2 292.1	5	2.3					
1 25	6 5/8 168.2	6 3/4 171.4	7 3/8 187.3	2 50.8	4 101.6	9/16 14.2	7/8 22.2	1 11/16 43	1 3/4 45	12 1/8 307.9	6	2.7					
1 1/4 32	7 15/16 190.5	7 11/16 195.2	8 3/8 212.7	2 1/4 57.1	4 1/2 113.3	5/8 15.8	1 25.4	-	-	13 3/8 339.7	9.4	4.3					
1 1/2 40	9 7/16 239.7	9 3/4 247.6	9 3/8 238.1	2 7/8 73	4 3/4 120.6	5/8 15.8	1 1/8 28.5	-	-	15 381.0	14.4	6.5					
2 50	10 7/8 276.2	11 1/2 292.1	12 1/4 311.1	3 1/4 82.5	6 152.4	5/8 15.8	1 3/8 34.9	-	-	18 1/4 463.5	23	10.4					

† Dimension includes optional gauge

# Series 25AUB-Z3 and LF25AUB-Z3

## Water Pressure Reducing Valves

Sizes: 1/2" – 2" (15 – 50mm)

Series 25AUB-Z3 and LF25AUB-Z3 Water Pressure Reducing Valves are designed to reduce incoming water pressure to a sensible level to protect plumbing system components and reduce water consumption. This series is suitable for water supply pressures up to 300psi (21 bar) and may be adjusted from 25 – 75psi (172 – 517 kPa). The LF25AUB-Z3 features Lead Free\* construction to comply with Lead Free\* installation requirements. The standard setting is 50psi (345 kPa). All parts are quickly and easily serviceable without removing the valve from the line. The standard bypass feature permits the flow of water back through the valve into the main when pressures, due to thermal expansion on the outlet side of the valve, exceed the pressure in the main.

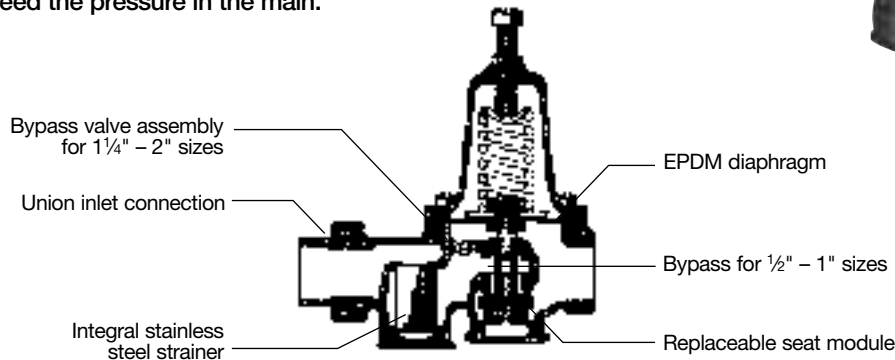

### Features

- Standard construction includes Z3 sealed epoxy coated spring cage and corrosion resistant adjusting and cage screws for accessible outdoors or pit installations
- Union inlet connection
- Integral stainless steel strainer
- Replaceable seat module
- Bronze body construction
- Lead Free\* models with Lead Free\* brass body construction
- Serviceable in line
- Bypass feature controls thermal expansion pressure\*
- High temperature resistant reinforced diaphragm for hot water

### Models

25AUB-Z3	NPT threaded female union inlet x NPT female outlet
LF25AUB-Z3	NPT female outlet
25AUB-S-Z3	Solder union inlet x NPT female outlet
LF25AUB-S-Z3	NPT female outlet
25AUB-DU-Z3	Double Union – NPT threaded union female inlet and outlet
LF25AUB-DU-Z3	NPT threaded union female inlet and outlet
25AUB-S-DU-Z3	Double Union – Solder union inlet and outlet
LF25AUB-S-DU-Z3	Double Union – Solder union inlet and outlet
25AUB-DU-THDxPEX-Z3	Double Union – NPT threaded female inlet and PEX union outlet
LF25AUB-DU-THDxPEX-Z3	Double Union – NPT threaded female inlet and PEX union outlet
25AUB-DU-CPVC-Z3	Double Union – CPVC union inlet and outlet
LF25AUB-DU-CPVC-Z3	Double Union – CPVC union inlet and outlet
25AUB-DU-LF-Z3	Double Union body less union fittings
25AUB-QC-Z3	Single Union Quick-Connect inlet
LF25AUB-QC-Z3	Connect inlet
25AUB-DU-QC-Z3	Double Union Quick-Connect inlet and outlet
LF25AUB-DU-QC-Z3	Double Union Quick-Connect inlet and outlet

### Options

#### add Suffix:

- G 1/4" (3mm) Gauge tapping on 1/2"-3/4" (20, 25mm) all other sizes 1/8" (3mm)
- GG Gauge tapping and 160psi (11 bar) gauge
- HP High pressure range 75 – 125psi (5.27 – 8.8 bar)
- LP Low pressure range 10 – 35psi (69 – 241 kPa).
- Z7 400psi (27.6 bar) initial pressure, 1/2" (20mm) models only

#### add Prefix:

- LF Lead Free\* construction

### Pressure – Temperature

Temperature Range: 33°F – 160°F (0.5°C – 71°C)  
 Maximum Working Pressure: 300psi (21 bar)  
 Adjustable Reduced Pressure Range: 25 – 75psi (172 – 517 kPa)  
 Standard Reduced Pressure Setting: 50psi (345 kPa)

### Standards



Meets requirements of ASSE Standard 1003; (ANSI A112.26.2: CSA Standard B356; Southern Standard Plumbing Code and listed by IAPMO. Military Standard MIL-V-18146B Type I.

\*The wetted surface of this product contacted by consumable water contains less than one quarter of one percent (0.25%) of lead by weight.

**Note:** The bypass feature will not prevent the pressure relief valve from opening on the hot water supply system with pressures above 150psi.

## Capacity

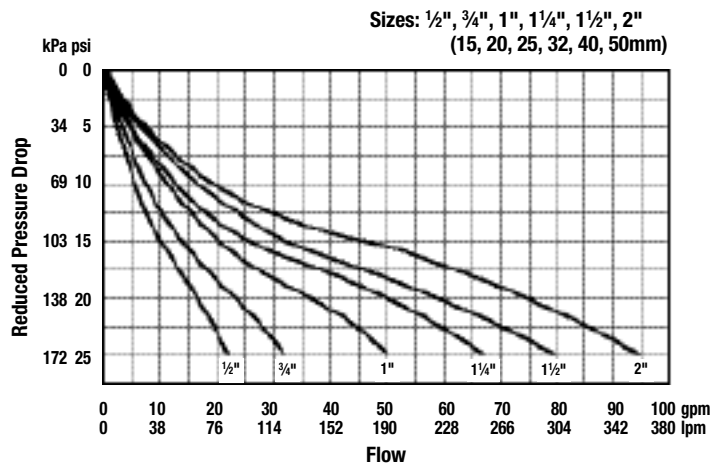

## Dimensions — Weights

- A - 25AUB-Z3/LF25AUB-Z3
- A<sub>1</sub> - 25AUB-S-Z3/LF25AUB-S-Z3
- A<sub>2</sub> - 25AUB-DU-LF-Z3
- B - 25AUB-DU-Z3/LF25AUB-DU-Z3
- B<sub>1</sub> - 25AUB-S-DU-Z3/LF25AUB-S-DU-Z3
- B<sub>2</sub> - 25AUB-DU-THDxPEX-Z3/LF25AUB-DU-THDxPEX-Z3
- E<sub>T</sub> - NPT Engagement for tight joint
- E<sub>S</sub> - Female sweat socket depth
- E<sub>P</sub> - PEX end connection
- E<sub>QC</sub> - Quick-Connect union

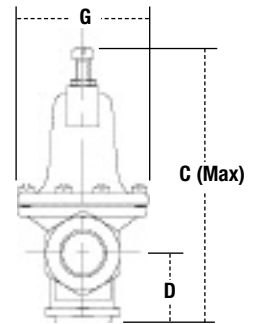
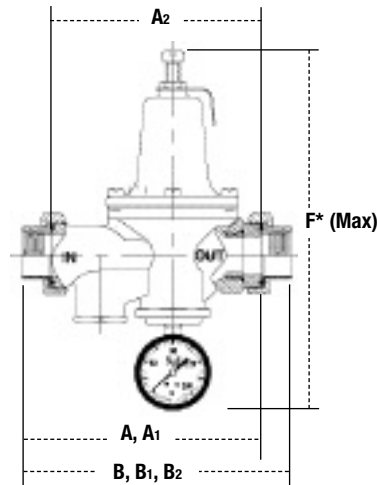
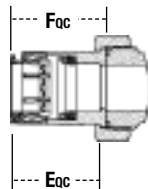
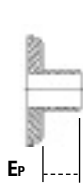
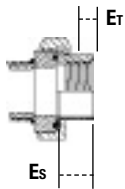

SIZE (DN)		DIMENSIONS (APPROX.)													
in.	mm	A		A <sub>1</sub>		A <sub>2</sub>		B		B <sub>1</sub>		B <sub>2</sub>		C	
		in.	mm	in.	mm	in.	mm	in.	mm	in.	mm	in.	mm	in.	mm
1/2	15	5 3/8	137	5 9/16	135	5 3/16	132	6 7/16	164	6 3/8	162	-	-	7	178
3/4	20	5 5/16	135	5 1/2	140	5 1/4	133	6 1/2	165	6 7/8	175	6 3/4	171	7	178
1	25	6	152	6 1/4	159	5 7/8	149	7 3/8	187	7 13/16	198	7 1 1/16	195	8	203
1 1/4	32	8 3/4	222	8 15/16	227	8 1/4	210	10 3/4	273	11	279	-	-	9	229
1 1/2	40	8 3/4	222	9	229	8 1/4	210	10 3/4	273	11 3/16	284	-	-	9 1/2	241
2	50	9 1/4	235	10	254	8 3/4	222	11 5/16	287	12 1 1/16	322	-	-	11 1/4	286

DIMENSIONS (APPROX.)										WEIGHT							
D		F †		G		E <sub>T</sub>		E <sub>S</sub>		E <sub>P</sub>		E <sub>QC</sub>		F <sub>QC</sub>		lbs.	kg.
in.	mm	in.	mm	in.	mm	in.	mm	in.	mm	in.	mm	in.	mm	in.	mm		
1 1/2	38	9 7/16	240	3 1/8	79	1/2	13	1/2	13	-	-	1 7/8	36	1 1/2	38	3.5	1.6
1 1/2	38	9 7/16	240	3 1/8	79	1/2	13	3/4	19	5/8	16	1 1/16	40	1 11/16	42	3.5	1.6
1 3/4	44	10 7/16	266	3 5/8	92	5/8	16	1 5/16	23	1 3/16	21	1 11/16	43	1 3/4	45	6.5	3.0
2 1/8	54	11 7/16	291	3 5/8	92	5/8	16	1	25	-	-	-	-	-	-	10	4.5
2 3/8	60	11 15/16	304	4 1/16	103	5/8	16	1 1/16	28	-	-	-	-	-	-	10	4.5
3 1/4	83	13 1 1/16	348	4 3/4	121	5/8	16	1 5/16	34	-	-	-	-	-	-	15	6.8

† Dimension includes optional gauge

# Series X65B and LFX65B

## Water Pressure Reducing Valves†

Sizes: 1/2"– 2" (15 – 50mm)

Series X65B and LFX65B Water Pressure Reducing Valves are designed to reduce incoming water pressure to a sensible level to protect plumbing system components and reduce water consumption. The X65B and LFX65B are a cartridge style regulator and is orderable three ways: As a complete, ready-to-install regulator, or as a separate Rough-in Kit consisting of a bronze body with integral strainer, or as a separate Cartridge Assembly. The LFX65B feature a Lead Free\* brass body to comply with Lead Free\* installation requirements. The X65B and LFX65B deliver superior flow performance with low fall off pressure while reducing flow noise with its engineered seat design. The X65B and LFX65B are a 100 percent balanced valve, as inlet pressures fluctuate, reduced pressure does not. The X65B and LFX65B incorporate control valve style stem and disc guidance for accuracy and longevity. They are available with interchangeable union tailpiece kits in standard-sized solder and threaded tailpieces for Quick-Connect, PEX and CPVC options. The X65B and LFX65B Cartridge Assemblies are available in standard pressure range of 20 - 80psi (138 - 552 kPa), preset at the factory to 50psi (345 kPa) or high-pressure range (HP) of 50 - 150psi (345 to 1034 kPa) preset at the factory to 100psi (6.9 bar). The standard bypass feature\*\* permits the flow of water back through the valve into the main when pressures, due to thermal expansion on the outlet side of the valve, exceed the pressure in the main supply.

### Features

- Lead Free\* models are available
- Cartridge Style valve enables quick and easy installation or service in-line
- Greater flow performance with lower fall off pressure for consistent operation
- Seat design reduces flow noise
- 100% balanced valve, unique to Watts, provides reliable flow performance
- Full size range available rated to 400psi to meet your commercial and residential applications
- Cartridge Assemblies available in standard and high-pressure (HP) models
- Bypass feature in Cartridge Assembly controls thermal expansion pressure\*\*
- Standard construction includes sealed spring cage and corrosion resistant adjusting and cage screws for accessible outdoor or pit installations
- High performance thermoplastic integral seat cartridge
- Union inlet connection and tailpiece kits for solder, Quick-Connect, PEX, CPVC and threaded to meet your commercial and residential applications.
- High temperature resistant reinforced diaphragm for hot water

†A water saving test program concluded that reducing the supply pressure from 80 to 50psi (551-345 kPa) resulted in a water savings of 30%.

### Models

X65B	NPT threaded female inlet x NPT female outlet
LFX65B	NPT threaded female inlet x NPT female outlet
X65BU	NPT threaded union inlet x NPT female outlet
LFX65BU	NPT threaded union inlet x NPT female outlet
X65BUS	Solder union inlet x NPT female outlet
LFX65BUS	Solder union inlet x NPT female outlet
X65BDU	Double Union – NPT threaded union female inlet and outlet
LFX65BDU	Double Union – NPT threaded union female inlet and outlet
X65BDUS	Double Union – Solder union inlet and outlet
LFX65BDUS	Double Union – Solder union inlet and outlet
X65BU-QC	Single Union – Quick-Connect union inlet x NPT female outlet†
LFX65BU-QC	Single Union – Quick-Connect union inlet x NPT female outlet†
X65BDU-QC	Double Union – Quick-Connect union inlet and outlet†
LFX65BDU-QC	Double Union – Quick-Connect union inlet and outlet†
X65BDU-CPVC	Double Union - CPVC union inlet x CPVC union outlet††
LFX65BDU-CPVC	Double Union - CPVC union inlet x CPVC union outlet††
X65BDU-PEX	Double Union - PEX union inlet x PEX union outlet†
LFX65BDU-PEX	Double Union - PEX union inlet x PEX union outlet†
X65B-HP	High Pressure – NPT threaded female inlet x NPT female outlet
LFX65B-HP	High Pressure – NPT threaded female inlet x NPT female outlet

†For sizes 1/2", 3/4", 1" (15, 20, 25mm) only

††For sizes 3/4", 1" (20, 25mm) only

### Materials

Body:	Bronze LF Model constructed from Lead Free* brass
Seat:	Thermoplastic cartridge
Integral Strainer:	Stainless steel
Diaphragm:	Reinforced EPDM
Valve Disc:	EPDM

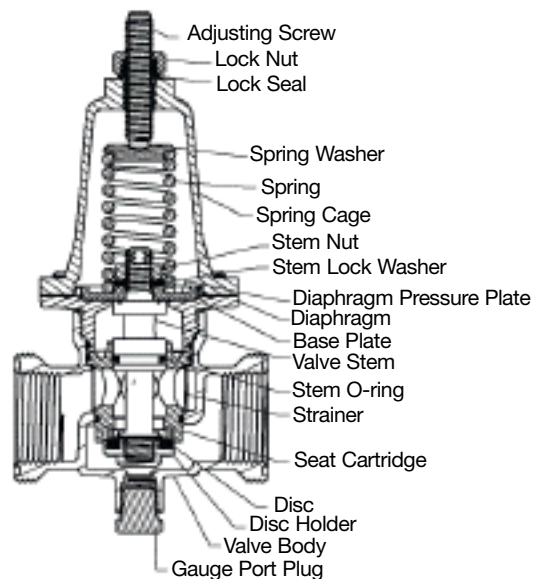

### Pressure – Temperature

Temperature Range: 33°F – 180°F (0.5°C – 82°C)

Maximum Working Pressure: 400psi (27.6 bar)

Adjustable Reduced Pressure Range: 20 – 80psi (138 – 552 kPa)

Standard Reduced Pressure Setting: 50psi (345 kPa)

HP Reduced Pressure Range: 50 – 150psi (345 – 1034 kPa)

HP Reduced Pressure Setting: 100psi (6.9 bar)

### Options

#### add Suffix:

G Gauge tapping, 1/4" (8mm)

GG Gauge tapping and 160psi (11.0 bar) gauge

HP High pressure range 50 – 150psi (3.4 – 10.3 bar)

#### add Prefix:

LF Lead Free\* construction

\*The wetted surface of this product contacted by consumable water contains less than one quarter of one percent (0.25%) of lead by weight.

Note: \*\*The bypass feature will not prevent the pressure relief valve from opening on the hot water supply system with pressures above 150psi.

## Standards



Certified to ASSE Standard 1003, and listed by ASSE and IAMPO.

## Capacity

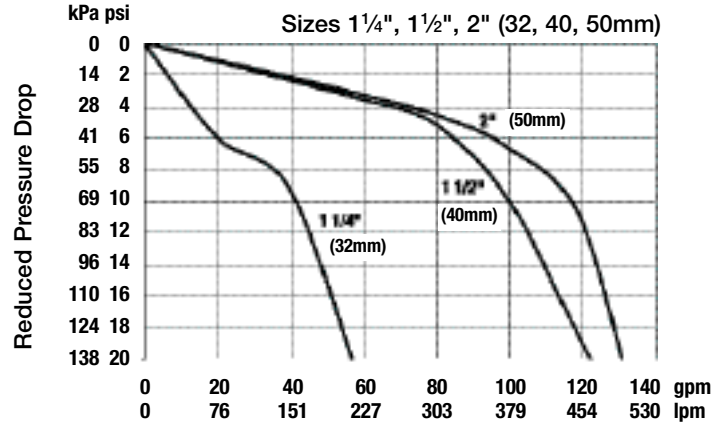
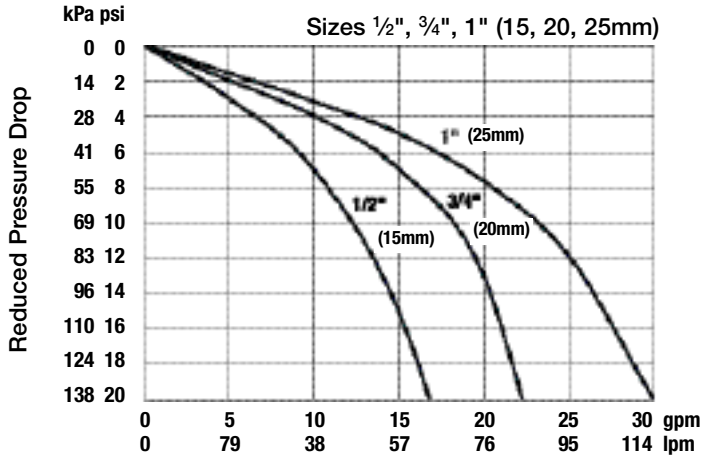

## Dimensions — Weights

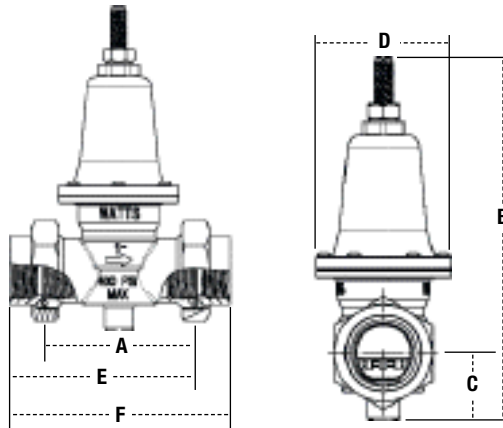

SIZE (DN)		DIMENSIONS										WEIGHTS													
in.	mm	A		B (MAX) STD		B (MAX) HP		C		D (DIA)		E (Threaded)		E (Sweat)		E (QC)		F (Threaded)		F (Sweat)		F (QC)		lbs.	kgs.
		in.	mm	in.	mm	in.	mm	in.	mm	in.	mm	in.	mm	in.	mm	in.	mm	in.	mm	in.	mm	in.	mm		
1/2	15	3	76.7	5 7/16	137.7	6 1 1/16	169.9	1 5/16	32.8	2 7/16	61.2	3 1 1/16	93.0	3 5/8	91.9	4 1/2	115	4 5/16	109.2	4 1/4	107.2	6	153	1.43	0.65
3/4	20	3 1/8	79.8	5 7/16	137.7	6 1 1/16	169.9	1 5/16	32.8	2 7/16	61.2	3 3/4	96.0	4	101.1	4 13/16	122	4 7/16	112.3	4 13/16	122.4	6 1/2	165	1.52	0.69
1	25	3 9/16	90.4	6 3/16	157.2	7 1/4	199.9	1 3/8	34.5	2 3/4	70.6	4 15/16	110.2	4 9/16	116.1	5 5/16	135	5 1/8	130.0	5 9/16	141.7	7 1/16	179	2.22	1.01
1 1/4	32	4 5/16	110.2	6 15/16	176.0	9 13/16	248.9	1 9/16	39.4	3 1/4	81.8	5 5/8	142.7	5 3/8	136.9	-	-	6 7/8	175.3	6 7/16	163.6	-	-	3.61	1.64
1 1/2	40	5 1/2	140.2	11 3/4	297.9	16 3/4	426.0	1 7/8	47.5	4 9/16	115.8	6 13/16	142.7	6 11/16	169.9	-	-	8 1/16	205.2	7 7/8	199.6	-	-	9.27	4.20
2	50	5 1/2	140.2	11 3/4	297.9	16 3/4	426.0	1 7/8	47.5	4 9/16	115.8	6 13/16	173.5	6 15/16	176.5	-	-	8 1/2	206.8	8 3/8	212.9	-	-	9.59	4.35

# Series N55B and LFN55B

## Water Pressure Reducing Valves

Sizes: ½" – 1" (15 – 25mm)

Series N55B-M1 and LFN55B-M1 Water Pressure Reducing Valves are designed to reduce incoming water pressure to a sensible level to protect plumbing system components and reduce water consumption. The LFN55B features Lead Free\* construction to comply with Lead Free\* Installation requirements. This series is suitable for water supply pressures up to 400psi (27.6 bar) and may be adjusted from 25 – 75psi (172 – 517kPa). The standard setting is 50psi (345kPa). All parts are quickly and easily serviceable without removing the valve from the line. The standard bypass feature permits the flow of water back through the valve into the main when pressures, due to thermal expansion on the outlet side of the valve, exceed the pressure in the main.

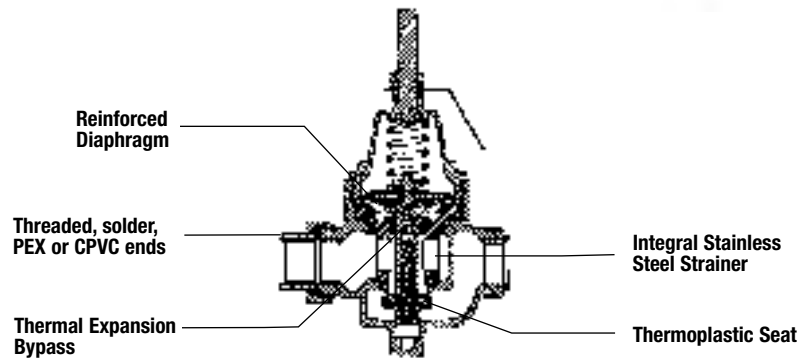

### Features

- Double union inlet & outlet connections (option DU)
- Integral stainless steel strainer
- Thermoplastic seat
- Bronze body construction
- Lead Free\* models with Lead Free\* brass body construction
- Serviceable in line
- Bypass feature controls thermal expansion pressure\*
- Sealed spring cage on all models for accessible outdoors or pit installations

### Models

N55B-M1	NPT threaded female inlet x NPT female outlet
LF N55B-M1	NPT threaded female inlet x NPT female outlet
N55BU-M1	NPT threaded union inlet x NPT female outlet
LFN55BU-M1	NPT threaded union inlet x NPT female outlet
N55BU-S-M1	Solder union inlet x NPT female outlet
LF N55BU-S-M1	Solder union inlet x NPT female outlet
N55BDU-M1	Double Union – NPT threaded union female inlet and outlet
LFN55BDU-M1	Double Union – NPT threaded union female inlet and outlet
N55BDU-S-M1	Double Union – Solder union inlet and outlet
LF N55BDU-S-M1	Double Union – Solder union inlet and outlet
N55BDU-PEX-M1	Double Union – PEX union inlet and outlet
LF N55BDU-PEX-M1	Double Union – PEX union inlet and outlet
N55BDU-CPVC-M1	Double Union – CPVC union inlet and outlet
LFN55BDU-CPVC-M1	Double Union – CPVC union inlet and outlet
N55BDU-QC-M1	Double Union – Quick-Connect inlet and outlet
LFN55BDU-QC-M1	Double Union – Quick-Connect inlet and outlet
N55BU-QC-M1	Single Union – Quick-Connect inlet
LF N55BU-QC-M1	Single Union – Quick-Connect inlet

### Pressure – Temperature

Temperature Range: 33°F – 180°F (0.5°C – 82°C)  
 Maximum Working Pressure: 400psi (27.6 bar)  
 Adjustable Reduced Pressure Range: 25 – 75psi (172 – 517kPa)  
 Standard Reduced Pressure Setting: 50psi (345kPa)

### Options

#### add Suffix:

- G Gauge tapping ⅛" (3mm)
- GG Gauge tapping and 160psi (11 bar) gauge
- LP Low pressure range 10-35psi (69-241 kPa)

#### add Prefix:

- LF Lead Free\* construction

### Standards



Meets requirements of ASSE Standard 1003; (ANSI A112.26.2); CSA Standard B356; Certified by NSF to ANSI/NSF Standard 61-8, (LF N55B-M1 models only). Listed by IAPMO and City of Los Angeles.

\*The wetted surface of this product contacted by consumable water contains less than one quarter of one percent (0.25%) of lead by weight.  
**Note:** The bypass feature will not prevent the pressure relief valve from opening on the hot water supply system with pressures above 150psi.

## Capacity

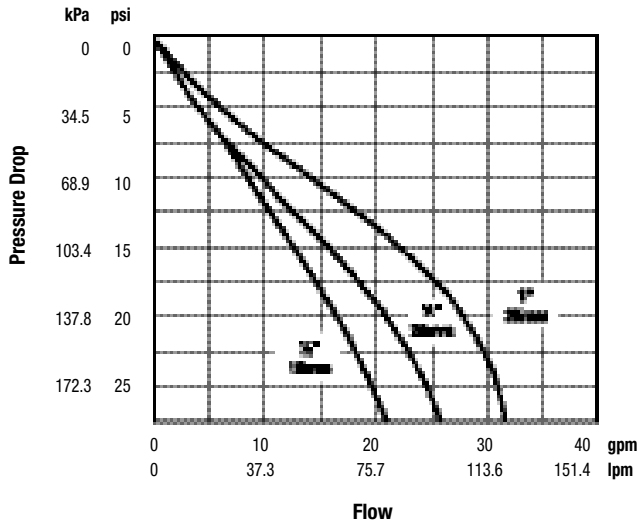

## Dimensions — Weights

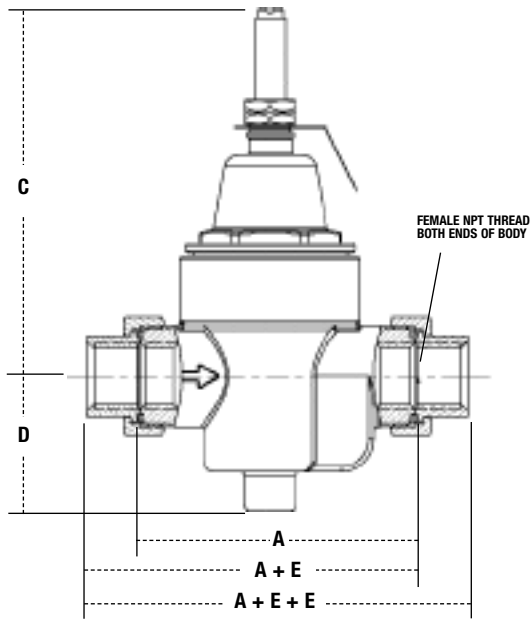

ABOVE VALVE SHOWN WITH SINGLE NPT UNION CONNECTION ON INLET  
VALVES MAY BE ORDERED WITH 0.1 OR 2 UNION CONNECTIONS USING ANY  
COMBINATION OF NPT, SOLDER, PEX OR CPVC CONNECTIONS REQUIRED  
\*F\* DIMENSIONS ARE APPROXIMATE ENGAGEMENT LENGTHS.

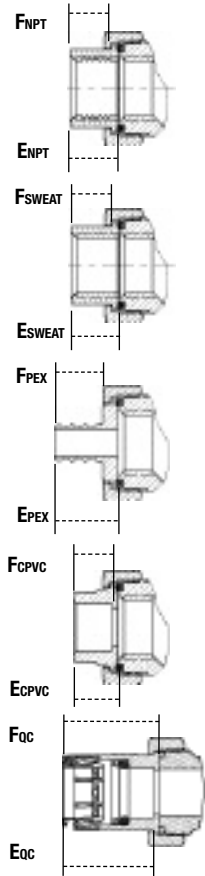

SIZE (DN)	DIMENSIONS (APPROX.)															WEIGHT			
	A		C		D		ENPT	ESWEAT	EPEX	E	Eoc	FNPT	FSWEAT	FPEX	Fcpvc	Foc	G	lbs.	kgs.
in. mm	in. mm	in. mm	in. mm	in. mm	in. mm	in. mm	in. mm	in. mm	in. mm	in. mm	in. mm	in. mm	in. mm	in. mm	in. mm	in. mm	in. mm		
1/2 15	3 7/16 88	4 9/16 116	1 11/16 43	5/8 16	5/8 15	13/16 21	9/16 15	1 7/16 36	1/2 13	1/2 13	5/8 16	1/2 13	1 1/2 38	2 1/4 57	2 .91				
3/4 20	3 7/16 88	4 9/16 116	1 11/16 43	5/8 16	7/8 21	1 5/16 24	13/16 21	1 9/16 40	9/16 14	3/4 19	5/8 16	3/4 18	1 11/16 42	2 1/4 57	2 .91				
1 25	4 1/8 105	4 9/16 116	1 11/16 43	3/4 20	1 26	1 1/8 29	1 1/16 26	1 11/16 43	1 1/16 17	1 5/16 23	1 3/4 21	1 5/16 23	1 3/4 45	2 1/4 57	3 1.36				

# Series N55B and LFN55B

## Water Pressure Reducing Valves

Sizes: 1¼" – 2" (32 – 50mm)

Series N55B and LFN55B Water Pressure Reducing Valves are designed to reduce incoming water pressure to a sensible level to protect plumbing system components and reduce water consumption. The LFN55B features Lead Free\* construction to comply with Lead Free\* installation requirements. This series is suitable for water supply pressures up to 300psi (21 bar) and may be adjusted from 25 – 75psi (172 – 517 kPa). The standard setting is 50psi (345 kPa). All parts are quickly and easily serviceable without removing the valve from the line. The standard bypass feature permits the flow of water back through the valve into the main when pressures, due to thermal expansion on the outlet side of the valve, exceed the pressure in the main.

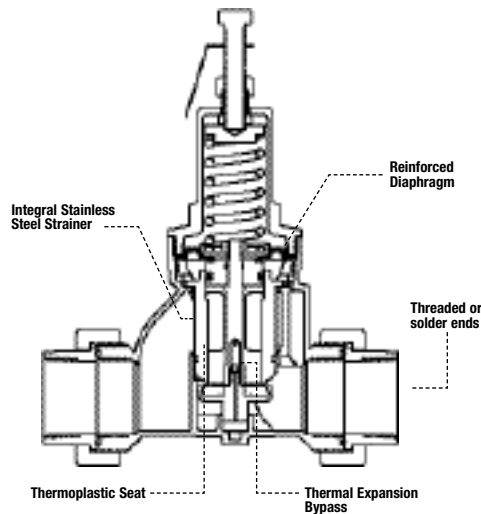

### Features

- Bronze cage
- Double union inlet & outlet connections
- Integral stainless steel strainer
- Thermoplastic seat
- Bronze body construction
- Lead Free\* models with Lead Free\* brass body construction
- Serviceable in line
- Bypass feature controls thermal expansion pressure\*
- Sealed spring cage on all models for accessible outdoors or pit installations

### Models

N55B	NPT threaded female inlet x
LFN55B	NPT female outlet
N55BU	NPT threaded union inlet x
LFN55BU	NPT female outlet
N55BU-S	Solder union x
LFN55BU-S	NPT female outlet
N55BDU	Double Union – NPT threaded
LFN55BDU	union female inlet and outlet
N55BDU-S	
LFN55BDU-S	Double Union – Solder union inlet and outlet

### Options

#### add Suffix:

- G Gauge tapping 1/8" (3mm)
- GG Gauge tapping and 160psi (11 bar) gauge

#### add Prefix:

- LF Lead Free\* construction

### Pressure – Temperature

Temperature Range: 33°F – 180°F  
(0.5°C – 82°C)

Maximum Working Pressure: 300psi  
(21 bar)

Adjustable Reduced Pressure Range:  
25 – 75psi (172 – 517 kPa)

Standard Reduced Pressure Setting:  
50psi (345 kPa)

### Standards



Meets requirements of ASSE Standard 1003; (ANSI A112.26.2); CSA Standard B356; and listed by IAPMO.

\*The wetted surface of this product contacted by consumable water contains less than one quarter of one percent (0.25%) of lead by weight.  
**Note:** The bypass feature will not prevent the pressure relief valve from opening on the hot water supply system with pressures above 150psi.

## Capacity

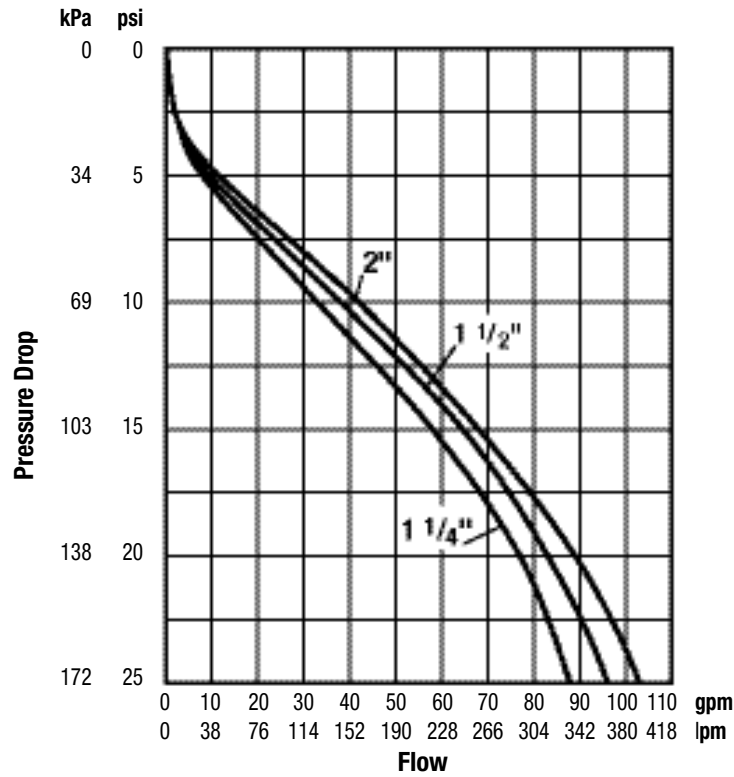

## Dimensions — Weights

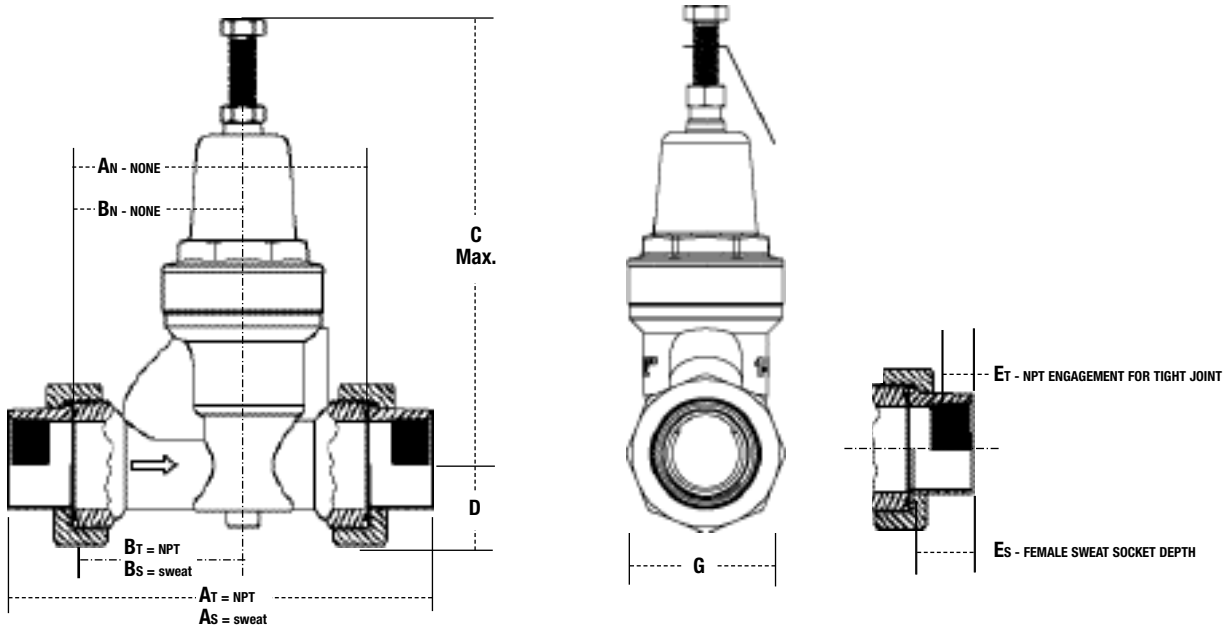

SIZE (DN)		DIMENSIONS (APPROX.)												WEIGHTS											
in.	mm	A <sub>T</sub>	A <sub>S</sub>	A <sub>N</sub>	B <sub>T</sub>	B <sub>S</sub>	B <sub>N</sub>	C	D	E <sub>T</sub>	E <sub>S</sub>	G	lbs.	kgs.											
		in.	mm	in.	mm	in.	mm	in.	mm	in.	mm	in.	mm	in.	mm										
1 1/4	32	8 3/8	213	7 15/16	201	5 13/16	148	4 3/8	111	4 1/8	105	3 1/16	78	8 7/8	225	1 7/16	36	1 1/16	17	1	25	3 1/4	82	7.5	3.4
1 1/2	40	8 3/8	213	8 3/16	207	5 13/16	148	4 9/16	115	4 7/16	112	3 1/4	83	8 7/8	225	1 5/8	41	1 1/16	17	1 1/8	28	3 1/4	82	9	4.0
2	50	9	228	9 1/4	235	6 3/8	162	5	126	5 1/16	129	3 11/16	93	8 7/8	225	1 7/8	47	1 1/16	17	1 3/8	34	3 11/16	93	10	4.5

# Series N45B-M1 and LFN45B-M1

## Water Pressure Reducing Valves

Sizes: 1/2" – 1" (15 – 25mm)

Series N45B-M1 and LFN45B-M1 Water Pressure Reducing Valves are designed to reduce incoming water pressure to a sensible level to protect plumbing system components and reduce water consumption. The LFN45B features Lead Free\* construction to comply with Lead Free\* installation requirements. This series is suitable for water supply pressures up to 400psi (27.6 bar) and may be adjusted from 25 – 75psi (172 – 517 kPa). The standard setting is 50psi (345 kPa). All parts are quickly and easily serviceable without removing the valve from the line. The standard bypass feature permits the flow of water back through the valve into the main when pressures, due to thermal expansion on the outlet side of the valve, exceed the pressure in the main.

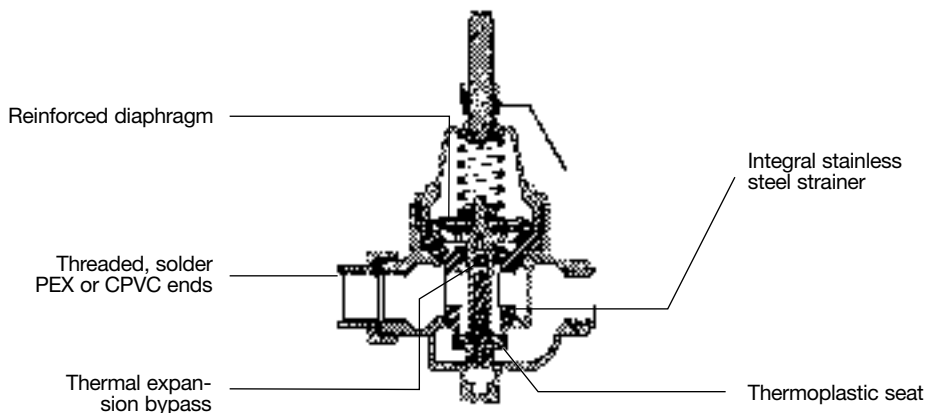

### Features

- Double union inlet & outlet connections (option DU)
- Integral stainless steel strainer
- Thermoplastic seat & cage
- Bronze body construction
- Lead Free\* models with Lead Free\* brass body construction
- Serviceable in line
- Bypass feature controls thermal expansion pressure\*
- Sealed spring cage on all models for accessible outdoors or pit installations

### Models

N45B-M1	NPT threaded female inlet x NPT female outlet
LFN45B-M1	NPT threaded union inlet x NPT female outlet
N45BU-M1	Solder union inlet x NPT female outlet
LFN45BU-M1	Solder union inlet x NPT female outlet
N45BDU-M1	Double Union – NPT threaded union female inlet and outlet
LF N45BDU-M1	Double Union – NPT threaded union female inlet and outlet
N45BDU-S-M1	Double Union – Solder union inlet and outlet
LFN45BDU-S-M1	Double Union – Solder union inlet and outlet
N45BDU-PEX-M	Double Union – PEX union inlet and outlet
LFN45BDU-PEX-M1	Double Union – PEX union inlet and outlet
N45BDU-CPVC-M1	Double Union – CPVC union inlet and outlet
LFN45BDU-CPVC-M1	Double Union – CPVC union inlet and outlet
N45BDU-QC-M1	Double Union Quick-Connect inlet and outlet
LFN45BDU-QC-M1	Double Union Quick-Connect inlet and outlet
N45DU-QC-M1	Single Union Quick-Connect inlet
LFN45DU-QC-M1	Single Union Quick-Connect inlet

### Options

#### add Suffix:

- G Gauge tapping 1/8" (3mm)
- GG Gauge tapping and 160psi (11 bar) gauge

#### add Prefix:

- LF Lead Free\* construction

### Pressure – Temperature

Temperature Range: 33°F – 180°F (0.5°C – 82°C)

Maximum Working Pressure: 400psi (27.6 bar)

Adjustable Reduced Pressure Range: 25 – 75psi (172 – 517 kPa)

Standard Reduced Pressure Setting: 50psi (345 kPa)

### Standards



Meets requirements of ASSE Standard 1003; (ANSI A112.26.2) and CSA Standard B356; Certified by NSF to ANSI/NSF Standard 61-8, (LF N45B-M1 models only). Listed by IAPMO and City of Los Angeles.

\*The wetted surface of this product contacted by consumable water contains less than one quarter of one percent (0.25%) of lead by weight.

**Note:** The bypass feature will not prevent the pressure relief valve from opening on the hot water supply system with pressures above 150psi.

## Capacity

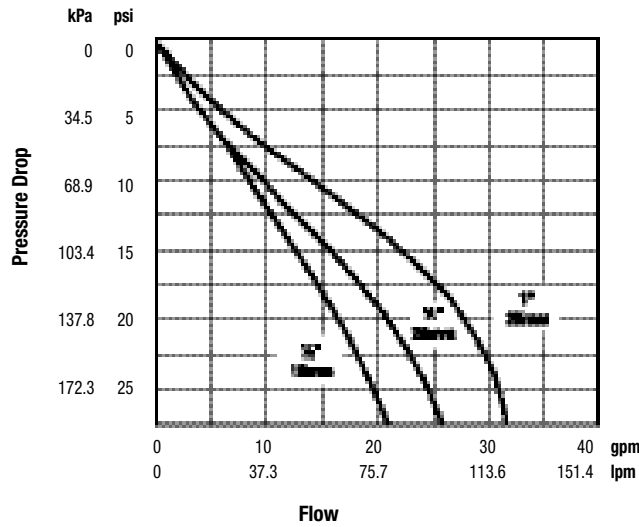

## Dimensions — Weights

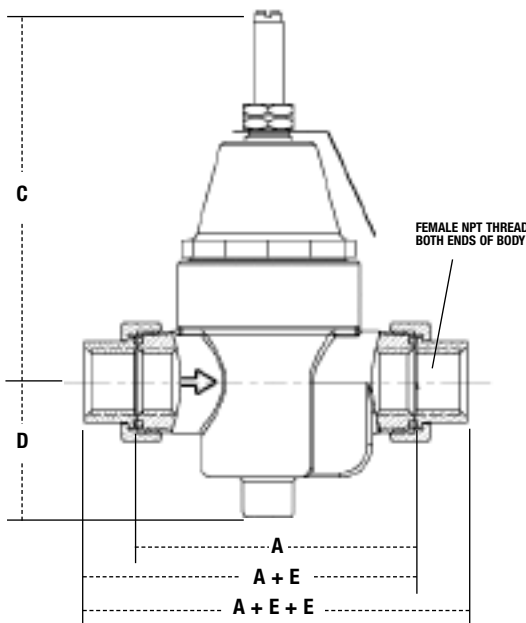

ABOVE VALVE SHOWN WITH SINGLE NPT UNION CONNECTION ON INLET  
 VALVES MAY BE ORDERED WITH 0, 1, OR 2 UNION CONNECTIONS USING ANY  
 COMBINATION OF NPT, SOLDER, PEX OR CPVC CONNECTIONS REQUIRED  
 \*F\* DIMENSIONS ARE APPROXIMATE ENGAGEMENT LENGTHS.

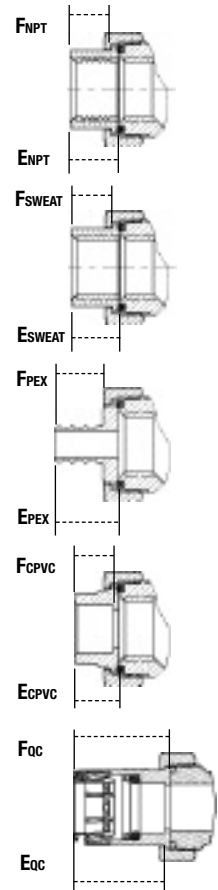

SIZE (DN)		DIMENSIONS (APPROX.)														WEIGHT	
in.	mm	A	C	D	ENPT	ESWEAT	EPEX	ECPVC	Eoc	FNPT	FSWEAT	FPEX	FCPVC	Foc	G	lbs.	kgs.
1/2	15	37/16 88	49/16 116	111/16 43	5/8 16	5/8 15	13/16 21	9/16 15	17/8 36	1/2 13	1/2 13	5/8 16	1/2 13	1 1/2 38	2 1/4 57	2	.91
3/4	20	37/16 88	49/16 116	111/16 43	5/8 16	7/8 21	15/16 24	13/16 21	19/16 40	9/16 14	3/4 19	5/8 16	3/4 18	1 11/16 42	2 1/4 57	2	.91
1	25	4 1/8 105	49/16 116	111/16 43	3/4 20	1 26	1 1/8 29	1 1/16 26	1 11/16 43	1 1/16 17	15/16 23	13/16 21	15/16 23	1 3/4 45	2 1/4 57	3	1.36

# Series N45B and LFN45B

## Water Pressure Reducing Valves

Sizes: 1 1/4" – 2" (32 – 50mm)

Series N45B and LFN45B Water Pressure Reducing Valves are designed to reduce incoming water pressure to a sensible level to protect plumbing system components and reduce water consumption. The LFN45B features Lead Free\* construction to comply with Lead Free\* installation requirements. This series is suitable for water supply pressures up to 300psi (21 bar) and may be adjusted from 25 – 75psi (172 – 517 kPa). The standard setting is 50psi (345 kPa). All parts are quickly and easily serviceable without removing the valve from the line. The standard bypass feature permits the flow of water back through the valve into the main when pressures, due to thermal expansion on the outlet side of the valve, exceed the pressure in the main.

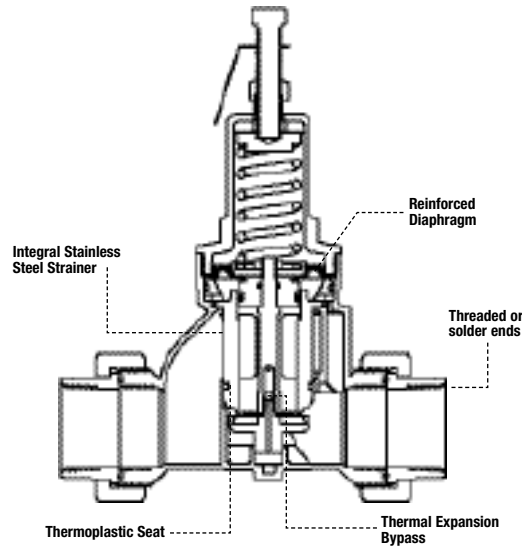

### Features

- Double union inlet & outlet connections
- Integral stainless steel strainer
- Thermoplastic seat & cage
- Bronze body construction
- Lead Free\* models with Lead Free\* brass body construction
- Serviceable in line
- Bypass feature controls thermal expansion pressure\*
- Sealed spring cage on all models for accessible outdoors or pit installations

### Models

N45B	NPT threaded female inlet
LFN45B	x NPT female outlet
N45BU	NPT threaded union inlet x
LFN45BU	NPT threaded union outlet
N45BU-S	Solder union inlet
LFN45BU-S	x NPT female outlet
N45BDU	Double Union – NPT
LFN45BDU	threaded union female inlet and outlet
N45BDU-S	Double Union – Solder
LFN45BDU-S	union inlet and outlet

### Options

#### add Suffix:

- G Gauge tapping
- GG Gauge tapping and 160psi (11 bar) gauge

### Pressure – Temperature

Temperature Range: 33°F – 180°F  
(0.5°C – 82°C)  
Maximum Working Pressure: 300psi  
(21 bar)  
Adjustable Reduced Pressure Range:  
25 – 75psi (172 – 517 kPa)  
Standard Reduced Pressure Setting:  
50psi (345 kPa)

Standards   

Meets requirements of ASSE Standard 1003; (ANSI A112.26.2); CSA Standard B356; and listed by IAPMO. City of Los Angeles.

\*The wetted surface of this product contacted by consumable water contains less than one quarter of one percent (0.25%) of lead by weight.  
**Note:** The bypass feature will not prevent the pressure relief valve from opening on the hot water supply system with pressures above 150psi.

## Capacity

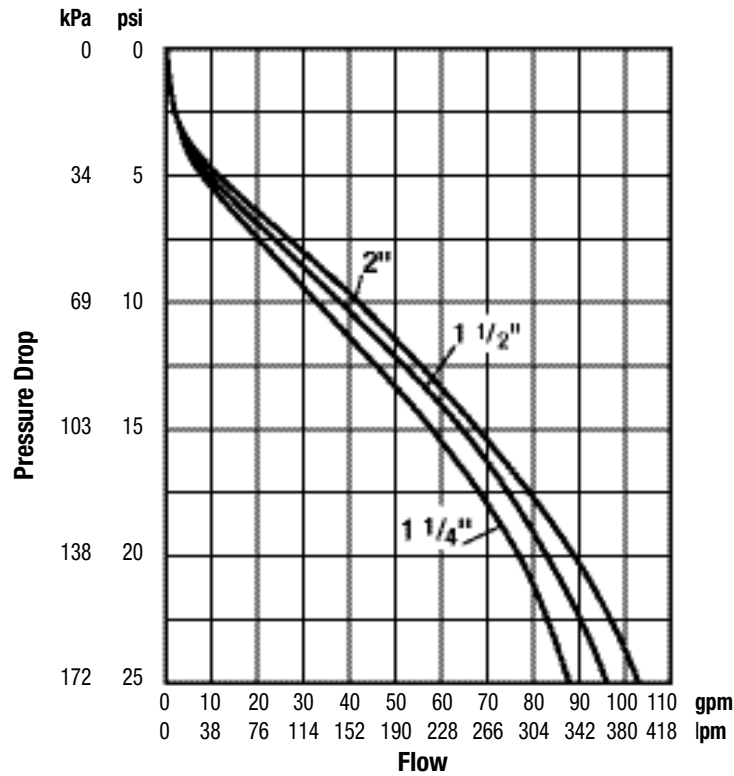

## Dimensions — Weights

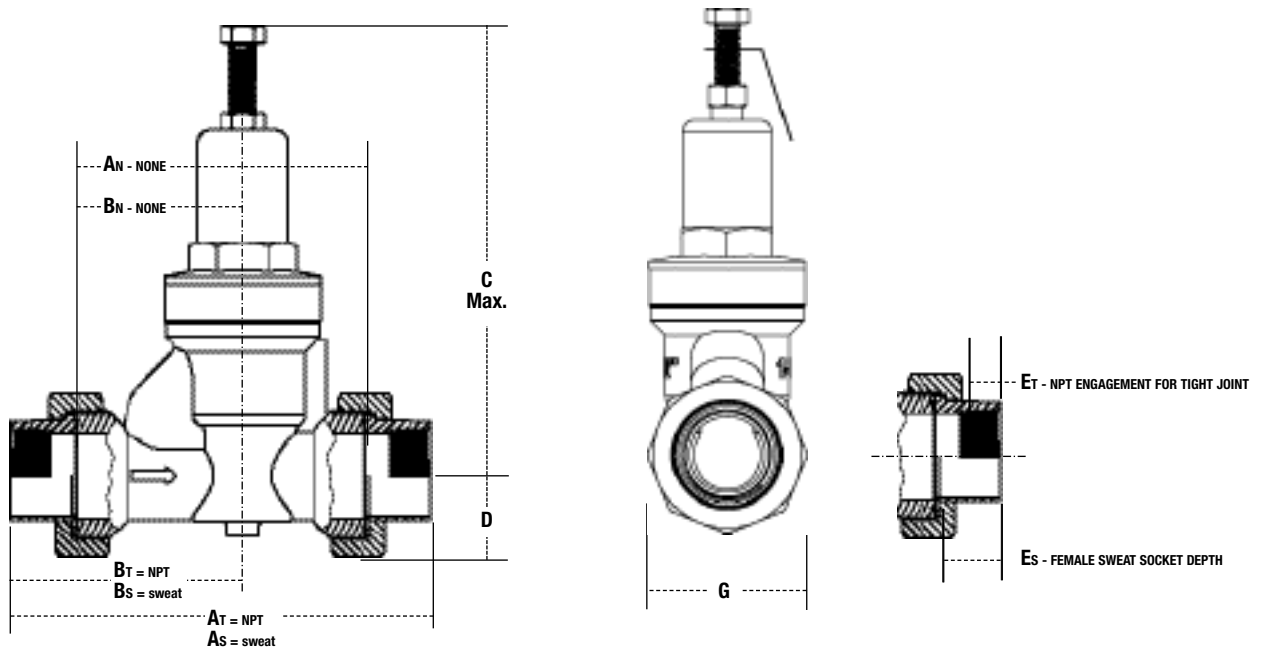

SIZE (DN)		DIMENSIONS (APPROX.)												WEIGHT											
in.	mm	A <sub>T</sub> in.	A <sub>S</sub> mm	A <sub>N</sub> in.	A <sub>N</sub> mm	B <sub>T</sub> in.	B <sub>T</sub> mm	B <sub>S</sub> in.	B <sub>S</sub> mm	B <sub>N</sub> in.	B <sub>N</sub> mm	C in.	C mm	D in.	D mm	E <sub>T</sub> in.	E <sub>T</sub> mm	E <sub>S</sub> in.	E <sub>S</sub> mm	G in.	G mm	lbs.	kgs.		
1 1/4	32	8 3/8	213	7 15/16	201	5 13/16	148	4 3/8	111	4 7/8	105	3 1/16	78	8 7/8	225	1 7/16	36	1 1/16	17	1	25	3 1/4	82	6.5	2.9
1 1/2	40	8 3/8	213	8 3/16	207	5 13/16	148	4 9/16	115	4 7/16	112	3 1/4	83	8 7/8	225	1 5/8	41	1 1/16	17	1 1/8	28	3 1/4	82	8	3.6
2	50	9	228	9 1/4	235	6 3/8	162	5	126	5 1/16	129	3 11/16	93	8 7/8	225	1 7/8	47	1 1/16	17	1 3/8	34	3 11/16	93	9	4.1

# Series N45B-EZ-M1

## Water Pressure Reducing Valves

Sizes: 1/2" – 1" (15 – 25mm)

Series N45B-EZ-M1 Water Pressure Reducing Valves are designed to reduce incoming water pressure to a sensible level to protect plumbing system components and reduce water consumption. This series is suitable for water supply pressures up to 400psi (27.6 bar) and may be adjusted from 25 – 75psi (172 – 517kPa). The standard setting is 50psi (345kPa). All parts are quickly and easily serviceable without removing the valve from the line. The standard bypass feature permits the flow of water back through the valve into the main when pressures, due to thermal expansion on the outlet side of the valve, exceed the pressure in the main.

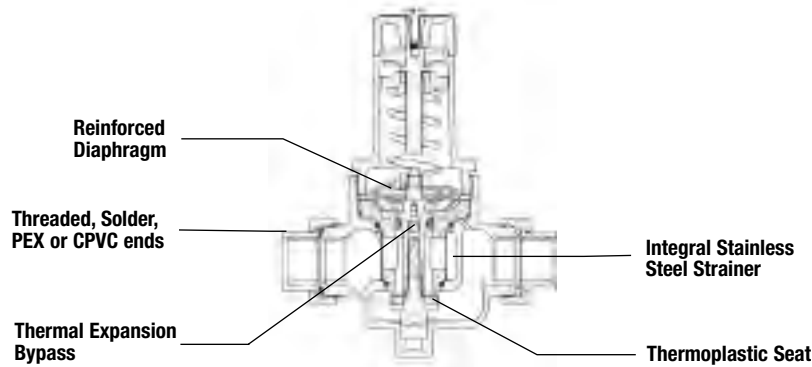

### Features

- Factory calibrated outlet pressure adjustment
- Easily adjustable pressure setting
- Double union inlet & outlet connections (option DU)
- Integral stainless steel strainer
- Thermoplastic cage & seat
- Bronze body construction
- Serviceable in line
- Bypass feature controls thermal expansion pressure\*

### Models

N45B-EZ-M1	NPT threaded female inlet x NPT female outlet
N45BU-EZ-M1	NPT threaded union inlet x NPT female outlet
N45BU-EZ-S-M1	Solder union inlet x NPT female outlet
N45BDU-EZ-M1	Double Union – NPT threaded union female inlet and outlet
N45BDU-EZ-S-M1	Double Union – Solder union inlet and outlet
N45BDU-EZ-PEX-M1	Double Union – PEX union inlet and outlet
N45BDU-EZ-CPVC-M1	Double Union – CPVC union inlet and outlet

### Options

#### add Suffix:

- G Gauge tapping
- GG Gauge tapping and 160psi (11 bar) gauge

### Pressure – Temperature

Temperature Range: 33°F – 180°F (0.5°C – 82°C)

Maximum Working Pressure: 400psi (27.6 bar)

Adjustable Reduced Pressure Range: 25-75psi (172 - 517kPa)

Standard Reduced Pressure Setting: 50psi (345kPa)

### Standards



Meets requirements of ASSE Standard 1003; (ANSI A112.26.2); CSA Standard B356; and listed by IAPMO.

**Note:** The bypass feature will not prevent the pressure relief valve from opening on the hot water supply system with pressures above 150psi.

## Capacity

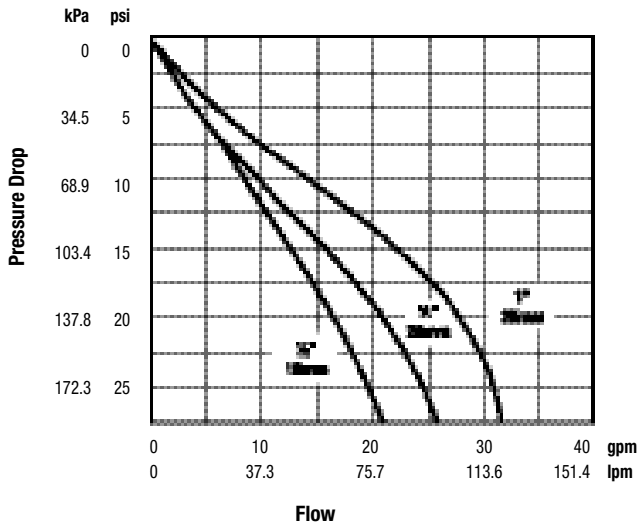

## Dimensions — Weights

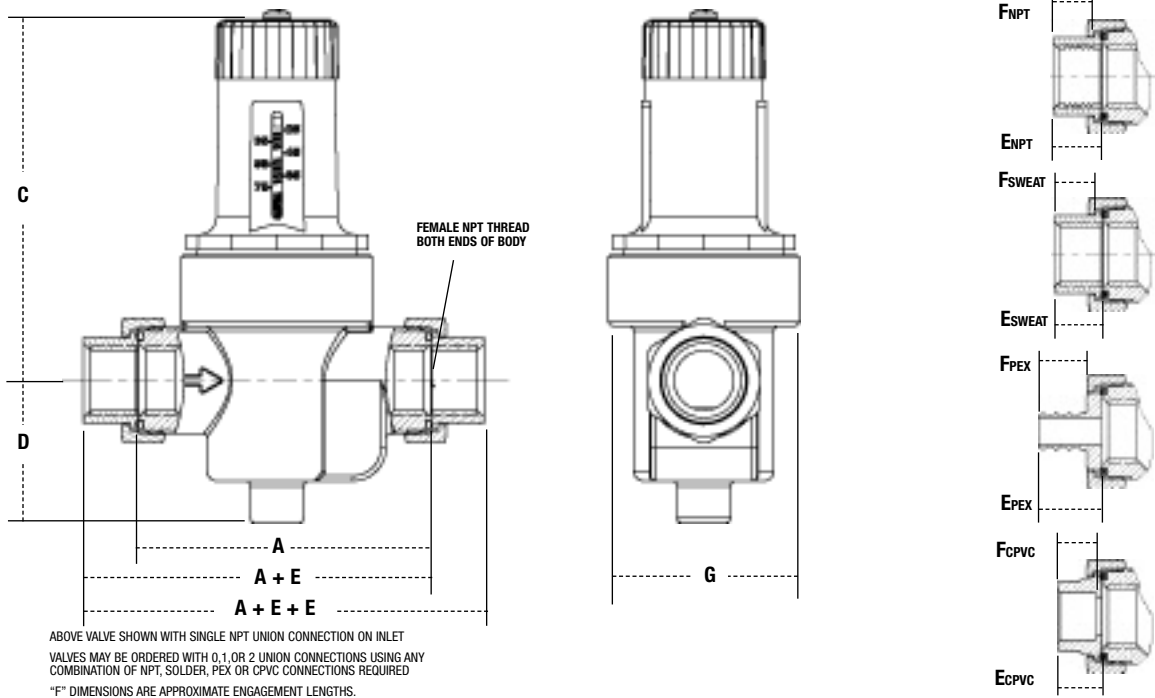

SIZE (DN)	DIMENSIONS (APPROX.)												WEIGHT				
	A		C		D		ENPT	ESWEAT	EPEX	ECPVC	F <sub>NPT</sub>	F <sub>SWEAT</sub>		F <sub>PEX</sub>	F <sub>CPVC</sub>	G	
in. mm	in. mm	in. mm	in. mm	in. mm	in. mm	in. mm	in. mm	in. mm	in. mm	in. mm	in. mm	in. mm	in. mm	in. mm	in. mm	lbs.	kgs.
1/2 15	3/16 88	4 3/8 111	1 11/16 43	5/8 16	5/8 15	13/16 21	9/16 15	1/2 13	1/2 13	5/8 16	1/2 13	2 1/4 57	1.75	.79			
3/4 20	3/16 88	4 3/8 111	1 11/16 43	5/8 16	7/8 21	15/16 24	13/16 21	9/16 14	3/4 19	5/8 16	3/4 18	2 1/4 57	1.75	.79			
1 25	4 1/8 105	4 3/8 111	1 11/16 43	3/4 20	1 26	1 1/8 29	1 1/16 26	1 1/16 17	15/16 23	13/16 21	15/16 23	2 1/4 57	2	.91			

# Series N45B-EZ

## Water Pressure Reducing Valves

Sizes: 1¼" – 2" (32 – 50mm)

Series N45B-EZ Water Pressure Reducing Valves are designed to reduce incoming water pressure to a sensible level to protect plumbing system components and reduce water consumption. This series is suitable for water supply pressures up to 300psi (21 bar) and may be adjusted from 25 – 75psi (172 – 517 kPa). The standard setting is 50psi (345 kPa). All parts are quickly and easily serviceable without removing the valve from the line. The standard bypass feature permits the flow of water back through the valve into the main when pressures, due to thermal expansion on the outlet side of the valve, exceed the pressure in the main.

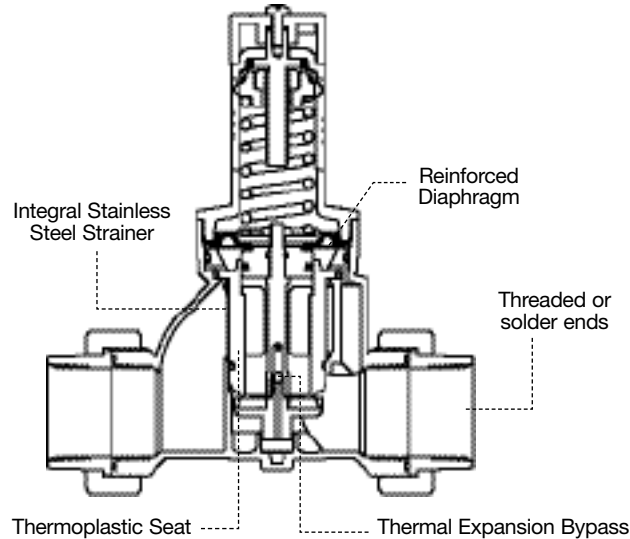

### Features

- Factory calibrated outlet pressure adjustment
- Easily adjustable pressure setting
- Double union inlet & outlet connections
- Integral stainless steel strainer
- Bronze body construction
- Serviceable in line
- Bypass feature controls thermal expansion pressure\*

### Models

N45B-EZ	NPT threaded female inlet x NPT female outlet
N45BDU-EZ	Double Union - NPT threaded union female inlet and outlet
N45BDU-EZ-S	Double Union - Solder union inlet and outlet

### Options

#### add Suffix:

- G gauge tapping
- GG gauge tapping and 160psi (11 bar) gauge

### Pressure – Temperature

Temperature Range: 33°F – 180°F  
(0.5°C – 82°C)  
Maximum Working Pressure: 300psi  
(21 bar)  
Adjustable Reduced Pressure Range:  
25 – 75psi (172 – 517 kPa)  
Standard Reduced Pressure Setting:  
50psi (345 kPa)

### Standards



Meets requirements of ASSE Standard 1003; (ANSI A112.26.2); CSA Standard B356; and listed by IAPMO.

**Note:** The bypass feature will not prevent the pressure relief valve from opening on the hot water supply system with pressures above 150psi.

## Capacity

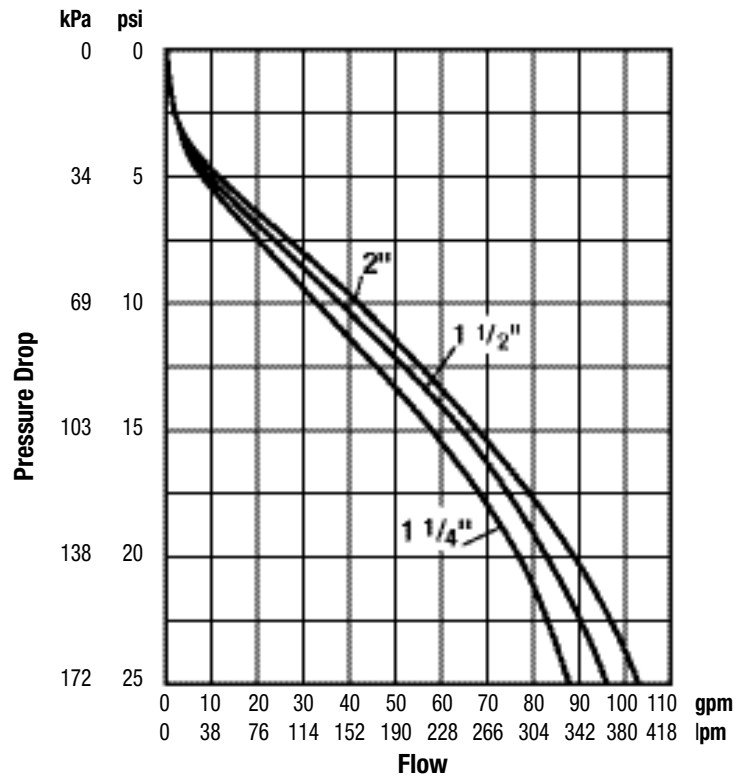

## Dimensions — Weights

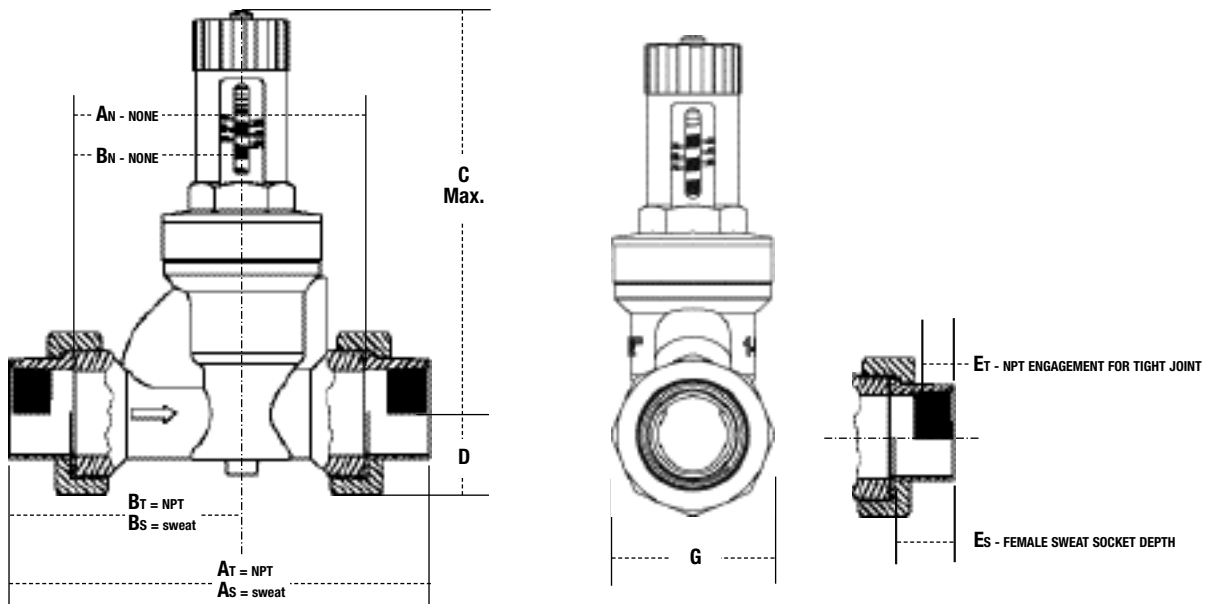

SIZE (DN)		DIMENSIONS (APPROX.)												WEIGHT											
in.	mm	A <sub>T</sub>	A <sub>S</sub>	A <sub>N</sub>	B <sub>T</sub>	B <sub>S</sub>	B <sub>N</sub>	C	D	E <sub>T</sub>	E <sub>S</sub>	G	lbs.	kgs.											
1 1/4	32	8 3/8	213	7 15/16	201	5 13/16	148	4 7/8	111	4 1/8	105	3 1/16	78	8	204	1 7/16	36	1 1/16	17	1	25	3 1/4	82	6.5	2.9
1 1/2	40	8 3/8	213	8 3/16	207	5 13/16	148	4 9/16	115	4 7/16	112	3 3/4	83	8	204	1 5/8	41	1 1/16	17	1 1/8	28	3 1/4	82	8	3.6
2	50	9	228	9 1/4	235	6 3/8	162	5	126	5 1/16	129	3 11/16	93	8	204	1 7/8	47	1 1/16	17	1 3/8	34	3 11/16	93	9	4.1

# Series 223, 223S and LF223, LF223S

## Super Capacity Water Pressure Reducing Valves

Sizes: 1/2" – 2 1/2" (15 – 65mm)

Series 223, 223S and LF223, LF223S Super Capacity Water Pressure Reducing Valves are designed to reduce incoming water pressure to a sensible level to protect plumbing system components and reduce water consumption. The LF223/LF223S features Lead Free\* construction to comply with Lead Free\* installation requirements. This series is suitable for water supply pressures up to 300psi (21 bar) and may be adjusted from 25 – 75psi (172 – 517 kPa). The standard setting is 50psi (345 kPa). Series 223 features an enlarged diaphragm, spring cage and seat orifice for super capacity performance. Series 223S/LF223S has the same options as the 223/LF223 except it is furnished with a strainer. All parts are quickly and easily serviceable without removing the valve from the line. The optional bypass feature permits the flow of water back through the valve into the main when pressures, due to thermal expansion on the outlet side of the valve, exceed the pressure in the main.

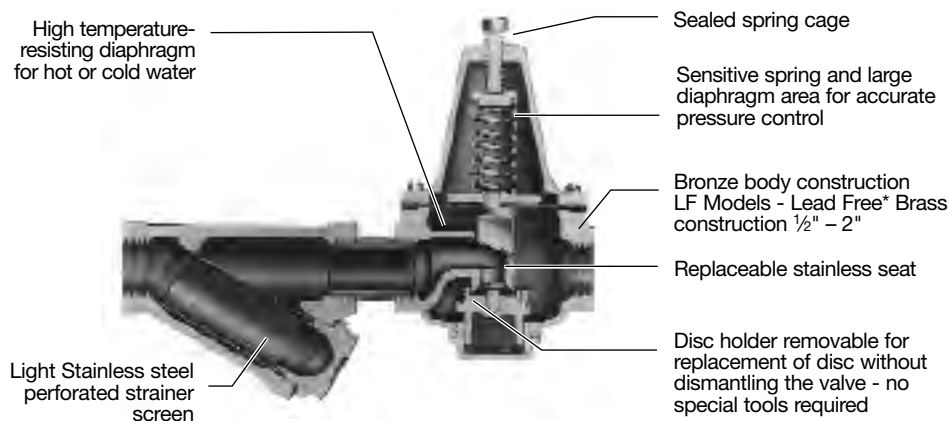
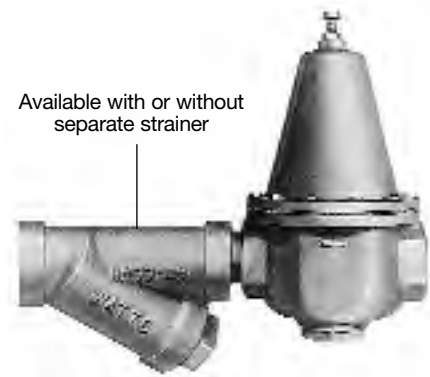

### Features

- Enlarged diaphragm, spring cage and seat orifice for super capacity performance
- Bronze body construction (except 2 1/2" which is iron)
- Lead Free\* models with Lead Free\* brass body construction (except 2 1/2" which is iron)
- Serviceable in line
- Series 223SLF223S furnished with separate strainer
- Optional bypass feature controls thermal expansion pressure\*
- Sealed spring cage on all models for accessible outdoors or pit installations

### Options

#### add Suffix:

- B Built-in bypass feature
- LP Low pressure range 10 – 35psi (5.27 – 8.79 bar)
- HP High pressure range, reduced range shown below:

REDUCED PRESSURE RANGE - SUFFIX HP			
Size		Range	
in.	mm	psi	bar
1/2	15	50-145	3.52-10.19
3/4	20	50-145	3.52-10.19
1	25	50-145	3.52-10.19
1 1/4	32	50-120	3.52-8.44
1 1/2	40	50-95	3.52-6.68
2	50	50-95	3.52-6.68
2 1/2	65	50-95	3.52-6.68

### Models

223	NPT threaded female inlet x
LF223	NPT threaded female outlet
223-S	NPT threaded female inlet x
LF223-S	NPT female threaded outlet with strainer

#### add Prefix:

- LF Lead Free\* construction

### Pressure – Temperature

Temperature Range: 33°F – 160°F (0.5°C – 71°C)  
 Maximum Working Pressure: 300psi (21 bar)  
 Adjustable Reduced Pressure Range: 25 – 75psi (172 – 517 kPa)  
 Standard Reduced Pressure Setting: 50psi (345 kPa)



### Standards

1/2" – 2" (15 – 50mm) meets requirements of ASSE Standard 1003; (ANSI A112.26); CSA Standard B356; Southern Standard Plumbing Code, Military Standard MIL-V-18146B and listed by IAPMO.

\*The wetted surface of this product contacted by consumable water contains less than one quarter of one percent (0.25%) of lead by weight.  
**Note:** The bypass feature will not prevent the pressure relief valve from opening on the hot water supply system with pressures above 150psi.

## Capacity

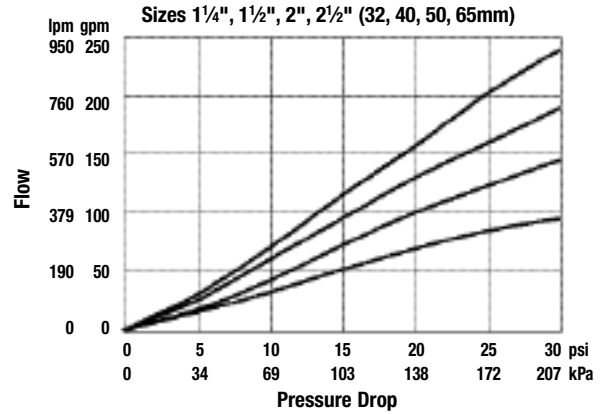
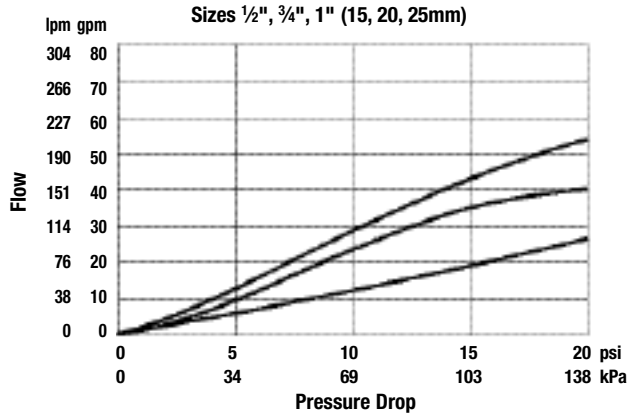

## Dimensions — Weights

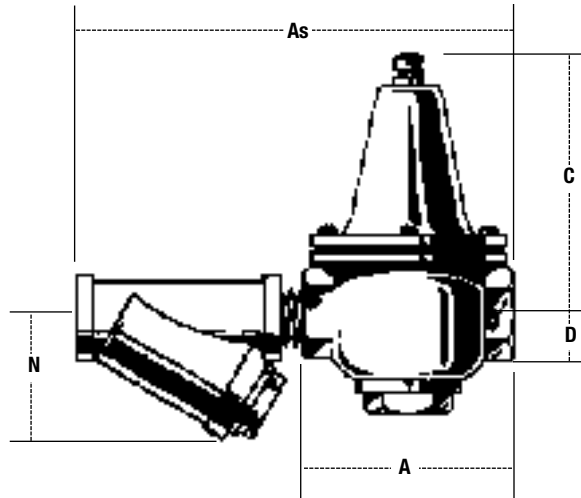

SIZE (DN)		DIMENSIONS (APPROX.)								WEIGHT					
in	mm	A (223)		As (223S)		C		D		N (223S)		223		223S	
		in	mm	in	mm	in	mm	in	mm	in	mm	lbs.	kgs.	lbs.	kgs.
1/2	15	4 1/4	108	9	229	6 1/4	159	2	50	2 1/2	64	4.5	2.0	6	2.7
3/4	20	4 1/4	108	9	229	6 1/4	159	2	50	2 1/2	64	5	2.3	6.5	2.9
1	25	4 3/4	121	10 15/16	262	6 1/2	165	2 1/8	54	2 15/16	75	7	3.2	9.5	4.3
1 1/4	32	5	127	11 15/16	287	6 3/4	172	2 3/4	70	3	76	9	4.1	12	5.4
1 1/2	40	6 3/4	171	14 3/4	375	9 7/8	251	2 3/4	70	3 7/16	87	19.5	8.8	23.5	10.7
2	50	8	203	16 3/4	425	10 3/4	273	3 3/8	86	4	102	30	13.6	37.5	17.0
2 1/2	65	9	229	20 1/8	511	10 3/4	273	3 3/8	86	5	127	32.5	14.8	59	26.8

# Series N223B, N223BS and LFN223B, LFN223BS

## Super Capacity Water Pressure Reducing Valves

Sizes: 2½" – 3" (65 – 80mm)

Series N223B, N223BS and LFN223B, LFN223BS Super Capacity Water Pressure Reducing Valves are designed to reduce incoming water pressure to a sensible level to protect plumbing system components and reduce water consumption. The LFN223B/LFN223BS features Lead Free\* construction to comply with the Lead Free\* installation requirements. This series is suitable for water supply pressures up to 300psi (21 bar) and may be adjusted from 25 – 75psi (172 – 517 kPa). The standard setting is 50psi (345 kPa). Series N223B features an enlarged diaphragm, spring cage and seat orifice for super capacity performance. Series N223BS/LFN223BS has the same options as the N223B/LFN223BS, except it is furnished with a strainer. All parts are quickly and easily serviceable without removing the valve from the line. The standard bypass feature permits the flow of water back through the valve into the main when pressures, due to thermal expansion on the outlet side of the valve, exceed the pressure in the main.

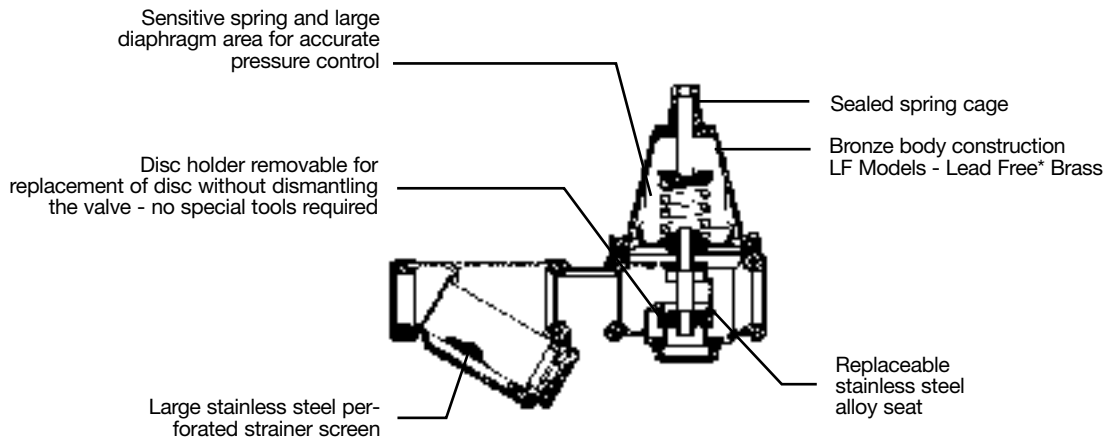

### Features

- Enlarged diaphragm, spring cage and seat orifice for super capacity performance
- Bronze body construction
- Lead Free\* models with Lead Free\* brass body construction
- Serviceable in line
- Series N223BS/ LFN223BS furnished with separate strainer
- Standard bypass feature controls thermal expansion pressure\*
- Sealed spring cage on all models for accessible outdoors or pit installations

### Models

N223B	NPT threaded female inlet x NPT threaded female outlet
LFN223B	NPT threaded female inlet x NPT threaded female outlet with strainer

### Options

#### add Suffix:

HP High pressure range 75 – 125psi (172 – 517 kPa)

### Pressure – Temperature

Temperature Range: 33°F – 160°F (0.5°C – 71°C)

Maximum Working Pressure: 300psi (21 bar)

Adjustable Reduced Pressure Range: 25 – 75psi (172 – 517 kPa)

Standard Reduced Pressure Setting: 50psi (345 kPa)

### Standards



2½" only



2½" meets requirements of ASSE Standard 1003; (ANSI A112.26) and all sizes are IAPMO listed.

\*The wetted surface of this product contacted by consumable water contains less than one quarter of one percent (0.25%) of lead by weight.

**Note:** The bypass feature will not prevent the pressure relief valve from opening on the hot water supply system with pressures above 150psi.

## Capacity

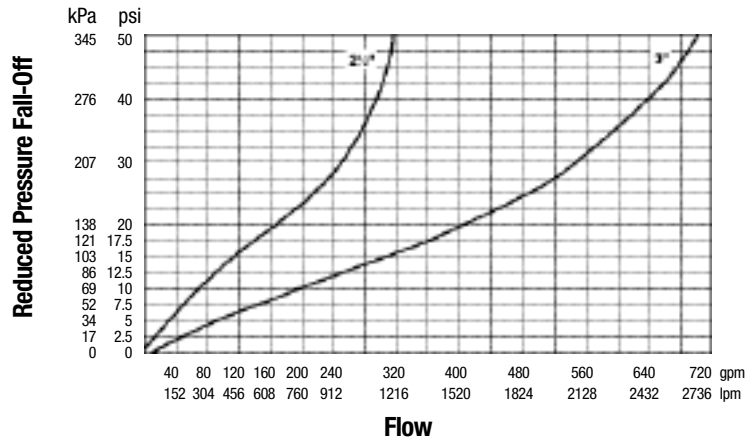

## Dimensions — Weights

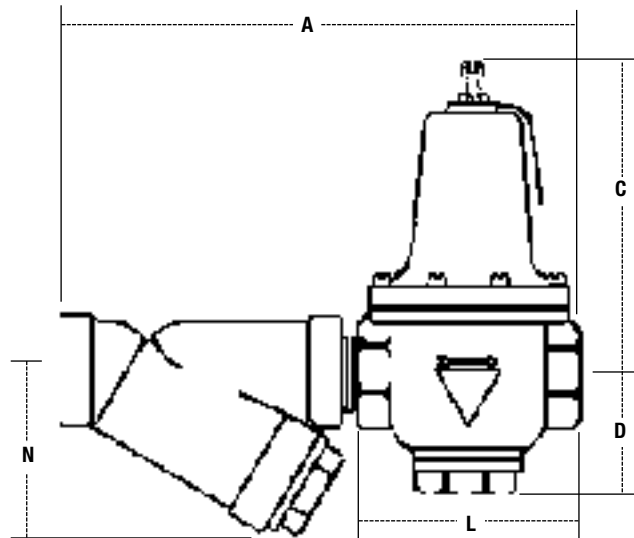

SIZE (DN)		DIMENSIONS (APPROX.)										WEIGHT			
In.	mm	A (N223BS)		C		D		L		N (N223BS)		N223B		N223BS	
		In.	mm	In.	mm	In.	mm	In.	mm	In.	mm	lbs.	kgs.	lbs.	kgs.
2 1/2	65	17	432	10 3/4	273	2 7/8	73	7 1/8	200	5	127	30	13.6	44	20.0
3	80	20 3/4	527	12 3/4	324	4 1/8	105	10 1/2	267	6 3/4	172	71	32.2	95	43.0

# Series N223F, N223FS

## Flanged Super Capacity Water Pressure Reducing Valves



### Size: 3" (80mm)

Series N223F and N223FS Flanged Super Capacity Water Pressure Reducing Valves are designed to reduce incoming water pressure to a sensible level to protect plumbing system components and reduce water consumption. This series is suitable for water supply pressures up to 175psi (12 bar) and may be adjusted from 25 – 75psi (172 – 517 kPa). The standard setting is 50psi (345 kPa). Series N223F features an enlarged diaphragm, spring cage and seat orifice for super capacity performance. These valves also contain a semi-balanced piston feature to assure rapid response to reduced pressure changes as well as to provide maximum flow with minor pressure drop. Series N223FS has the same options as the N223F, except it is furnished with a strainer. All parts are quickly and easily serviceable without removing the valve from the line. The optional bypass feature permits the flow of water back through the valve into the main when pressures, due to thermal expansion on the outlet side of the valve, exceed the pressure in the main.

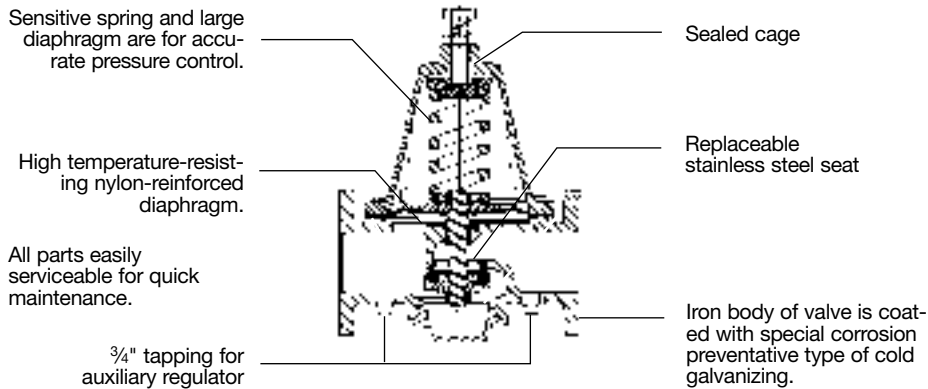

**Note:** Companion flange size connections are 125 lbs. WSP.

### Features

- Enlarged diaphragm, spring cage and seat orifice for super capacity performance
- Iron body construction
- Stainless steel piston
- Series N223FS furnished with separate strainer
- Optional bypass feature controls thermal expansion pressure\*
- Sealed spring cage on all models for accessible outdoors or pit installations

### Models

N223F	Flanged inlet x Flanged outlet
N223S	Flanged inlet x Flanged outlet with strainer

### Pressure – Temperature

Temperature Range: 33°F – 160°F (0.5°C – 71°C)  
 Maximum Working Pressure: 175psi (12 bar)  
 Adjustable Reduced Pressure Range: 25 – 75psi (172 – 517 kPa)  
 Standard Reduced Pressure Setting: 50psi (345 kPa)

### Options

#### add Suffix:

B	Built-in bypass feature
WR	3/4" (20mm) Model 223 auxiliary regulator (piping not included)

\*The wetted surface of this product contacted by consumable water contains less than one quarter of one percent (0.25%) of lead by weight.  
**Note:** The bypass feature will not prevent the pressure relief valve from opening on the hot water supply system with pressures above 150psi.

## Capacity

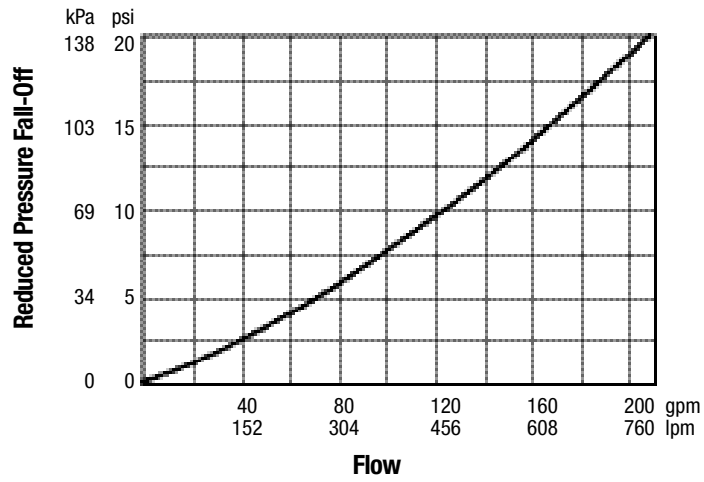

## Dimensions — Weights

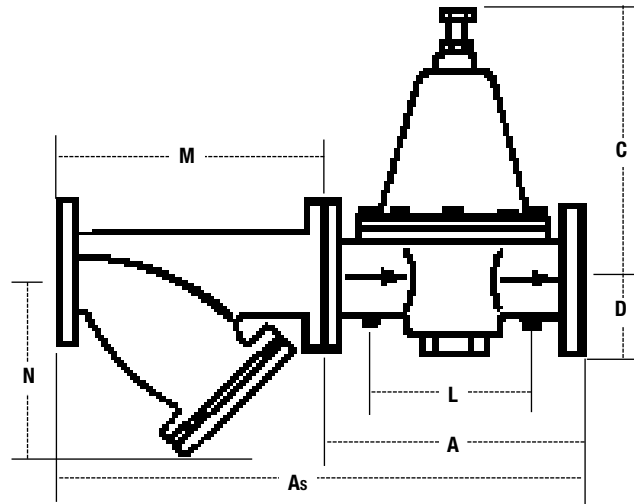

SIZE (DN)		DIMENSIONS (APPROX.)								STRAINER DIMENSIONS				WEIGHT					
		A		As (N223FS)		C		D		L		M		N		N223F		N223FS	
<i>in.</i>	<i>mm</i>	<i>in.</i>	<i>mm</i>	<i>in.</i>	<i>mm</i>	<i>in.</i>	<i>mm</i>	<i>in.</i>	<i>mm</i>	<i>in.</i>	<i>mm</i>	<i>in.</i>	<i>mm</i>	<i>in.</i>	<i>mm</i>	<i>lbs.</i>	<i>kgs.</i>	<i>lbs.</i>	<i>kgs.</i>
3	80	12½	318	22⅝	575	14½	368	3¾	95	7½	191	10⅛	257	7	178	86	39	120	54

# Series 127W, F127W and LF127W

## Flanged High Capacity Water Pressure Reducing Valves

Sizes: 3" – 4" (80 – 100mm)

Series 127W, F127W and LF127W Flanged High Capacity Water Pressure Reducing Valves are designed to reduce incoming water pressure to a sensible level to protect plumbing system components and reduce water consumption. The 127W, F127W and LF127W is a remote control type regulator ideal for commercial and industrial applications where a regulator must reach full capacity with a minor drop in reduced pressure. This series is also suitable for applications where close pressure regulation is required through extensive volume demand. This series is suitable for water supply pressures up to 175psi (12.1 bar) and may be adjusted from 25 – 100psi (172 – 690 kPa). All parts are quickly and easily serviceable.

The LF127W features Lead Free\* construction to comply with Lead Free\* installation requirements.

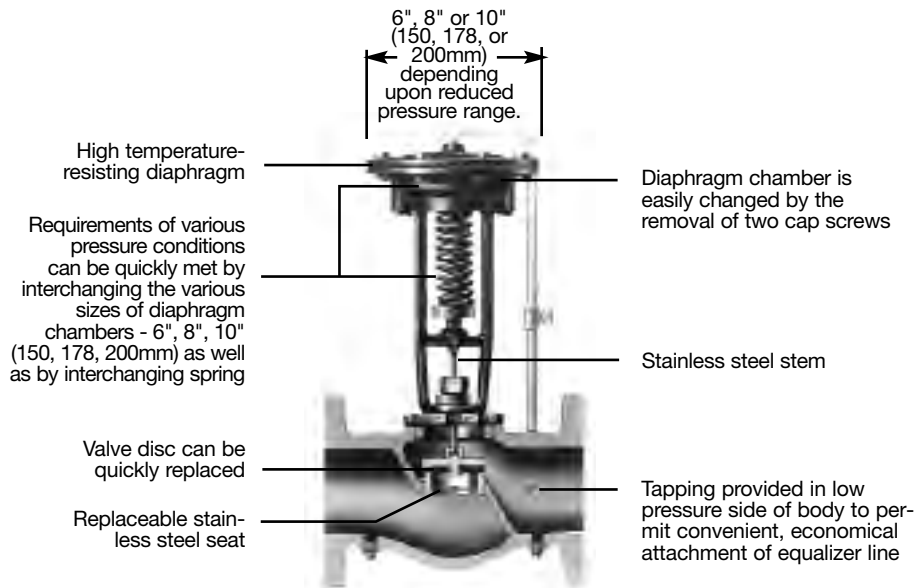
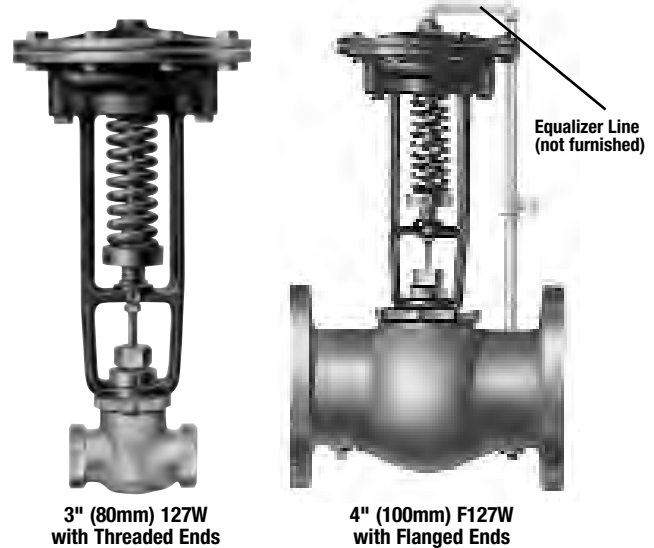

### Features

- Replaceable stainless steel seat
- Outstanding maintenance features
- Close control of reduced pressure
- High temperature-resisting diaphragm
- Interchangeable diaphragm chamber
- 127W – Bronze body
- Lead Free\* models with Lead Free\* brass body construction
- F127W Iron body triple coated with special corrosion preventative materials superior to hot dip galvanizing

### Pressure – Temperature

Temperature Range: 33°F – 160°F (0.5°C – 71°C)  
 Maximum Working Pressure: 175psi (12.1 bar)  
 Adjustable Reduced Pressure Range: 25 – 100psi (172 – 690 kPa)

### Options (4" F127W only)

#### add Suffix:

WR 3/4" (20mm) Model 223 auxiliary regulator. (Piping not included)

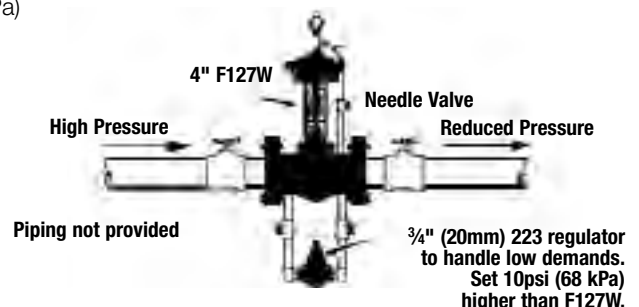

\*The wetted surface of this product contacted by consumable water contains less than one quarter of one percent (0.25%) of lead by weight.

**Note:** The bypass feature will not prevent the pressure relief valve from opening on the hot water supply system with pressures above 150psi.

## Capacity

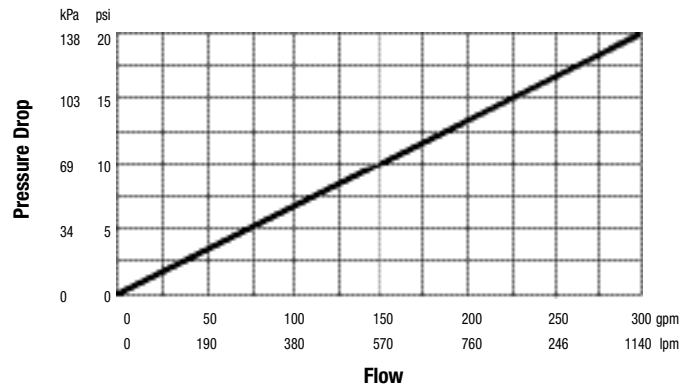

## Dimensions — Weights

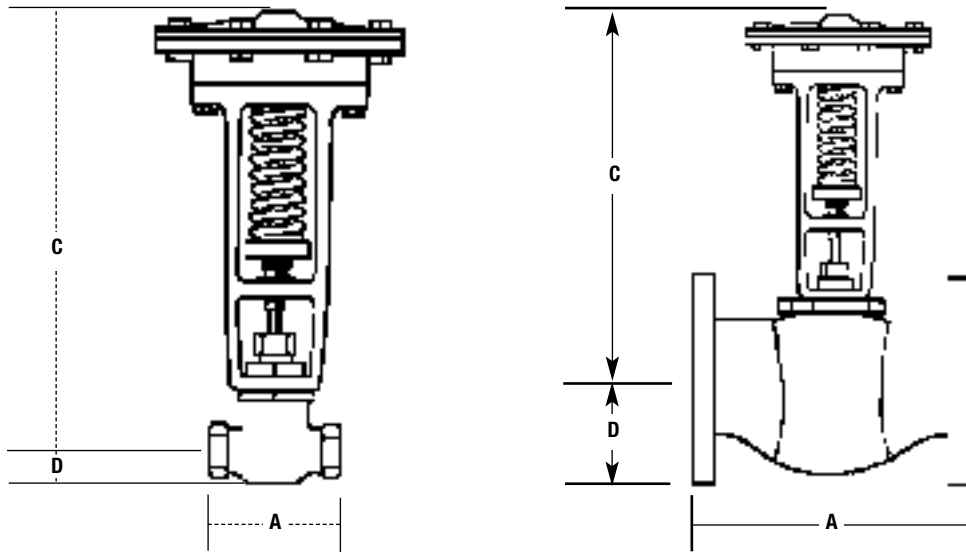

MODEL	SIZE (DN)		CONNECTION	DIMENSIONS (APPROX.)						WEIGHT	
	in.	mm		A		C		D		lbs.	kgs.
127W	3"	80	threaded	8	203	16 $\frac{1}{8}$	410	2 $\frac{3}{8}$	60	40	18
F127W	4"	100	flanged	12 $\frac{1}{8}$	308	16 $\frac{3}{4}$	425	4 $\frac{1}{2}$	114	84	38
F127W	3"	80	flanged	8	203	16 $\frac{3}{4}$	425	3 $\frac{3}{4}$	95	42	19

# Series 2300

## Direct Operated Water Pressure Reducing Valves

Sizes: 3" – 6" (80 – 150mm)

Series 2300 Direct Operated Water Pressure Reducing Valves are designed for dead-end water service where the flow is intermittent and changes rapidly, as on domestic water system. This Series is also installed to regulate the flow of water to such fast acting equipment as flushometers and snap cocks. The Series 2300 is recommended where city water pressure is to be reduced to supply plumbing fixtures to prevent violent pressure fluctuations.

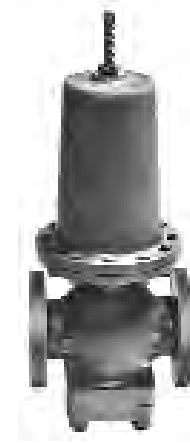

Series 2300

The design of this valve minimizes any danger of dirt lodging in the stem guide

Essentially balanced single seat minimizes a variation in delivery pressure resulting from a varying inlet pressure

No stem guide in bottom flange to collect dirt. These valves are self-aligning and the guiding of the disc is independent of the bolted bottom flange.

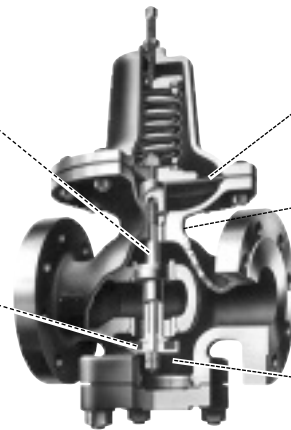

A large Hycar diaphragm ensures a sensitive response to the slightest change in reduced pressure

This design being self-contained, no control lines are required

Designed to close against the flow. Will not chatter or produce water hammer. Operates smoothly and quietly

### Features

- An essentially balanced single seat minimizes variation in delivery pressure resulting from varying inlet pressure
- A large Hycar diaphragm ensures a sensitive response to the slightest changes in reduced pressure
- Packless design eliminates stuffing box friction
- Hycar composition single seat provides for dead-end shutoff and prevents pressure-creep when no flow is required
- Self-aligning design. Eliminates the need for a stem guide in the bottom flanges and remove a point of direct collection that can cause faulty operation
- Disc and piston are located to minimize the possibility of obstruction by dirt
- Large pressure plate gives ample support to the diaphragm – assuring long life
- No stuffing boxes to stick
- Self contained design, requires no control lines
- All internal parts accessible by removing blind flange or spring chamber. Regular maintenance can be performed with the valve body in line
- No stuffing box maintenance required

### Pressure – Temperature

Maximum Temperature: 150°F (66°C)  
Maximum Pressure: 200psi (14 bar)  
Reduced Pressure Range: 30 – 80psi  
(207 – 552 kPa)

# Series 115 (Globe), 1115 (Angle) Water Pressure Reducing Automatic Control Valves

Sizes: 1¼" – 24" (32-600mm)

Series 115 (Globe) and 1115 (Angle) Water Pressure Reducing Automatic Control Valves automatically reduce a higher inlet pressure to a constant lower outlet pressure regardless of changing flow rates and or varying inlet pressure.

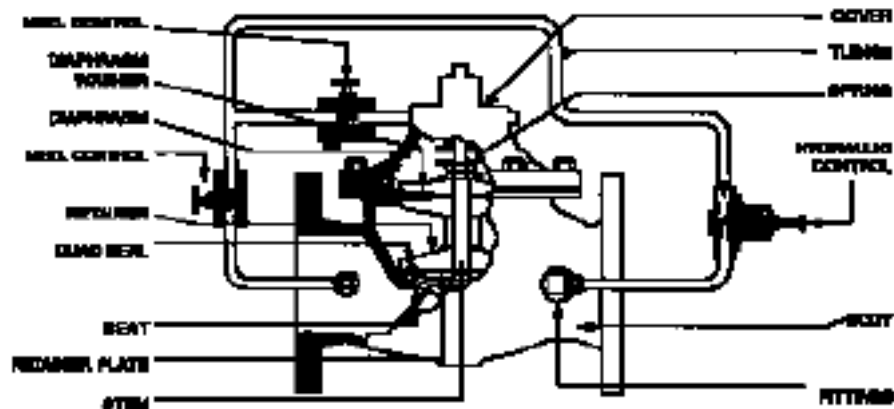
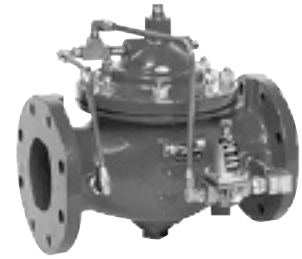

## Features

- Wide range of sizes available 1¼" – 24" (32 – 600mm)
- Fused epoxy coating 100% inside and out (FDA and NSF approved, meets AWWA standards)
- Exclusive "Quad Seal" provides positive drip-tight closure and longer valve lifespan
- Diaphragm actuated (one-moving part)
- Hydraulically operated (frictionless)
- Top and bottom guided stem
- Packless construction (less-maintenance)

## Models

- 115 (Globe)/1115 (Angle) – Pressure Reducing
- 115-2 (Globe)/1115-2 (Angle) – Pressure Reducing/Sustaining
- 115-3 (Globe)/1115-3 (Angle) – Pressure Reducing/Check
- 115-4 (Globe)/1115-4 (Angle) – Pressure Reducing/Solenoid On-Off
- 115-7 (Globe)/1115-7 (Angle) – Pressure Reducing/Surge
- 115-74 (Globe)/1115-74 (Angle) – Pressure Reducing/Low Flow Bypass Valve

## Standard Components

### 3" (80mm) and Smaller

- Flo-Clean pilot circuit strainer
- Adjustable opening speed control
- Fixed orifice supply restriction
- 20 – 175psi downstream adjustment range

### 4" and Larger

- Y-pattern pilot circuit strainer
- Pilot circuit isolation ball valves
- Fixed orifice supply restriction
- 20 – 175psi downstream adjustment range

## Optional Components

- Adjustable opening speed control 4" (100mm) and larger
- Pilot circuit isolation ball valves 3" (80mm) and smaller
- Y-Pattern pilot circuit strainer 3" (80mm) and smaller
- Adjustable closing speed control (all sizes)
- Position indicator (all sizes)
- Inlet and outlet pressure gauges (all sizes)

## Pressure-Temperature

- Adjustable Reduced Pressure Range: 20-175psi (1.3 – 12 bar)
- Optional Reduced Pressure Settings: 0-30psi (0 – 2 bar), 100-300psi (6.8 – 20 bar)

# Series N250, N250B

## Iron Body Water Pressure Reducing Valves with Integral Strainer

Sizes: 1/2" – 3/4" (15 – 20mm)

Series N250 and N250B iron body water pressure reducing valves are ideal for standard capacity domestic water pressure regulation service. These valves feature a special unitized construction which consists of the seat, disc and stem assembly plus strainer screen altogether in one unit for complete replacement maintenance.

### Features

- Stainless steel seat
- Stainless steel integral strainer
- High temperature resisting diaphragm for hot or cold water
- Special unitized construction
- All working parts easily and quickly

serviceable without removing valve from the line

- Optional bypass feature controls thermal expansion pressure

**Note:** Cast iron body regulators are not intended for buried or pit services.

**Note:** The bypass feature will not prevent the pressure relief valve from opening on the hot water supply system with pressures above 150psi.

For additional information, request literature ES-N250.



### Models

**N250** – NPT threaded female inlet and outlet connections

**N250B** – NPT threaded female inlet and outlet connections with thermal expansion bypass feature

# Series 26A, 263A and LF26A, LF263A

## Small Water Pressure Reducing Valves

Sizes: 1/8" – 1/2" (3 – 15mm)

Series 26A, 263A, LF26A, and LF263A small water pressure reducing valves are ideal for water and No. 2 fuel oil. The LF26A, LF263A features Lead Free\* construction to comply with Lead Free\* installation requirements. Applications include: beverage dispensers, ice cube machines, paint sprayers, humidifiers, etc. For other liquids contact your local Watts agent.

### Features

- Rugged forged brass body
- Lead Free\* models with Lead Free\* brass body construction
- Tee handle adjustment
- Oversized orifice

### Dimensions – Weights

MODEL	SIZE (DN)		DIMENSIONS (APPROX.)								WEIGHT	
	in.	mm	A		B		C		D		oz.	gm.
26A/LF26A	1/8	3	2 1/8	54	3 7/8	98	3	76	7/8	22	16	454
26A/LF26A	1/4	8	2 1/8	54	3 7/8	98	3	76	7/8	22	16	454
26A/LF26A	3/8	10	2 1/8	54	3 7/8	98	3	76	7/8	22	16	454
26A/LF26A	1/2	15	2 1/8	54	4	100	3 1/8	79	7/8	22	16	454
263A/LF263A	1/4	8	2 1/8	54	4 7/8	124	4	100	7/8	22	16	454
263A/LF263A	3/8	10	2 1/8	54	4 7/8	124	4	100	7/8	22	16	454
263A/LF263A	1/2	15	2 1/8	54	4	100	3 1/8	79	7/8	22	16	454

For additional information, request literature ES-26A/263A or ES-LF26A/263A.

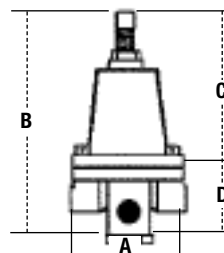

\*The wetted surface of this product contacted by consumable water contains less than one quarter of one percent (0.25%) of lead by weight.

# Series SS263AP\*

## Stainless Steel Water Pressure Reducing Valves

Sizes: 1/2" (15mm)

Series SS263AP stainless steel water pressure reducing valves are ideal for use with deionized water, chemical solutions, high purity, water purification systems and low pressure steam (15psi/103 kPa) applications.

### Features

- Rugged investment cast body and cage
- Oversized orifice
- Stainless steel adjusting screw
- Viton® Trim



\*This product complies with federal standards for lead content but contains greater than 0.25% lead, which exceeds limitations mandated by some states when used in drinking water systems.

# Series P60-M5\*

## Plastic Miniature Water Pressure Reducing Valves

Sizes: 1/4" (8mm)

Series P60-M5 plastic miniature water pressure reducing valves are ideal for applications where a small economical package is required. These valves are suitable for use with deionized water. The Series P60-M5 features a balanced piston design for applications where a constant downstream and accurate flow performance is required.

### Features

- Corrosion Resistant
- Compact design and lightweight construction
- All external components are made of an NSF approved grade acetal plastic
- All internal rubber components such as disc, diaphragm and seals are all FDA grade Buna-N
- Certified by NSF to NSF standard 61
- All internal metal components in contact with fluids are of Series 300 stainless steel
- Straight through or 90° inlet to outlet option
- High capacity
- Bottom clean out plug for service



For additional information, request literature ES-P60.

\*This product complies with federal standards for lead content but contains greater than 0.25% lead, which exceeds limitations mandated by some states when used in drinking water systems.

# Series 560, H560

## Water Pressure Reducing Valves

Sizes: 1/8" – 3/4" (3 – 20mm)

Series 560 and H560 water pressure reducing valves are ideal where a small economical package is required. The 560/H560 series is used on special industrial process applications, miscellaneous plumbing applications and OEM equipment.

### Features

- Rugged brass body, stainless steel stem and spring
- Oversized orifices, Buna-N seat and diaphragm
- Furnished standard with 1/8" (3mm) gauge port (plugged)
- Heavy duty adjusting screw. Adjusting screw is both slotted and knurled

For additional information, request literature ES-560/H560.

\*The wetted surface of this product contacted by consumable water contains less than one quarter of one percent (0.25%) of lead by weight.



# Series 123LP

## Water Pressure Reducing Valves

Sizes: 1/2" – 3/4" (15 – 20mm)

Series 123LP water pressure reducing valves feature high performance and flow capacity. These valves contains an integral stainless steel seat and strainer as well as bronze body construction. The Series 123LP is serviceable in-line as well.

### Features

- High performance
- High flow capacity
- Integral stainless steel valve seat
- Integral stainless steel strainer
- Bronze body construction
- Serviceable in-line



# Series 215

## Super Sensitive Low Pressure Water Pressure Regulators

Sizes: 1/4" – 3/8" (8 – 10mm)

Series 215 super sensitive low pressure water pressure regulators are especially designed to meet low pressure precision requirements. The high ratio of diaphragm to orifice provides excellent performance and stability at low reduced pressure. The Series 215's brass body and stainless steel internal parts make it ideally suited for water requirements up to 2.5gpm (9.5lpm). These valves are also suitable for pressure supply to wall attachment fluidic devices.

### Features

- Rugged forged brass body for water service
- Replaceable stainless steel seat
- Large diaphragm provides exceptional performance particularly under 10psi (.70 bar)
- 30 mesh stainless steel strainer

For additional information, request literature ES-215.

\*The wetted surface of this product contacted by consumable water contains less than one quarter of one percent (0.25%) of lead by weight.



# Model 276H300, IWTG

## Water Pressure Test Gauges

Model 276H300, IWTG water pressure test gauges are ideal to accurately determine system pressure in a building. The 1/4" hose connection easily attaches to a hose bibb or the drain connection on a water heater. A red indicator hand holds at the highest reading registered. When left on overnight, it will register the highest pressure in the system during that period.



### Models

<b>276H300</b>	0 – 300psi (0 – 20.7 bar)
<b>IWTG</b>	0 – 200psi (0 – 13.8 bar)

# Series DPG3, DPG5

## Water Pressure Gauges

Series DPG3, DPG5 Water Pressure Gauges fit all Watts valves with gauge option.

### Features

- ABS polymer case
- Kostil polymer window
- ASME Type “B” accuracy
- Copper alloy bourdon tube sensing element
- Tin alloy welding
- Working Temperature: -4°F – 176°F (-20°C – 80°C)

### Models

- DPG3** Center back entry pressure gauges
- DPG5** Top entry pressure gauges



**DPG3**



**DPG5**

### Dimensions

MODEL	SCALE		CONNECTION SIZE (DN)		DIAL SIZE	
			<i>in.</i>	<i>mm</i>	<i>in.</i>	<i>mm</i>
DPG3-1½	0 – 60psi	413 kPa	1/8	3	1½	38
DPG3-1½	0 – 160psi	11 bar	1/8	3	1½	38
DPG5-2	0 – 160psi	11 kPa	1/8	3	2	50

# Jumper Kits

## Temporary Bypass for Water Pressure Reducing Valves

Jumper kits are used in new construction as a temporary by-pass, prior to the actual installation of a water pressure reducing valve on potable water supply systems.

The use of a temporary jumper permits testing of the building piping system for leaks and pressure loss and facilitates pipe flushing prior to the installation of the water pressure reducing valve. On unsecured job sites, the jumper kit reduces loss from theft or vandalism.

They come complete with union connections, washers, and a brass or plastic pipe nipple with male union threads. The length of the jumper nipple matches the valve lay length, allowing the piping to be completed prior to the installation of a water pressure reducing valve and permitting quick change out from the jumper to the valve.

The jumper kits include a stainless steel strainer screen to provide protection from debris downstream of the valve.

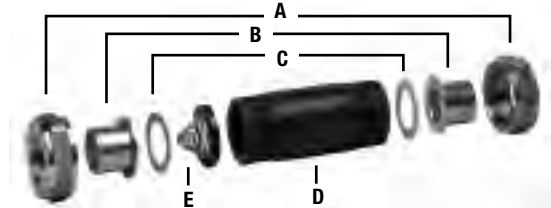

### Jumper Kit Exploded View

Kit Consists of:

- A – Union Nut (2)
- B – Sweat Tailpiece (2)
- C – Fiber Washer (2)
- D – Jumper Nipple
- E – Screen

### How to order jumper kits

Example: 3/4" JK P-345 S

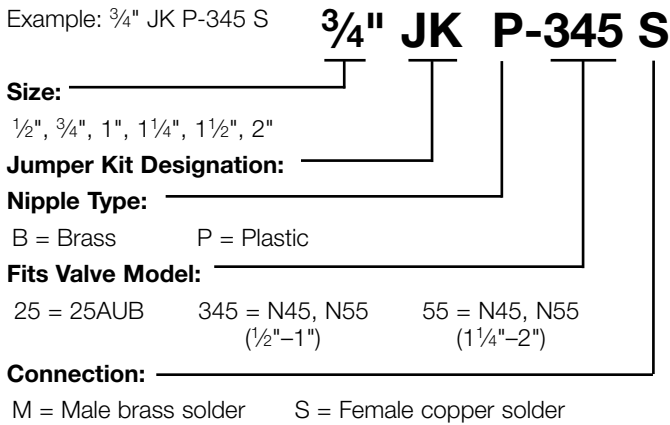

### JUMPER KITS COMPLETE KITS WITH PLASTIC NIPPLE

Model	Size
<b>Female x Female Copper Sweat Tailpiece</b>	
JK-P-25 S	3/4"
JK-P-345 S	3/4"
JK-P-25 S	1"
JK-P-345 S	1"
JK-P-25 S	1 1/4"
JK-P-55 S	1 1/4"
JK-P-25 S	1 1/2"
JK-P-55 S	1 1/2"
JK-P-25 S	2"
JK-P-55 S	2"
<b>Female Copper Sweat x Male Brass Sweat Tailpiece</b>	
JK-P-345-FM S	3/4"
JK-P-345-FM S	1"
<b>Male x Male Brass Sweat Tailpiece</b>	
JK-P-345-MM S	1"

### COMPLETE KITS WITH BRASS NIPPLE

Model	Size
<b>Female x Female Copper Sweat Tailpiece</b>	
JK-B-25 S	3/4"
JK-B-345 S	3/4"
JK-B-25 S	1"
JK-B-345 S	1"
JK-B-25 S	1 1/4"
JK-B-55 S	1 1/4"
JK-B-25 S	1 1/2"
JK-B-55 S	1 1/2"
JK-B-25 S	2"
JK-B-55 S	2"

Jumper Kits Include: Jumper Nipple, strainer screen, 2 fiber washers, 2 union nuts and tailpieces as described above.

When removing Jumper Nipple and inserting the water pressure reducing valve, two O-rings (ordered separately) are required. Refer to literature PL-RP-GP for O-ring ordering information.

# For Technical Assistance Call Your Authorized Watts Representative.

			Telephone	E-mail
	<b>HEADQUARTERS:</b> Watts Regulator Company	815 Chestnut St., North Andover, MA 01845-6098 U.S.A.	978 688-1811	watts@wattswater.com
North East	Edwards, Platt & Deely, Inc.	277 Royal Ave., Hawthorne, NJ 07506	973 427-2898	p044@watts.com
	Edwards, Platt & Deely, Inc.	368 Wyandanch Ave., North Babylon, NY 11703	631 253-0600	p073@watts.com
	Vernon Bitzer Associates, Inc.	980 Thomas Drive, Warmingster, PA 18974	215 443-7500	P009@watts.com
	W. P. Haney Company, Inc.	51 Norfolk Ave., South Easton, MA 02375	508 238-2030	p088@watts.com
Mid Atlantic	Disney McLane & Associates	428 McGregor Ave., Cincinnati, OH 45206	800 542-1682	p017@watts.com
	J. B. O'Connor Company, Inc.	P.O. Box 12927, Pittsburgh, PA 15241	724 745-5300	p047@watts.com
	RMI	Glenfield Bus. Ctr., 2533 Mechanicsville Tpk., Richmond, VA 23223	804 643-7355	rmi@ricmrk.com
	The Joyce Agency, Inc.	8442 Alban Rd., Springfield, VA 22150	703 866-3111	p069@watts.com
	WMS Sales, Inc. (Main office)	9580 County Rd., Clarence Center, NY 14032	716 741-9575	p091@watts.com
South East	Billingsley & Associates, Inc.	2728 Crestview Ave., Kenner, LA 70062-4829	504 602-8100	p013@watts.com
	Billingsley & Associates, Inc.	478 Cheyenne Lane, Madison, MS 39110	601 856-7565	chkenny@billingsley.com
	Francisco J. Ortiz & Co., Inc.	Charlyn Industrial Pk., Road 190 KM1.9 - Lot #8, Carolina, Puerto Rico 00983	787 769-0085	p029@watts.com
	Mid-America Marketing, Inc.	203 Industrial Drive, Birmingham, AL 35211	205 879-3469	p032@watts.com
	Mid-America Marketing, Inc.	1364 Foster Avenue, Nashville, TN 37210	615 259-9944	john@midamericamktg.com
	Mid-America Marketing, Inc.	5466 Old Hwy. 78, Memphis, TN 38118	901 795-0045	sales@midamericamktg.com
	Smith & Stevenson Co., Inc.	4935 Chastain Ave., Charlotte, NC 28217	704 525-3388	p003@watts.com
	Harry Warren, Inc.	1400 North Orange Blossom Trail, Orlando, FL 32804	407 841-9237	p071@watts.com
	Watts Georgia	2861-B Bankers Industrial Drive, Atlanta, GA 30360	770 209-3310	p059@watts.com
North Central	Dave Watson Associates	1325 West Beecher, Adrian, MI 49221	517 263-8988	p085@watts.com
	Mid-Continent Marketing Services Ltd.	1275 Lakeside Drive, Romeoville, IL 60446	630 953-1211	p072@watts.com
	Soderholm & Associates, Inc.	7150 143rd Ave. N.W., Anoka, MN 55303	763 427-9635	company@soderholmrep.com
	Stickler & Associates	203 S. Curtis Road, Milwaukee, WI 53214	414 771-0400	sales@sticklerassociates.com
South Central	Hugh M. Cunningham, Inc.	13755 Benchmark, Dallas, TX 75234	972 888-3808	p031@watts.com
	Sandia Group, Inc.	3167 San Mateo #308, Albuquerque, NM 87110	800 339-0191	p031@watts.com
	Mack McClain & Associates, Inc.	4407 Meramec Bottom, Suite G, St. Louis, MO 63129	314 894-8188	p045@watts.com
	Mack McClain & Associates, Inc.	1450 NE 69th Place, Ste. 56 Ankeny, IA 50021	515 288-0184	p049@watts.com
	Mack McClain & Associates, Inc.	15090 West 116th St., Olathe, KS 66062	913 339-6677	p083@watts.com
	OK! Sales, Inc.	214 NE 12th. St., Ste A, Moore, OK 73160	405 794-5200	oksales@coxinet.net
Western	Delco Sales, Inc.	1930 Raymer Ave., Fullerton, CA 92833	714 888-2444	sales@delcosales.com
	Delco Sales, Inc.	111 Sand Island Access Rd., Unit I-4, Honolulu, HI 96819	808 842-7900	p021@watts.com
	Fanning & Associates, Inc.	6765 Franklin St., Denver, CO 80229-7111	303 289-4191	sales@fanningandassociates.com
	Hollabaugh Brothers & Associates	6915 South 194th St., Kent, WA 98032	253 867-5040	p001@watts.com
	Hollabaugh Brothers & Associates	3028 S.E. 17th Ave., Portland, OR 97202	503 238-0313	p006@watts.com
	P I R Sales, Inc.	3050 North San Marcos Place, Chandler, AZ 85225	480 892-6000	sales@pirsales.com
	Preferred Sales	30852 Huntwood Ave., Hayward, CA 94544	510 487-9755	p094@watts.com
	R. E. Fitzpatrick Sales, Inc.	4109 West Nike Dr. (8250 South), West Jordan, UT 84088	801 282-0700	p007@watts.com
Canada	Watts Water Technologies (Canada) Inc.	5435 North Service Road, Burlington, Ontario L7L 5H7	905 332-4090	info@wattscanada.ca
	Con-Cur West Marketing, Inc.	71B Clipper Street, Coquitlam, British Columbia V3K 6X2	604 540-5088	dconte@concurwest.com
	D.C. Sales Ltd.	#13-6130 4th St. S.E., Calgary, Alberta T2H 2B6	403 253-6808	barry.graham@dcsalesltd.com
	D.C. Sales Ltd.	16726 111 Ave, Edmonton, Alberta T5M 2S6	780 496-9495	barry.graham@dcsalesltd.com
	GTA Sales Team.	Greater Toronto Area	888 208-8927	gtasales@wattscanada.ca
	Hydro-Mechanical Sales, Ltd.	3700 Joseph Howe Drive, Suite 1, Halifax, Nova Scotia B3L 4H7	902 443-2274	jeff@hydromechanical.ca
	Hydro-Mechanical Sales, Ltd.	P.O. Box 1445 (Mailing), 297 Collishaw St., Suite 7 (shipping) Moncton, New Brunswick E1C 9R2	506 859-1107	mark@hyromechanical.ca
	J.D.S. Sales Ltd.	4 Lancaster Street, St. John's, Newfoundland A1A 5P7	709 579-5771	jds@nf.sympatico.ca
	Les Ent. Roland Lajoie	6221 Marivaux, St-Leonard, QC H1P 3H6	514 328-6645	info@ent-lajoie.com
	Les Ent. Roland Lajoie	23 du Buisson, Pont Rouge, QC G3H 1X9	418 873-2500	strudel@ent-lajoie.com
	Mar-Win Agencies, Ltd.	1333 Clifton St., Winnipeg, Manitoba R3E 2V1	204 775-8194	marwin@mts.net
	Northern Mechanical Sales	P.O. Box 280 (mailing) 163 Pine St. (shipping), Garson, Ontario P3L 1S6	705 693-2715	normec@sympatico.ca
	Palser Enterprises, Ltd.	P.O. Box 28136 (mailing), 1885 Blue Heron Dr., #4, London, Ontario N6H 5L9	519 471-9382	sales@palserent.com
RAM Mechanical Marketing Inc.	905 Winnipeg Street, Regina, Saskatchewan S4R 1J1	306 525-1986	ram@accesscomm.ca	
RAM Mechanical Marketing Inc.	510 Ave M South, Saskatoon, Saskatchewan S7M 2K9	306 244-6622	info@rammarketing.ca	
Walmart Mechanical Sales	24 Gurdwara Rd., Nepean, Ontario K2E 8B5	613 225-9774	christisbrown@walmart.net	
1012	<b>EXPORT Hdqtrs.:</b> Watts Regulator Co.	815 Chestnut St., North Andover, MA 01845-6098 U.S.A.	978 688-1811	watts@wattswater.com



A Watts Water Technologies Company



USA: No. Andover, MA • Tel. (978) 688-1811 • Fax: (978) 794-1848 • www.watts.com

Canada: Burlington, ONT. • Tel. (905) 332-4090 • Fax: (905) 332-7068 • www.wattscanada.ca